



WORM REDUCERS RATINGS & SELECTION



EXPLANATION AND USE OF RATINGS AND SERVICE FACTORS

Gear unit selection is made by comparing actual transmitted loads with catalogue ratings. However, it is important to realise that catalogue ratings are based on a standard set of loading conditions, which inevitably change for different applications. Therefore, a service factor must be used to calculate a theoretical transmitted load, or equivalent load, before comparing with catalogue ratings.

Equivalent load = actual load x service factor.

Mechanical Ratings and Service Factors

Mechanical ratings measure capacity in terms of life and/or strength, assuming 10 hours per day continuous running under uniform load conditions, when lubricated with an approved oil and working at a maximum oil temperature of 100°C. For normal application lubricant equivalent to **ISO VG 320** should be used. See publication G/105 for details.

When a unit transmits less than catalogue rating its life is increased, if the running time is more than 10 hours per day, a service factor from Table 1 ensures selection of a unit which transmits less than catalogue rating, its life therefore is increased consistent with the increased daily running time. If this increased life is not required, the service factor need not be used. Similarly the use of a service factor for less than 10 hours per day gives a reduced life consistent with the reduced daily running time.

Catalogue ratings allow 100% overload at starting, braking or momentarily during operation, up to 10 times per day. The unit selected must therefore have a catalogue rating equal to, or greater than half the maximum overload.

If the unit is subjected to sustained overloads or to shock loads, these must be reflected in the chosen service factor if overloads can be calculated or estimated then the actual loads should be used instead of a factor. When detailed operating conditions are not available Table 3, page 4 gives a guide to the load characteristics of many varied applications, and should be used to determine appropriate service factors from table 1.

Thermal Ratings and Service Factors

Thermal ratings measure the unit's ability to dissipate heat, if they are exceeded the lubricant may overheat and break down, with consequent life failure.

Both mechanical and thermal ratings are given for unit sizes 1000 and above, lower rating deciding the unit's capacity. For other units mechanical ratings are over-riding and thermal ratings are not relevant.

Thermal ratings are affected by ambient temperature and not by mechanical considerations such as increased running time or shock loads. Catalogue ratings assume 20°C ambient temperature, the oil (or grease) temperature then rising as the units transmit power and generate heat.

If the ambient temperature is more than 20°C, a lower temperature rise is allowed therefore less power may be transmitted. Similarly in cooler temperatures the thermal ratings may be exceeded. When selecting units use a service factor from Table 2 to calculate equivalent loads.

For unit sizes 112 to 800, the relevant mechanical and thermal service factors are selected from tables and whichever is higher is applied to find out the equivalent output power and output torque. For unit sizes 1000 to 1700, mechanical service factor should be applied to mechanical ratings and thermal service factor to thermal ratings. Higher of these should be considered for selection of the unit.

Thermal ratings assume fan cooling which is a standard feature of worm gear units.

For intermittent running with ample cooling time during rest periods, thermal ratings may be exceeded without overheating, and since the fan is ineffective it can usually be removed.

Adaptable Gear Units



Solid Foot Gear Units



Heavy Duty Gear Units





Table 1. Mechanical Service Factors

Prime Mover	Duration of Service - hrs per day	Load classification-driven machine		
		Uniform Shock	Moderate Shock	Heavy Shock
Electric motor, steam turbine or hydraulic motor	Under 3	0.80	1.00	1.50
	3 to 10	1.00	1.25	1.75
	Over 10	1.25	1.50	2.00
Multi-cylinder internal combustion engine	Under 3	1.00	1.25	1.75
	3 to 10	1.25	1.50	2.00
	Over 10	1.50	1.75	2.25
Single cylinder internal combustion engine	Under 3	1.25	1.50	2.00
	3 to 10	1.50	1.75	2.25
	Over 10	1.75	2.00	2.50

Table 2. Thermal Service Factors

Ambient temp. °C	Running Time in any Hour				
	100%	80%	60%	40%	20%
10	0.87	0.73	0.62	0.54	0.48
20	1.00	0.84	0.71	0.62	0.56
30	1.16	0.97	0.82	0.72	0.64
40	1.35	1.13	0.96	0.84	0.75
50	1.62	1.35	1.16	1.00	0.90

For applications where high inertia loads are to be absorbed. e.g. crane travel drives, slewing motions, etc. unit selection should be made by Premium engineers.

When selecting units use the actual load transmitted and not the rating of the prime mover, and wherever possible use output torque (Nm). Catalogues also give input power (KW), being the power which the prime mover must provide to allow for losses in the gear unit. When units transmit less than rated output torque the input power is reduced, and although a gear unit is marginally less efficient at part load a, pro-rata reduction is usually sufficiently accurate to decide the capacity of the prime mover.

Examples

Example (Sizes 112 to 800)

A Premium speed reducer, with the worm under the wheel, is required for a conveyor handling non-uniform material and which is operating 8 hours/day. The motor speed is 1000 rpm and power required at the output shaft is 4 KW at 29 rpm, Ambient temperature is 50°C or less.

$$\text{Ratio required} = \frac{1000}{29} = 34,48/1 \quad (\text{35/1 approx.})$$

From table 3, page 4, load on the unit is moderate shock. Hence mechanical service factor is 1.25 from table 1 page 3, But thermal service factor corresponding to 50°C ambient temperature is 1,62 from table 2, page 3. Therefore the higher of the two i.e. 1.62 is selected as service factor.

$$\begin{aligned} \text{Equivalent output power} &= 4 \times 1.62 \\ &= 6.48 \text{ KW} \\ \text{Equivalent output torque} &= 6.48 \times 9550/29 \\ &= 2134 \text{ Nm} \end{aligned}$$

Adaptable Gear Units

From rating table on page 7, U700 unit with allowable torque 2960 Nm is selected.

$$\begin{aligned} \text{Required input power} &= \\ 2134 \times 11.0 &= 4.895 \text{ KW} \\ 2960 \times 1.62 & \end{aligned}$$

Nearest standard motor is 5.5 KW

Example (Sizes 1000 to 1700)

A Premium speed reducer is required to drive a bucket elevator which is not uniformly loaded and operates for 10 hours a day, transmitting 38 KW at 31 rpm and driven by motor.

The ambient temperature is 40°C or less.

$$\begin{aligned} \text{Unit Ratio} &= 1500/31 = 48.4/1 \\ & \quad (50/1 \text{ approx.}) \end{aligned}$$

From table 3 on page 4, the load is moderate shock load. Hence the mechanical service factor is 1.25

$$\begin{aligned} \text{Equivalent output power (mechanical)} & \\ &= 38 \times 1.25 = 47.5 \text{ KW} \end{aligned}$$

$$\begin{aligned} \text{Equivalent output torque (mechanical)} & \\ &= 47.5 \times 9550/31 = 14633 \text{ Nm} \end{aligned}$$

Hence unit size 1400 which gives 15000 Nm output torque with 57.9 KW input power may be suitable.

Thermal service factor from table 2 is 1.35 for an ambient temperature of 40°C.

$$\begin{aligned} \text{Equivalent output power (thermal)} & \\ &= 38 \times 1.35 = 51.3 \text{ KW} \end{aligned}$$

$$\begin{aligned} \text{Equivalent output torque (thermal)} & \\ &= \frac{51.3 \times 9550}{31} = 15804 \text{ Nm} \end{aligned}$$

Since the thermal output torque rating of 1400 unit is only 10700 Nm, which is less than 15804 Nm, 1700 unit size is selected. Mechanical output torque rating of 1700 unit is 29100 Nm and mechanical input power is 109 KW,

$$\begin{aligned} \text{Required input power} & \\ 14633 \times 109 & \\ 29100 \times 1.25 & = 43.849 \text{ KW} \end{aligned}$$

Nearest standard motor is 45 KW

Enquiries

It is recommended that as much as possible of the following Information be given in the enquiry or order so that a check can be made and advice given on the most suitable size of gear box for any application.

1. Type of prime mover.
2. Horse-power of prime mover.
3. Output torque required from driven member.
4. Input speed of gear unit.
5. Output speed of gear unit.
6. Configuration of drive required and shaft disposition.
7. Total daily hours of running. If running is Intermittent, details of duty cycle should be given. Particulars of any abnormal starting load should be stated.
8. Details of reversing or shock loads.
9. Details of any external loads imposed on gear unit.
10. Details of any abnormal operating conditions, e.g. ambient temperature, humidity, etc.

Nominal ratios are shown in the rating table for convenience, Details of exact standard ratios are given on page 9.

Where external overhung loads are to be supported by the gear unit, a check must be made using data given on page 10 to ensure that these loads are within the capacity of the unit.



Load Classification by applications

U = Uniform load

H = Heavy shock load

* 24 hours/day Service Factor Only

‡ Use 1.25 Service Factor

M = Moderate shock load

† = Refer to Greaves

** Use 1.00 Service Factor

‡‡ Use 1.50 Service Factor

Driven machine	Type of load	Driven machine	Type of load	Driven machine	Type of load
Agitators		assembly	M	belt	M
Agitators		belt		disc	
pure liquids	U	M		U	
liquids and solids	M	bucket	M	reciprocating	H
liquids-variable density	M	chain	M	screw	M
Blowers		flight		Food industry	
centrifugal	U	M		beef slicer	M
lobe		live roll	†	cereal cooker	U
M		oven		dough mixer	M
vane		M		meat grinders	M
U		reciprocating	H	Generators-not welding	U
Brewing and distilling		shaker	H	Hammer mills	H
bottling machinery	U	Cranes		Hoists	
brew kettles-continuous duty		main hoists	U	heavy duty	H
U		bridge travel	†	medium duty	M
cookers-continuous duty	U	trolley travel	†	skip hoist	M
mash tubs-continuous duty	U	Crusher		Laundry washers	
scale hooper-frequent starts	M	ore		reversing	M
Can filling machines	U	H		Laundry lumbers	M
Cane knives	M	stone	H	Line shafts	
Car dumpers	H	sugar	M	driving processing equipment	M
Car pullers	M	Dredges		light	
Clarifiers	U	cable reels	M	U	
Classifiers	M	conveyors	M	other line shafts	U
Clay working machinery		cutter head drives	H	Lumber Industry	
brick press	H	jig drives	H	barkers-hydraulic	
briquette machine	H	manoeuvring winches	M	mechanical	M
clay working machinery	M	pumps	M	burner conveyor	M
pug mill	M	screen drive	H	chain sow and drag sow	H
Compressors		stackers	M	Chain transfer	H
centrifugal	U	utility winches	M	craneway transfer	H
lobe		Duty dock crow		de-barking drum	H
M		main hoist	**	edger feed	M
reciprocating		auxiliary hoist	**	gang feed	M
multi-cylinder		boom, luffing		green chain	M
single-cylinder		rotating, swing or slew	‡	live rolls	H
Conveyors uniformly		tracking, drive wheels	‡‡	log deck	H
loaded or fed		Elevators		log haul-Incline	H
apron	U	bucket-uniform load	U	log haul-well type	H
assembly	U	bucket-heavy load	M	log turning device	H
belt		bucket-continuous	U	main log conveyor	H
U		centrifugal discharge escalators	U	off bearing rolls	M
bucket	U	freight	M	planer feed chains	M
chain	U	gravity discharge	U	planer floor chains	M
flight		man lifts	†	planer tilting hoist	M
U		passenger	†	re-saw merry-go-round	
oven		Fans		conveyor	M
U		centrifugal	U	roll cases	H
Screw		cooling towers		slab conveyor	H
Conveyors-heavy duly		Induced draft	†	small waste conveyor-belt	U
not uniformly fed		forced draft	†	small waste conveyor-chain	M
apron	M	Induced draft	M	sorting table	M
		large, mine. etc.	M	tipple hoist conveyor	M
		large, Industrial	M	tipple hoist drive	M
		light, small diameter	U	transfer conveyors	M
		Feeders		transfer rolls	M
		apron	M		



Load Classification by applications

Driven machine	Type of load	Driven machine	Type of load	Driven machine	Type of load
tray drive	M	converting machine		collectors	U
trimmer feed	M	except cutters, platers	M	dewatering screws	M
waste conveyor	M	conveyors	U	scum breakers	M
Machine tools		couch	M	slow or rapid mixers	M
bending roll	M	cutters-plates	H	thickeners	M
punch press-gear driven	H	cylinders	M	vacuum filters	M
notching press-belt driven	-	dryers	M	Screens	
plate planers	H	felt stretcher	M	air washing	U
topping machine	H	felt whipper	H	rotary-stone or gravel	M
other machine tools		jordans	M	travelling water intake	U
main drives		log haul	H	Slab pushers	M
auxillary drives		presses	M	Steering gear	†
Metal mills		pulp machine reel	M	Stokers	
draw bench carriage		stock chest	M	U	
and main drive	M	suction roll	M	Sugar Industry	
pinch, dryer and scrubber		washers and thickeners	M	cone knives	M
rolls reversing	†	winders	M	Crushers	
slitters	M	Printing presses	†	mills*	
table conveyors		Pullers		M	
non-reversing		barge haul	H	Textile Industry	
group drives	M	Pumps		batches	M
Individual drives	H	centrifugal	U	calenders	M
reversing	†	proportioning	M	cards	M
wire drawing and		reciprocating		dry cans	M
flattening machine	M	single acting 3 or		dryers	M
wire winding machine	M	more cylinders	M	dyeing machinery	M
Mills-rotary type		double acting 2 or		knitting machines	†
ball*		more cylinders	M	looms	M
M		single acting 1 or 2		mangles	M
cement kilns*	M	cylinders	†	nappers	M
dryers and coolers*	M	double acting single		pads	
kilns, other than cement	M	cylinder	†	M	
pebble*		rotary		range drives	-
rod*		gear type	U	slashers	M
plain	M	lobe,vane	U	soapers	M
wedge bar	M	Rubber and plastics		spinners	M
tumbling barrels	H	Industries		tenfer frames	M
Mixers		crackers*	H	washers	M
concrete mixers continuous	M	laboratory equipment	M	winders	M
concrete mixers-intermittent	M	mixed mills*	H	Windlass	†
constant density	U	refiners*	M		
variable density	M	rubber calenders*	M		
Oil Industry		rubber mill 2 on line*	M		
chillers	M	rubber mill 3 on line*	U		
oil well pumping	†	sheeter*	M		
paraffin filter press	M	fire building machines	†		
rotary kilns	M	fire and tube press			
Paper mills		openers	†		
agitators, (mixers)	M	tubers and strainers*	M		
barker-auxiliaries-hydraulic	M	worming mills*	M		
barker-mechanical	H	Sand muller	M		
barker drum	H	Sewage disposal			
beater and pulper	M	equipment			
bleacher	U	bar screens	U		
calenders	M	chemical feeders	U		
calenders-super	H				



Ratings at 1500 RPM Input Speed

Nominal Ratio RPM	Nominal Output	Capacity	Unit Size					
			112	162	200	237	287	337
5/1	300	Input Power KW	0.548	1.243	2.72	4.05	5.51	10.8
		Output Torque Nm	16.6	38.4	77.5	121	171	312
7.5/1	200	Input Power KW	-	1.081	1.93	2.92	4.76	7.24
		Output Torque Nm	-	45.8	82.6	126	203	311
10/1	150	Input Power KW	0.432	1.052	1.88	2.60	3.82	6.29
		Output Torque Nm	24.6	61.8	112	146	228	354
15/1	100	Input Power KW	0.329	0.942	1.50	2.30	3.71	5.62
		Output Torque Nm	25.0	73.5	120	186	301	462
20/1	75	Input Power KW	0.300	0.655	1.40	2.30	3.71	5.62
		Output Torque Nm	28.3	67.1	142	233	294	447
25/1	60	Input Power KW	0.266	0.578	1.14	1.83	2.74	3.91
		Output Torque Nm	30.2	70.8	142	231	352	511
30/1	50	Input Power KW	0.217	0.515	0.94	1.46	2.31	3.50
		Output Torque Nm	28.5	73.0	137	214	348	537
40/1	37.5	Input Power KW	0.164	0.427	0.70	1.06	1.68	2.55
		Output Torque Nm	25.4	76.1	129	197	321	498
50/1	30	Input Power KW	0.112	0.309	0.53	0.820	1.31	1.91
		Output Torque Nm	20.9	65.0	115	180	301	446
60/1	25	Input Power KW	0.096	0.240	0.38	0.60	1.00	1.55
		Output Torque Nm	14.8	43.5	75.2	121	264	412
70/1	21.4	Input Power KW	0.090	0.206	0.35	0.53	1.81	1.18
		Output Torque Nm	14.6	43.7	74.0	118	198	305

Nominal Ratio RPM	Nominal Output	Capacity	Unit Size				
			400	500	600	700	800
5/1	300	Input Power KW	12.8	20.9	38.4	51.5	70.4
		Output Torque Nm	372	629	1130	1560	2140
7.5/1	200	Input Power KW	9.18	17.5	26.3	41.5	54.4
		Output Torque Nm	405	769	1190	1860	2450
10/1	150	Input Power KW	8.36	15.9	23.1	31.9	41.3
		Output Torque Nm	467	914	1330	1840	2390
12.5/1	120	Input Power KW	7.25	-	-	-	-
		Output Torque Nm	530	-	-	-	-
15/1	100	Input Power KW	6.67	11.3	20.0	27.6	37.1
		Output Torque Nm	541	927	1700	2360	3190
20/1	75	Input Power KW	5.81	10.4	15.9	21.5	29.4
		Output Torque Nm	618	1130	1800	2370	3280
25/1	60	Input Power KW	4.76	8.00	12.5	19.7	26.9
		Output Torque Nm	616	1060	1680	2680	3710
30/1	50	Input Power KW	4.25	7.45	11.8	16.2	21.6
		Output Torque Nm	641	1160	1880	2610	3500
35/1	42.9	Input Power KW	-	6.71	10.3	14.2	-
		Output Torque Nm	-	1190	1880	2580	-
40/1	37.5	Input Power KW	3.50	5.72	9.64	13.7	17.9
		Output Torque Nm	673	1110	1960	2830	3740
50/1	30	Input Power KW	2.68	4.74	7.81	11.9	15.7
		Output Torque Nm	603	1110	1900	2980	3950
60/1	25	Input Power KW	2.29	4.16	6.24	9.4	13.2
		Output Torque Nm	593	1140	1750	2720	3870
70/1	21.4	Input Power KW	1.98	3.40	5.35	7.75	10.9
		Output Torque Nm	577	1030	1670	2490	3540

Ratings at 1500 RPM Input Speed

Nominal Ratio	Nominal Output RPM	U & V TYPE UNIT SIZE				O TYPE UNIT SIZE		
		1000	1200	1400	1700	1000	1200	1400
Input Power	- Mechanical	KW	KW	KW	KW	KW	KW	KW
Output Torque	- Mechanical	Nm	Nm	Nm	Nm	Nm	Nm	Nm
Input Power	- Thermal	KW	KW	KW	KW	KW	KW	KW
Output Torque	- Thermal	Nm	Nm	Nm	Nm	Nm	Nm	Nm
5/1	300	121	180	249	-	121	180	249
		3690	5470	7460	-	3690	5470	7460
		88.2	124	Forced	-	88.2	122	Forced
		2680	3790	Lubrication	-	2680	3720	Lubrication
7.5/1	200	89	138	186	-	89	138	186
		4030	6220	8420	-	4030	6220	8420
		74.8	108	155	-	74.8	106	131
		3380	4900	7030	-	3380	4790	5990
10/1	150	62.3	113	152	318	62.3	113	152
		3630	6630	8940	19200	3630	6630	8940
		67.3	97.8	146	193	67.3	94.6	123
		3920	5750	8590	11600	3920	5600	7290
12.5/1	120	-	90.6	141	-	-	90.6	141
		-	6760	10700	-	-	6760	10700
		-	90.7	125	-	-	87.3	98
		-	6770	9490	-	-	6570	7490
15/1	100	55.5	79.4	146	242	55.5	79.6	146
		4800	6900	12800	21200	4800	6900	12800
		54.1	81.1	115	164	52.3	72.5	87.6
		4680	7040	10100	14300	4550	6350	7710
20/1	75	52.8	82.5	118	206	52.8	82.5	118
		6050	9490	13600	23700	6050	9490	13600
		45.5	67	100	131	40.8	55.1	72.3
		5190	7690	11500	15000	4700	6390	8400
25/1	60	43.5	65.9	93.1	152	43.5	65	93.4
		6070	9290	13100	21600	6070	9290	13100
		36.4	54.4	79.5	104	30.9	42.7	56.4
		5060	7760	11200	14600	4340	6170	8010
30/1	50	36.9	59.3	84.4	148	36.9	59.3	84.4
		6080	9890	14600	24700	6080	9890	14600
		31.6	49	69.3	96.6	26.1	36.8	47.2
		5180	8140	11900	16000	4330	6200	8230
35/1	42.9	-	47.1	-	-	-	47.1	-
		-	9250	-	-	-	9250	-
		-	42.8	-	-	-	30.6	-
		-	8390	-	-	-	6100	-
40/1	37.5	31.8	49.9	70	100	31.8	49.9	70
		6830	10900	15200	22000	6830	10900	15200
		24.6	3702	50	74.4	18.5	25.7	31.7
		5250	8060	10700	16200	4010	5660	6990
50/1	30	26.6	40.4	57.9	109	26.6	40.4	57
		6880	10600	15000	29100	6880	10600	15000
		20.9	31	41	64.5	14.5	19.6	24.1
		5350	8100	10700	16800	3770	5220	6420
60/1	25	22.5	34.4	52.6	69.6	22.5	34.4	52.6
		6750	10400	16300	27900	6450	10400	16300
		18.1	26	38.4	49.3	11.5	15	20.7
		5390	7740	11900	17200	3480	4560	6470
70/1	21.4	18.5	29.7	43.8	74.2	18.5	29.7	43.8
		6340	10400	15200	26200	6340	10400	15200
		17.2	25.4	32.4	47.3	9.92	13.2	15.5
		5850	8790	11100	16200	3440	4700	5450



Ratings at 1000 RPM Input Speed

Nominal Ratio RPM	Nominal Output	Capacity	Unit Size					
			112	162	200	237	287	337
5/1	200	Input Power KW	0.432	0.986	2.16	3.21	4.23	8.62
		Output Torque Nm	19.4	44.9	90.9	142	195	369
7.5/1	133.3	Input Power KW	-	0.846	1.52	2.30	3.75	5.73
		Output Torque Nm	-	53.1	95.9	147	237	364
10/1	100	Input Power KW	0.338	0.824	1.47	2.04	3.00	4.94
		Output Torque Nm	28.4	71.2	129	169	264	411
15/1	66.7	Input Power KW	0.257	0.736	1.16	1.74	2.91	4.41
		Output Torque Nm	28.5	84.2	137	213	346	532
20/1	50	Input Power KW	0.238	0.508	1.10	1.74	2.16	3.26
		Output Torque Nm	32.2	76.4	163	266	336	513
25/1	40	Input Power KW	0.210	0.506	0.90	1.45	2.17	3.10
		Output Torque Nm	34.3	89.0	161	263	403	585
30/1	33.3	Input Power KW	0.173	0.458	0.74	1.16	1.82	2.76
		Output Torque Nm	32.2	93.0	155	244	397	612
40/1	25	Input Power KW	0.126	0.338	0.56	0.84	1.33	2.02
		Output Torque Nm	27.7	85.9	146	223	364	566
50/1	20	Input Power KW	0.088	0.228	0.410	0.65	1.03	1.52
		Output Torque Nm	18.3	68.4	125	204	340	505
60/1	16.7	Input Power KW	0.074	0.190	0.296	0.450	0.750	1.14
		Output Torque Nm	16.8	49.4	84.8	130	278	433
70/1	16.7	Input Power KW	0.067	0.162	0.257	0.420	0.610	0.960
		Output Torque Nm	16.3	47.9	82.5	136	225	346

Nominal Ratio RPM	Nominal Output	Capacity	Unit Size				
			400	500	600	700	800
5/1	200	Input Power KW	10.3	16.8	29.8	41.6	56.8
		Output Torque Nm	446	754	1310	1880	2580
7.5/1	133.3	Input Power KW	7.30	14.0	20.8	33.0	43.3
		Output Torque Nm	479	912	1410	2210	2920
10/1	100	Input Power KW	6.61	12.6	18.2	25.2	32.6
		Output Torque Nm	550	1080	1560	2180	2820
12.5/1	80	Input Power KW	5.71	-	-	-	-
		Output Torque Nm	619	-	-	-	-
15/1	66.7	Input Power KW	5.27	8.88	15.7	21.8	29.3
		Output Torque Nm	632	1080	1980	2760	3740
15/1	66.7	Input Power KW	5.27	8.88	15.7	21.8	29.3
		Output Torque Nm	632	1080	1980	2760	3740
20/1	50	Input Power KW	4.59	8.22	12.6	16.9	23.1
		Output Torque Nm	719	1320	2100	2770	3830
25/1	40	Input Power KW	3.78	6.31	9.90	15.4	21.1
		Output Torque Nm	716	1230	1960	3120	4330
30/1	33.3	Input Power KW	3.38	5.80	8.82	12.3	17.0
		Output Torque Nm	744	1330	2070	2910	4080
35/1	28.6	Input Power KW	-	5.20	7.84	11.0	-
		Output Torque Nm	-	1340	2080	2960	-
40/1	25	Input Power KW	2.78	4.53	7.35	10.6	14.1
		Output Torque Nm	777	1280	2196	3240	4340
50/1	20	Input Power KW	2.13	3.75	6.16	9.31	12.3
		Output Torque Nm	693	1270	2190	3430	4540
60/1	16.7	Input Power KW	1.80	3.27	4.91	7.38	10.4
		Output Torque Nm	678	1310	2010	3120	4450
70/1	14.3	Input Power KW	1.56	2.67	4.21	6.07	8.49
		Output Torque Nm	657	1180	1910	2850	4050

Ratings at 1000 RPM Input Speed

Nominal Ratio	Nominal Output RPM	U & V TYPE UNIT SIZE				O TYPE UNIT SIZE		
		1000	1200	1400	1700	1000	1200	1400
Input Power	- Mechanical	KW	KW	KW	KW	KW	KW	KW
Output Torque	- Mechanical	Nm	Nm	Nm	Nm	Nm	Nm	Nm
Input Power	- Thermal	KW	KW	KW	KW	KW	KW	KW
Output Torque	- Thermal	Nm	Nm	Nm	Nm	Nm	Nm	Nm
5/1	200	97.8 4460 68 3090	145 6630 98.7 4500	202 9070 143 6400	- - - -	97.8 4460 68 3090	145 6630 94.8 4330	202 9070 123 5500
7.5/1	133.3	71 4800 56 3780	109 7430 82.3 5570	148 10100 120 8130	- - - -	71 4800 56.9 3780	109 7430 78.5 5340	148 10100 102 6960
10/1	100	49.2 4290 50 4360	89.2 7860 74 6520	120 10600 112 9840	253 22900 155 14000	49.2 4290 50 4360	89.2 7860 101 6220	120 10500 946 8380
12.5/1	80	- - - -	71.3 7970 68.3 7610	110 12600 95.7 10900	- - - -	- - - -	71.3 7970 64.5 7230	110 12600 76.3 8720
15/1	66.7	43.6 5640 40 5160	62.5 8110 61 7920	114 15100 87.8 11500	190 25100 131 17200	43.6 5640 38.8 5030	62.5 8110 55 7160	114 15100 68 8940
20/1	50	41.6 7080 33.5 5710	65 11100 50.3 8610	92.5 15900 759 13100	161 27900 105 18000	41.6 7080 30.3 5180	65 11100 41.7 7190	92.5 15900 55.8 9670
25/1	40	34.3 7090 27 5580	51 10900 41 8700	73 15400 61 12800	120 25400 82 17300	34.3 7090 23.1 4810	51 10900 32.2 6910	73 15400 43.3 9180
30/1	33.3	29 7090 23.4 5710	46.4 11600 36.7 9110	66.1 17000 52.8 13500	116 29000 76.7 19100	29 7090 19.4 4750	46.4 11600 27.7 6930	66.1 17000 36.2 9390
35/1	28.6	- - - -	36.7 10800 32 9370	- - - -	- - - -	- - - -	36.7 10800 23 6810	- - - -
40/1	25	25 7930 18.3 5790	39 12600 28 9020	54.7 17800 38.3 12400	77.8 25700 58.1 19000	25 7930 13.8 4430	39 12600 19.7 6410	54.7 17800 25 8170
50/1	20	20.83 7960 15.8 5930	31.6 12300 23.2 9030	44.4 17400 31.9 12400	78.3 31100 49.3 19600	20.83 7960 11 4190	31.6 12300 15.1 5930	44.4 17400 19.2 7550
60/1	16.7	17.6 7770 13.6 5980	26.9 12000 19.6 8690	41 18900 29.6 13500	67 31100 43.6 20000	17.6 7770 8.7 3880	26.9 12000 11.6 5240	41 18900 16.3 7590
70/1	14.3	14.5 7270 12.7 6390	23.1 11900 19.2 9800	34 17500 25 12700	57.3 30200 37.1 19200	14.5 7270 7.5 3790	23.1 11900 10.2 5320	34 17500 12.6 6520



Actual Ratings of U900 & V900 Gearboxes

RATIO	CAPACITY	INPUT SPEEDS RPM			
		1500	1000	750	500
6.5/1	Input Power Kw	71.2	54.2	40.4	30.8
	Output Torque Nm	2750	3130	3090	3520
9/1	Input Power Kw	51.2	40.5	34	26
	Output Torque Nm	2780	3270	3640	4050
13/1	Input Power Kw	48.2	35.7	27.4	20
	Output Torque Nm	3620	4000	4060	4380
18/1	Input Power Kw	39	28.7	22.2	16
	Output Torque Nm	3980	4350	4450	4720
22.5/1	Input Power Kw	34.5	25.2	19.7	14
	Output Torque Nm	4340	4690	4850	5040
26/1	Input Power Kw	30.2	22.1	17.3	12.3
	Output Torque Nm	4310	4660	4810	5000
36/1	Input Power Kw	22.4	16.6	12.9	9.4
	Output Torque Nm	4200	4580	4700	4960
44/1	Input Power Kw	19.9	14.6	11.5	8.3
	Output Torque Nm	4450	4800	4970	5160
52/1	Input Power Kw	17.4	12.8	10.1	7.4
	Output Torque Nm	4440	4800	4970	5150
62/1	Input Power Kw	16.4	12.1	9.5	6.9
	Output Torque Nm	4920	5270	5470	5600

Power Rating of Worm Reduction, Size 2000 (20" Crs) Unit

ACTUAL RATIO	CAPACITY	INPUT SPEEDS RPM			
		1500	1000	750	500
12.167/1	Input Power : Mech - Kw	349	275	231	179
	Output Torque : Mech - Nm	2750	3130	3090	3520
	Input Power : Ther - Kw	276	207	164	120
	Output Torque : Ther - Nm	21900	24800	23800	25900
18/1	Input Power : Mech - Kw	252	186	150	109
	Output Torque : Mech - Nm	31700	35100	37500	40500
	Input Power : Ther - Kw	212	163	135	100
	Output Torque : Ther - Nm	25500	29500	33800	37200
23.333/1	Input Power : Mech - Kw	222	164	132	95.7
	Output Torque : Mech - Nm	35600	39500	41900	45300
	Input Power : Ther - Kw	150	116	97	73
	Output Torque : Ther - Nm	22100	25900	30800	34600
29.667/1	Input Power : Mech - Kw	198	147	119	86.2
	Output Torque : Mech - Nm	39600	44200	47000	50800
	Input Power : Ther - Kw	142	109	90	67
	Output Torque : Ther - Nm	24800	26800	35500	39500
35/1	Input Power : Mech - Kw	162	120	97.7	71
	Output Torque : Mech - Nm	37800	42000	44800	48400
	Input Power : Ther - Kw	124	95	80	60
	Output Torque : Ther - Nm	25500	29400	36700	40900
48.5/1	Input Power : Mech - Kw	95.1	70.4	57.1	41.9
	Output Torque : Mech - Nm	29800	33100	35200	38300
	Input Power : Ther - Kw	108	81.3	59	45
	Output Torque : Ther - Nm	30500	34700	36400	41100
60/1	Input Power : Mech - Kw	107	79.9	64.7	47.6
	Output Torque : Mech - Nm	40000	44400	46900	50900
	Input Power : Ther - Kw	67.6	52.6	45	35
	Output Torque : Ther - Nm	21400	25200	32600	37400
72/1	Input Power : Mech - Kw	90	67	55	40
	Output Torque : Mech - Nm	39200	43600	46100	49700
	Input Power : Ther - Kw	60.1	46.7	39	31
	Output Torque : Ther - Nm	21700	25400	32700	38500

Note : Service factors to be applied as given in example (sizes 1000 to 1700) in publication of Premium Energy Transmission Ltd.

Ratings of Gearbox for Gate Application at Input Speed 1500 R.P.M.

Gear Ratio	Output Speed R.P.M.	Capacity	Size Of Unit				
			400	500	600	700	800
50/1	30	Input Power KW	3.4	5.3	8.5	12.8	17.5
		Output Torque Nm	768	1261	2089	3229	4440
60/1	25	Input Power KW	2.8	4.2	7.1	10.9	13.5
		Output Torque Nm	742	1171	2033	3195	4013

Ratings of Gearbox for Gate Application at Input Speed 1000 R.P.M.

Gear Ratio	Output Speed R.P.M.	Capacity	Size Of Unit				
			400	500	600	700	800
50/1	20	Input Power KW	2.8	4.5	6.8	9.6	13.5
		Output Torque Nm	920	1544	2428	3530	4966
60/1	16.7	Input Power KW	2.5	3.7	5.4	8	11
		Output Torque Nm	939	1483	2254	3424	4728

Exact Standard Gear Ratios Single Reduction Units

Nominal Ratio	Size of Unit														
	112	162	200	237	287	337	400	500	600	700	800	1000	1200	1400	1700
5/1	5.25	5.25	4.8	5.0	5.2	4.83	4.83	5.0	4.88	5.0	5.0	4.89	4.9	4.91	-
7.5/1	-	7.33	7.33	7.33	7.25	7.25	7.5	7.4	7.6	7.5	7.5	7.33	7.43	7.71	-
10/1	10.5	10.5	10.5	9.67	10.33	9.67	9.67	9.75	9.75	9.75	9.75	10.25	9.8	9.8	10.17
12.5/1	-	-	-	-	-	-	12.75	-	-	-	-	-	12.25	12.75	-
15/1	14.5	14.5	14.5	15.0	14.5	14.5	14.5	14.5	14.67	14.67	14.67	14.67	14.67	14.75	15.25
20/1	20	19.5	20	20	19.5	19.5	19.5	19.5	20	19.5	19.5	20.5	19.67	19.67	19.67
25/1	25	25	25	25	25	25	25	24.5	24.5	24.5	24.5	25.5	24.5	24.5	24.67
30/1	30	30	30	30	30	30	30	30	30	30	29.5	29.5	29.5	30.5	29.5
35/1	-	-	-	-	-	-	-	35	35	35	-	-	35.5	-	-
40/1	40	40	40	40	40	40	40	40	40	40	40	40	40	40	40.5
50/1	50	50	50	50	50	50	50	50	50	50	50	50	50	50	50
60/1	60	60	60	60	60	60	60	60	60	60	60	60	60	60	60
70/1	70	70	70	70	70	70	70	70	70	70	70	70	70	70	70



Direction of rotation

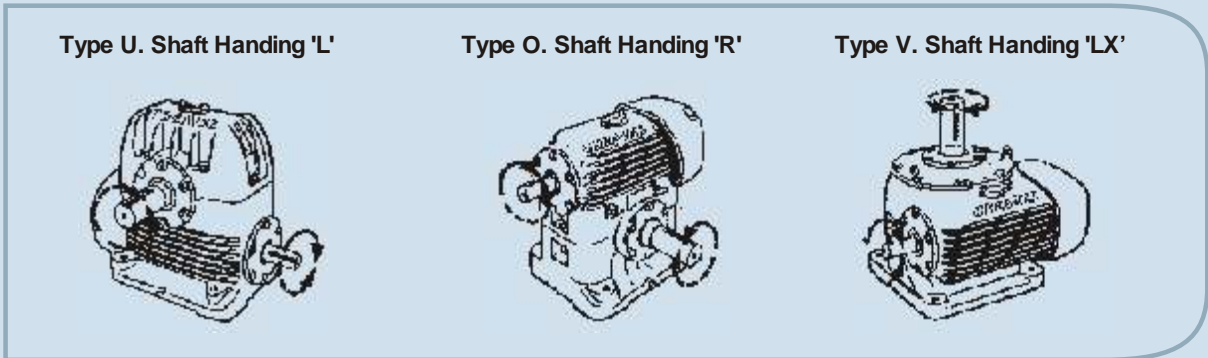

Double Reduction Speed Reducers Ratings Types: AUD-AOD-AVD

Nominal Ratio	Nominal Input	Nominal Output Speed r.p.m.	SIZE OF UNIT									
			162		200		237		287		337	
			Input KW	Output Torque Nm	Input KW	Output Torque Nm	Input KW	Output Torque Nm	Input KW	Output Torque Nm	Input KW	Output Torque Nm
100/1	750	7.50	0.12	103.98	0.29	223.67	0.46	369.84	0.53	481.67	0.80	735.75
	1000	10.0	0.15	97.90	0.36	210.91	0.52	321.77	0.65	454.20	0.94	670.02
	1500	15.0	0.21	89.37	0.43	172.65	0.56	23.40	0.87	413.00	1.06	509.14
150/1	750	5.00	0.11	111.83	0.18	199.14	0.30	316.86	0.44	539.55	0.67	837.77
	1000	6.67	0.14	105.95	0.23	189.33	0.37	300.18	0.54	511.10	0.82	792.65
	1500	10.0	0.18	97.22	0.30	173.64	0.50	266.83	0.73	467.94	1.03	690.62
200/1	750	3.75	0.08	96.33	0.12	177.56	0.21	274.68	0.30	466.95	0.47	730.84
	1000	5.00	0.10	91.72	0.17	168.73	0.26	260.94	0.38	443.41	0.58	693.57
	1500	7.50	0.14	84.85	0.23	155.98	0.36	241.32	0.51	409.08	0.78	638.63
300/1	750	2.50	0.07	122.62	0.15	267.81	0.24	442.43	0.27	576.83	0.41	887.80
	1000	3.33	0.09	117.72	0.18	256.04	0.30	422.81	0.33	551.32	0.51	842.68
	1500	5.00	0.12	109.87	0.26	238.38	0.41	393.38	0.46	513.06	0.56	626.86
400/1	750	1.88	0.07	135.38	0.09	173.64	0.18	406.13	0.21	560.15	0.21	525.81
	1000	2.50	0.09	135.38	0.10	160.88	0.21	390.44	0.26	518.95	0.26	487.56
	1500	3.75	0.12	135.38	0.12	143.22	0.30	367.87	0.32	435.56	0.32	409.08
600/1	750	1.25	0.06	135.38	0.09	230.53	0.12	434.58	0.18	653.34	0.21	739.67
	1000	2.67	0.07	135.38	0.10	214.84	0.17	418.89	0.24	653.34	0.26	687.68
	1500	2.50	0.10	135.38	0.12	190.31	0.24	394.36	0.32	574.86	0.32	577.81
750/1	750	1.00	0.04	101.04	0.06	178.54	0.09	283.51	0.12	495.40	0.18	742.62
	1000	1.33	0.04	96.43	0.07	170.69	0.11	271.74	0.15	472.84	0.23	708.28
	1500	2.00	0.07	90.45	0.10	159.90	0.15	253.10	0.21	440.47	0.30	659.23
1000/1	750	0.75	0.04	135.38	0.08	296.26	0.11	489.52	0.14	654.33	0.21	1059.00
	1000	1.00	0.05	135.38	0.10	285.47	0.14	470.88	0.18	654.33	0.26	990.81
	1500	1.50	0.08	135.38	0.12	259.96	0.18	442.43	0.24	654.33	0.32	839.73
1200/1	750	0.63	0.04	135.38	0.07	272.72	0.10	437.52	0.12	654.33	0.20	1128.00
	1000	0.83	0.05	135.38	0.08	262.91	0.12	420.85	0.15	654.33	0.24	1128.00
	1500	1.25	0.07	135.38	0.11	248.19	0.15	396.32	0.21	654.33	0.32	981.00
2000/1	750	0.38	0.01	114.78	0.04	205.03	0.05	327.65	0.07	572.90	0.11	864.26
	1000	0.50	0.03	110.85	0.05	197.18	0.07	315.88	0.10	552.30	0.12	831.89
	1500	0.75	0.04	105.95	0.07	186.39	0.10	298.22	0.12	519.93	0.18	781.86
2800/1	750	0.27	0.01	101.04	0.03	176.58	0.04	287.43	0.06	480.69	0.08	746.54
	1000	0.36	0.01	97.90	0.04	170.69	0.05	277.62	0.07	464.01	0.10	719.07
	1500	0.54	0.04	92.90	0.05	161.86	0.07	261.93	0.10	437.52	0.14	676.89

Nominal ratios listed are a typical selection of commonly used ratios from the overall range. Details of other ratios available on request.

Direction of rotation



Double Reduction Premium Speed Reducers Ratings Types: UD-OD-VD

Nominal Ratio	Nominal Input Speed r.p.m.	Nominal Output Speed r.p.m.	SIZE OF UNIT									
			400		500		600		700		800	
			Input KW	Output Torque Nm	Input KW	Output Torque Nm	Input KW	Output Torque Nm	Input KW	Output Torque Nm	Input KW	Output Torque Nm
150/1	750	5.00	0.83	972.17	1,53	1805	2,24	2864	3.15	4061	4.29	5709
	1000	6.66	1.07	931.95	1.94	1736	2.76	2737	3.95	3894	5.44	5572
	1500	10.0	1.42	883.88	2.53	15.99	3.65	2531	5.15	3482	7.17	5013
300/1	750	2.50	0.65	1157	1.00	2001	1.45	3345	2.01	4512	2.83	6779
	1000	3.33	0.82	1108	1.31	1913	1.71	3159	2.39	4238	3.43	6386
	1500	5.00	1.04	1000	1.77	1717	2.31	2874	3.21	3924	4.55	5758
500/1	750	1.50	0.46	1255	0.74	2236	1.04	3345	1.42	5140	1.64	6210
	1000	2.00	0.57	1206	0.97	2236	1.24	3345	1.79	4885	2.16	6210
	1500	3.00	0.74	1128	1.28	2080	1.71	3227	2.39	4512	3.13	6210
1000/1	750	0.75	0.30	1275	0.46	2197	0.65	3453	0.89	5140	1.12	6779
	1000	1.00	0.36	1236	0.57	2138	0.74	3384	1.12	5140	1.42	6779
	1500	1.50	0.48	1177	0.74	2030	1.06	3335	1.64	5140	2.01	6661
2000/1	750	0.38	0.19	1275	0.33	2246	0.35	3119	0.55	5199	0.74	7112
	1000	0.50	0.24	1236	0.41	2168	0.45	3119	0.67	5199	0.97	7112
	1500	0.75	0.32	1206	0.54	2109	0.61	3119	0.97	5199	1.27	7112
3000/1	750	0.25	0.12	1089	0.24	2374	0.27	2864	0.46	5307	0.59	7455
	1000	0.33	0.15	1089	0.30	2286	0.36	2864	0.56	5307	0.74	7455
	1500	0.50	0.21	1089	0.39	2109	0.48	2864	0.74	5307	1.04	7112

Nominal ratios listed are a typical selection of commonly used ratios from the overall range.
 Details of other ratios available on request.



Direction of rotation

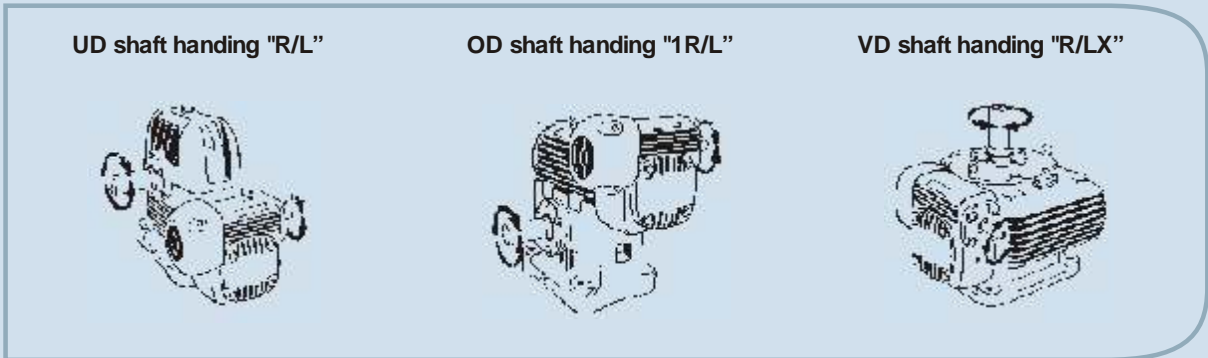

Double Reduction Speed Reducers Ratings Types: UD-OD-VD

Nominal Ratio	Nominal Input Speed r.p.m.	Nominal Output Speed r.p.m.	SIZE OF UNIT							
			1000		1200		1400		1700	
			Input KW	Output Torque Nm	Input KW	Output Torque Nm	Input KW	Output Torque Nm	Input KW	Output Torque Nm
150/1	750	5.00	7.46	10055	10.44	15931	13.4	19659	23.87	38426
	1000	6.66	8.95	1378	12.68	14921	17.16	18874	30.58	36728
	1500	10.0	11.19	8191	16.41	12998	23.12	17403	41.03	33903
300/1	750	2.50	4.32	10791	5.52	14803	9.70	25427	15.66	42948
	1000	3.33	5.44	10281	6.93	14126	11.93	24074	20.14	41251
	1500	5.00	7.01	9211	8.95	12939	15.66	21238	26.85	37288
500/1	750	1.50	2.91	11870	3.58	14401	5.15	21474	9.70	40682
	1000	2.00	3.58	11242	4.69	14401	6.79	21474	12.68	40682
	1500	3.00	4.85	10055	6.86	14401	9.70	21474	17.90	40682
1000/1	750	0.75	1.64	10173	2.76	19433	3.80	25535	6.12	45773
	1000	1.00	2.16	10173	3.50	19041	4.55	25535	7.46	45773
	1500	1.50	3.13	10173	4.84	18080	6.64	25535	11.19	45773
2000/1	750	0.38	0.82	11634	1.56	19208	2.24	27124	3.88	50286
	1000	0.50	1.04	11634	2.01	19208	2.83	27124	5.15	50286
	1500	0.75	1.56	11634	2.90	19208	4.10	27124	7.46	50286
3000/1	750	0.25	0.74	11075	1.11	17403	1.56	25761	2.61	46332
	1000	0.33	0.97	11075	1.49	17403	2.01	25761	3.36	46332
	1500	0.50	1.42	1075	2.16	17403	2.91	25761	4.70	46332

Nominal ratios listed are a typical selection of commonly used ratios from the overall range. Details of other ratios available on request.

Heliworm Speed Reducers Ratings Types : BSU-BSO-BSV

Nominal Ratio	Nominal Input Speed r.p.m.	Nominal Output Speed r.p.m.	SIZE OF UNIT															
			400		500		600		700		800		1000		1200		1400	
			Input KW	Output Torque Nm	Input KW	Output Torque Nm	Input KW	Output Torque Nm	Input KW	Output Torque Nm	Input KW	Output Torque Nm	Input KW	Output Torque Nm	Input KW	Output Torque Nm	Input KW	Output Torque Nm
80/1	750	9.38	1.21	903.7	2.14	1683	3.32	2628	4.37	3524	5.67	4710	6.38	5648	10.44	8472	15.89	13555
	1000	12.50	1.48	847.2	2.62	1570	4.06	2530	5.34	3321	6.79	4439	8.20	5479	12.31	8077	20.14	12991
	1500	18.75	1.92	746.7	3.19	1299	5.27	2236	6.73	2903	9.55	4100	11.41	5196	16.11	7229	26.85	11861
100/1	750	7.50	1.008	81.1	1.52	1423	2.46	2440	3.74	3750	5.00	5083	5.33	5648	7.87	8472	13.43	14233
	1000	10.00	1.198	13.3	1.93	1378	3.17	2304	4.77	3682	6.26	4857	6.86	5535	10.26	8077	16.71	13104
	1500	15.00	1.527	11.6	2.59	1265	4.04	2033	6.39	3344	8.13	4292	9.51	5219	13.35	7229	20.44	10844
120/1	750	6.25	0.89	903.7	1.36	1649	2.36	2598	3.18	3660	4.03	4744	4.77	5648	6.86	8472	10.52	13329
	1000	8.33	1.07	847.2	1.92	1559	2.97	2485	4.01	3502	5.07	4518	6.04	5535	8.59	8077	12.90	12426
	1500	12.05	1.41	756.8	2.46	1389	3.86	2259	5.25	3140	6.79	4157	8.35	5219	11.11	7229	16.26	10618
160/1	750	4.69	0.72	915.0	1.20	1525	1.98	2711	2.65	3841	3.39	4970	3.88	5648	5.63	8472	9.99	15363
	1000	6.25	0.89	869.8	1.48	1446	2.43	2575	3.29	3660	4.21	4801	4.96	5535	6.94	8077	11.7	13781
	1500	9.36	1.17	790.7	1.92	1310	3.15	2327	4.37	3344	5.78	4383	6.79	5219	9.06	7229	13.05	10618
200/1	750	3.75	0.55	790.7	0.98	1468	1.53	2553	2.20	3795	3.03	5253	3.17	5648	4.68	8472	7.46	13555
	1000	5.00	0.68	756.8	1.21	1401	1.95	2429	2.74	3660	3.77	5027	4.03	5535	5.80	8077	9.32	13104
	1500	7.50	0.89	689.1	1.56	1276	2.53	2214	3.67	3366	4.92	4575	5.44	5219	7.44	7229	12.38	11861
240/1	750	3.13	0.41	677.8	0.84	1468	1.24	2270	1.83	3569	2.55	5027	2.77	5648	4.03	8472	6.49	13555
	1000	4.17	0.55	711.6	0.97	1310	1.54	2169	2.15	3231	3.16	4801	3.50	5535	5.07	8077	7.91	12878
	1500	6.25	0.72	655.2	1.26	1209	1.97	1920	2.65	2790	4.14	4383	4.81	5219	6.53	7229	10.44	11861
Output Torque For Standard Shafts	Normal Overload		960.2 1920		1355 2711		2203 4405		2937 5874		3841 7681		5648 11296		8811 17622		15815 31629	

Exact Ratios ** - BSU-BSO-BSV

Nominal Ratio	SIZE OF UNIT							
	400	500	600	700	800	1000	1200	1400
80/1	78.00	78.00	81.25	81.44	81.44	85.42	81.96	79.72
100/1	100.00	98.00	99.53	102.32	102.32	106.25	102.08	99.29
120/1	120.00	120.00	121.88	125.29	123.20	122.92	122.92	123.61
160/1	160.00	160.00	162.50	167.06	167.06	166.67	166.70	162.11
200/1	200.00	200.00	203.13	208.82	208.82	208.33	208.33	202.63
240/1	240.00	240.00	243.75	250.59	250.59	250.00	250.00	243.16

If the ACTUAL output torque required exceeds the figure shown in bold type at the foot of the table consideration should be given to the use of additional keys etc. in the output shaft. **Ratios, Inputs Speeds and Output Speeds are nominal. Exact equivalent standard ratios are listed below.

Direction of rotation

BSU shaft handing "1/L"

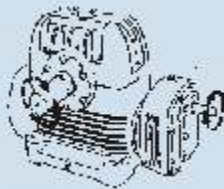

BSU shaft handing "3/L"



BSV shaft handing "1/LX"

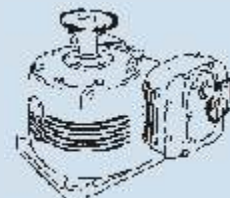



Overhung Loads Single Reduction Units

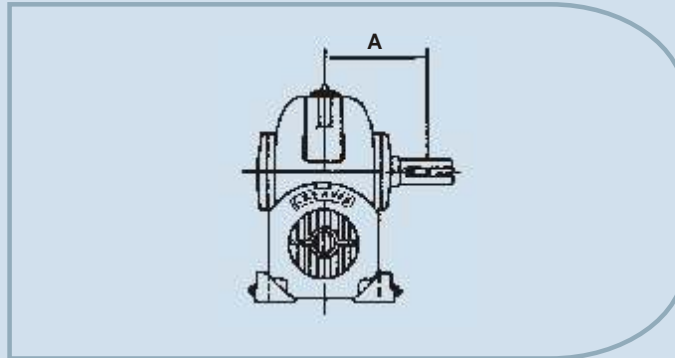

Premium speed reducers are fitted with taper roller bearings of generous proportions which in addition to accommodating normal loads imposed by the worm gears, have an ample margin for taking overhung loads. In cases where external loads are applied in excess of this margin, wider taper roller bearings and wheel shafts of high tensile material can be fitted without any alteration to standard units, Whenever a sprocket, gear, sheave or pulley is mounted on the output shaft, a calculation should be made to determine the overhung load in Newtons on the shaft, using the formula :

$$P = \frac{KW \times 9.550,000 \times K}{N \times R}$$

Where, P = equivalent overhung load in Newtons

KW = power carried by shaft in Kilo Watts

N = r.p.m, of the shaft

R = pitch radius of sprocket, pinion, sheave or pulley in mm

K = factor

Overhung Member	K Factor
Sprocket, Single Strand	1.00
Spur Pinion	1.25
V-belt Sheave	1.50
Flat Belt Pulley	2.00

The calculated equivalent overhung load should be compared with the permissible values given in the table. These tabulated values are based on an input speed of 1500 rpm, with the unit transmitting full rated power and the direction of overhung load in the most unfavourable direction. Hence they can sometimes be increased for lesser input speed, or if the power transmitted is less than the rated capacity of the gear unit, or if the load is applied nearer to the gear unit case, or if the direction of load is more favourable. In any event the sprocket, gear etc., should be positioned as close as possible to the gear unit case in order to reduce bearing loads and shaft stresses and to prolong life.



Maximum Permissible Overhung Loads (newtons) at centre of wheel shaft extension at 1,500 R.P.M. Input Speed.

Size Unit	Distance A (mm)	Type of bearing/ Wheelshaft Material	Nominal Ratio												
			5/1	7.5/1	10/1	12.5/1	15/1	20/1	25/1	30/1	35/1	40/1	50/1	60/1	70/1
112	62	Standard	801	-	1060	-	1070	1060	1060	1060	-	1070	1050	1000	935
162	75	Standard	2780	2750	2640	-	2530	2590	2440	2430	-	2510	2610	2720	2770
200	89	Standard	4400	4380	4180	-	4120	3900	3910	3960	-	4030	4150	4320	4430
237	105	Standard	5630	5610	5520	-	5290	4920	4940	5080	-	5210	5320	5480	5620
287	127	Standard	5030	4830	4640	-	3890	3990	3100	3170	-	3620	3890	4310	4790
337	151	Standard	9120	9520	9330	-	8720	8810	8370	8170	-	8470	8820	9020	9400
400	171	Standard WTR + HTS	11500 12800	12600 15100	12300 16500	12100 17600	12000 18700	11600 19800	11600 19800	11400 19700	-	11200 19600	11700 19900	11700 19900	11800 20000
500	197	Standard WTR + HTS	14500 20300	16600 23200	17800 25500	-	17800 29500	16800 29100	17100 29300	16500 28800	16400 28900	16900 29200	16900 29200	16700 29100	17300 29400
600	216	Standard WTR + HTS	15000 22000	18600 26600	19400 29400	-	17400 32100	16800 31700	17600 32100	16200 31400	16200 31400	15500 31100	16000 31300	17100 31900	17600 32200
700	235	Standard WTR + HTS	17400 21900	20800 25800	24200 29600	-	25300 33500	25200 37400	23500 39800	23900 42700	24100 44100	22600 43300	21500 42700	23300 43700	24600 44400
800	241	Standard WTR + HTS	17400 25000	21300 29800	25700 34900	-	28700 39400	28200 43900	25200 46800	26800 50700	-	25000 51000	23300 50200	23900 50500	26500 51800
1000	298	Standard WTR + HTS	19500 29900	24700 36400	30100 42800	-	32900 48700	30100 52300	30900 57000	30200 60200	-	29800 60000	29100 59700	28900 59600	25500 58000
1200	327	Standard WTR + HTS	24600 37000	29700 43700	36200 51300	40400 57500	39700 61700	35000 65200	34500 72500	31700 73700	29600 72900	32300 74000	32000 73900	34600 75100	25800 71400
1400	387	Standard WTR + HTS	41900 76100	48900 87400	57300 99100	61900 10700	64000 111000	73000 124000	81600 136000	85100 144000	-	88500 151000	88500 151000	85100 149000	87400 151000
1700	445	Standard WTR + HTS	-	-	58200 126000	-	71800 148000	81900 165000	94200 182000	98600 192000	-	11400 213000	118000 212000	122000 211000	125000 213000

WTR = Wider Taper Roller Bearing.

HTS = High Tensile Steel.

Above ratings are based on least of the thermal and mechanical output torque ratings with service factor one.



PREMIUM

Premium Energy Transmission Limited

Head Office : PB No. 5, Chinchwad , Pune - 411 019, India.
Tel. : (91-20)27475141/42/43/44 Fax : (91-20)27450287,27476601.
Website : www.premiumtransmission.com

Branch Offices :

Western Region :

Mumbai : Industry Manor, Appasaheb Marathe Marg, Prabhadevi , Mumbai - 400 025.
Tel. : (91-22)24223747,24365510, Fax : (91-22)24377730.

Ahmedabad : "Jaldarshan", Ashram Road , Navrangpura , Ahmedabad - 380 009.
Tel. : (91-79)26580428/0518/1861 Fax : (91-79)26587783.

Nagpur : "Guman", Pandit Jawaharlal Nehru Marg, Sadar, P.B. No. 129, Nagpur - 440 001.
Tel. : (91-712)2526588,2524125,2526038, Fax : (91-712)2541142.

Northern Region :

New Delhi : Express Building Annexe , 9-10, Bahadur Shah Zafar Marg, New Delhi - 110 002.
Tel. : (91-11)23730554(8 lines), Fax : (91-11)23359782.

Eastern Region :

Kolkata : Thapar House, 25, Brabourne Road , P.B. No. 702, Kolkata - 700 001.
Tel. : (91-33)22423811,22423780,22423805, Fax : (91-33)22424325.

Ranchi : Rani Kuthi, 82, Burdwan Compound , P.B. No. 139, Ranchi - 834 001.
Tel. : (91-651)2562651, Fax : (91-651)2562027.

Southern Region :

Chennai : "Wavoo Mansion", 6th Floor, New No. 48, (Old No. 39), Rajaji Salai, Chennai - 600 001.
Tel. : (91-44)25240142, Fax : (91-44)25224557.

Bangalore : 16/3, Ali Asker Road , P.B. No. 216, Bangalore - 560 052.
Tel. : (91-80)22268773/2506, Fax : (91-80)22253472.

Hyderabad : 6-2-47, A. C. Guards , 1st floor, P.B. No. 9, Hyderabad - 500 004.
Tel. : (91-40)23314025,23390544,23316446, Fax : (91-40)23318557.

Kochi : 39/5567, M. G. Road , Ernakulam, Kochi - 682 015.
Tel. : (91-484)2359190,2359372, Telefax : (91-484)2359589.





ADAPTABLE SPEED REDUCERS



PREMIUM ADAPTABLE SPEED REDUCERS

Premium Adaptable Speed Reducers are available in a range of six sizes from size 112 to 337 (28.6 to 85.7 mm centres) and meets the requirement of all drives upto 7.5 kw. A range of standard ratios gives a wide choice of output speeds.

The number of mounting arrangements of adaptable units is almost unlimited, giving the widest possible field of application. The same basic case is used for each size and can be mounted using detachable feet or, where desired, can be located without feet. The drawing of dimensions gives case details together with sizes for Nos. 1, 2 and 3 feet.

Alternative basic shaft handing arrangements are available, R and L. These references should always be quoted, together with feet details.

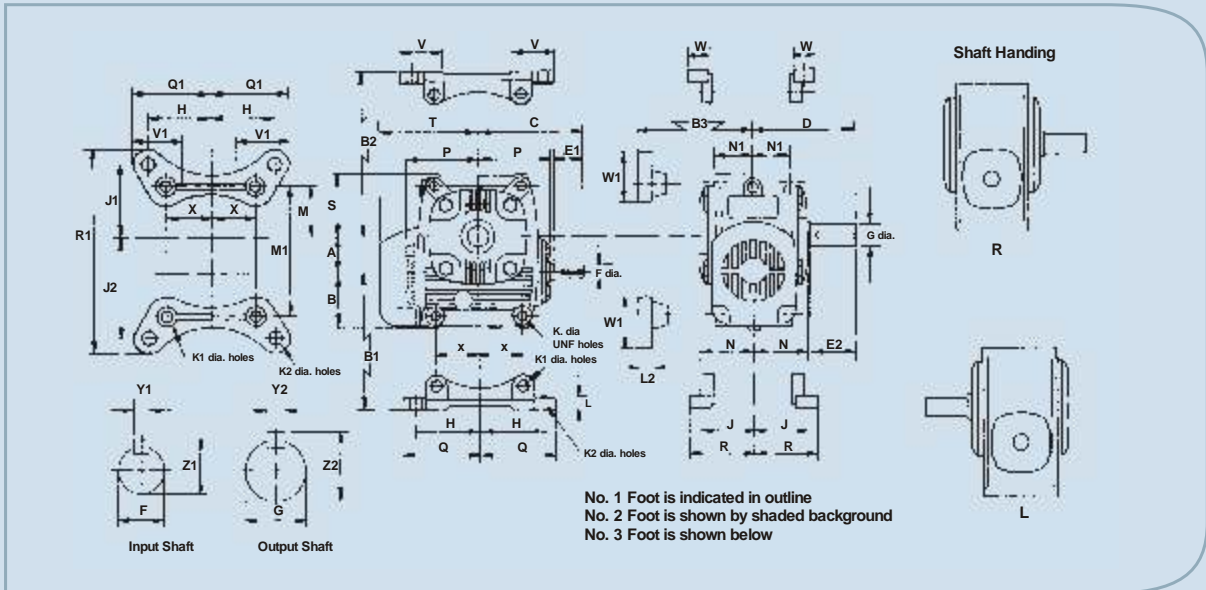

Principal Dimensions (mm)

SIZE	A	B	C	D	E1	E2	E3	E4	F	G	K	M
112	28.6	44.5	90	79	29	35	25.4	32	11.113 11.102	15.875 15.865	6.4	41.3
162	41.3	50.8	110	98	41	48	38	44	15.875 15.865	19.050 19.037	6.4	47.6
200	50.8	58.7	133	117	48	57	44	54	5.875 15.865	25.400 25.387	7.9	60.3
237	60.3	68.3	159	140	57	70	54	67	19.050 19.037	28.575 28.562	9.5	71.4
287	73.0	77.8	191	168	70	83	67	79	22.225 22.212	31.750 31.735	11.1	88.9
337	85.7	90.6	219	200	83	98	79	95	25.400 25.387	38.100 38.085	12.7	100.0

SIZE	M1	N	N1	P	S	T	X	Y1	Y2	Z1	Z2
112	104.8	41	30	62	51	81	34.9	3.226 3.175	4.826 4.775	12.50 12.29	17.98 17.78
162	130.2	49	37	71	57	89	39.7	4.826 4.775	4.826 4.775	17.98 17.78	21.16 20.96
200	158.8	59	43	86	71	111	50.8	4.826 4.775	6.408 6.350	17.98 17.78	28.19 27.99
237	187.3	68	51	98	84	130	60.3	4.826 4.775	7.976 7.925	21.16 20.96	32.05 31.85
287	225.4	81	64	119	103	154	76.2	6.401 6.350	7.976 7.925	25.02 24.82	35.23 35.03
337	260.4	98	76	133	116	175	85.7	6.401 6.350	9.576 9.525	28.19 27.99	42.27 42.06



Mounting Arrangement

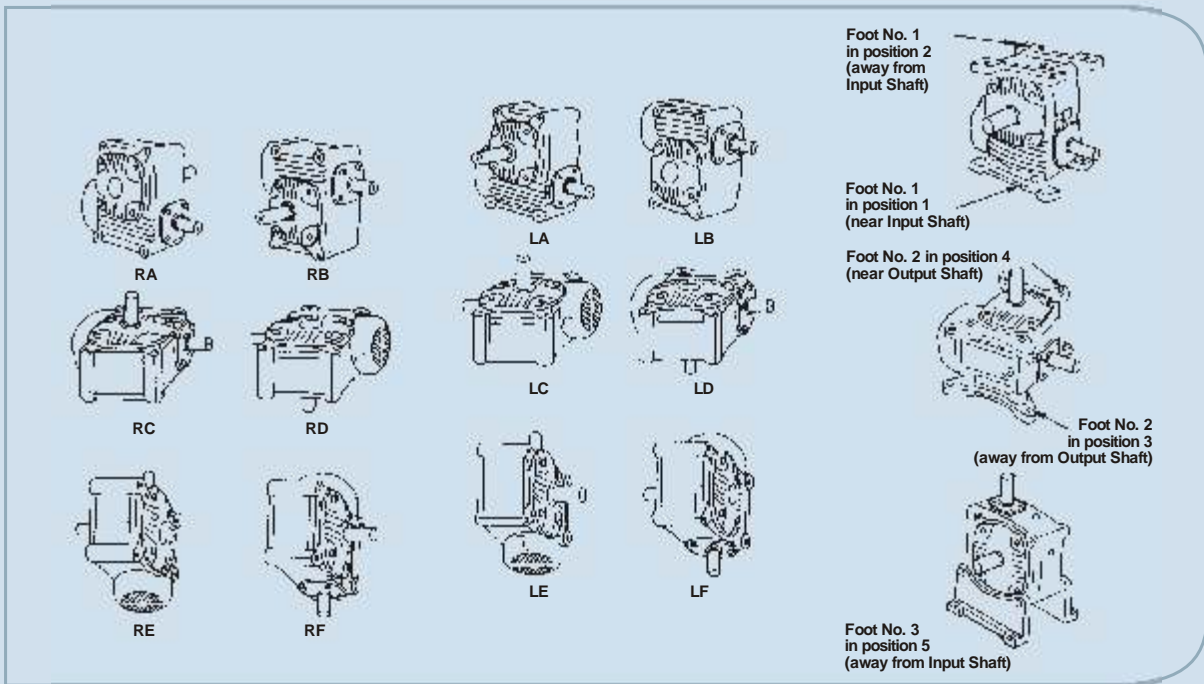

Handling & Mounting

Adaptable Premium Speed Reducers can be mounted in an almost unlimited number of different positions. The diagrams above indicate typical commonly used "space" dispositions of Adaptables showing the numerous shaft arrangements. The three types of feet, as shown on page 2, can be used in all these positions.

The two basic unit positions are shown under the headings "right handing - R" and "left handing - L" where the unit is arranged in the upright position, with shafts in the horizontal plane and the high speed shaft located under the slow speed shaft.

A right hand unit is one where, when looking on the end of the high speed shaft, the slow speed shaft extensions is to the right. Similarly, a left hand unit has the slow speed shaft extensions to the left.

Oil level, breather and drain plugs are arranged to suit these basic positions. Where units are mounted in other positions it is necessary to change the positions of the breather. The diagrams on page 8 show plug positions for the different mounting

Enquires

It is recommended that as much as possible of the following information be given on enquiry or order so that a check can be made, and advice given on the most suitable size of Greaves for any particular application.

1. Quantity
2. Prime mover
3. Horse-power of prime mover
4. Output torque required from driven member
5. Input speed of gear unit
6. Output speed of gear unit
7. Application of drive

Typical Catalogue Number

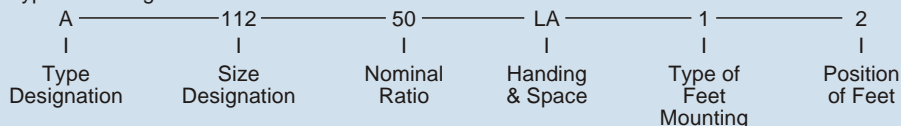

Full details from the nameplate should be specified for spare parts.

Oil capacity and shipping specification

	Size of unit					
	112	162	200	237	287	337
Net Weight (kg.)	5	7	13	20	31	49
Gross Weight (kg.)	5	8	14	21	34	50
Volume Packed (cu.m.)	0.004	0.007	0.013	0.022	0.034	0.048
Oil Required at 1st filling (lit.)	0.14	0.28	0.28	0.57	0.85	1.42

A supply of oil is not included in any unit



Motorised units

Adaptable Premium speed reducers can be supplied with integral flange mounted motors. Depending on size, units may carry or be carried by the motors. A range of standard flange adaptors is available for all sizes. Motor flange details should be supplied where customers' motors are fitted. Motorised units can be mounted in any position.

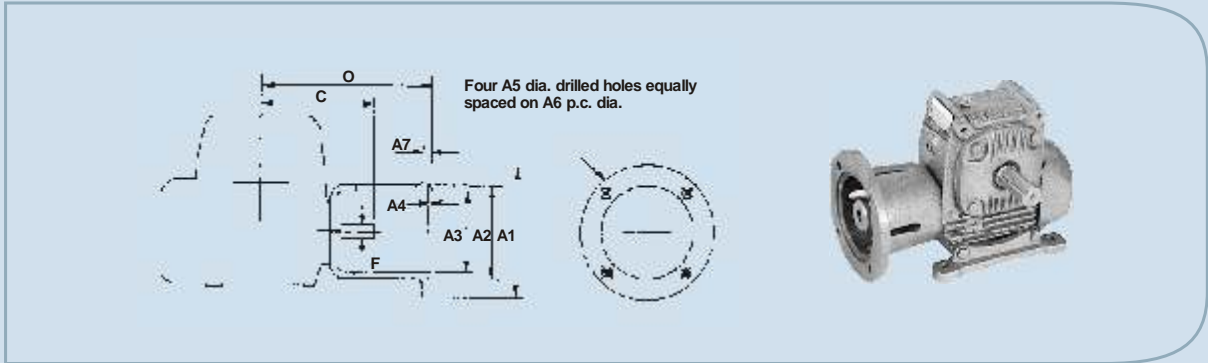

Input shaft and adaptor flange details (mm)

UNIT SIZE	MOTOR FRAME SIZE	A1	A2	A3	A4	A5	A6	A7	C	F	O
112	B.S. 56 D	165	120.700 120.650	105	3.9	8.7	139.7	11	90	11.113 11.102	147.6
	63	140	95.047 95.012	81		11.1	115.0				127.0
	71	160	110.047 110.012	86			130.0				127.0
162	B.S. 56 D	165	120.700 120.650	105	3.9	8.7	139.7	11	110	15.875 15.865	166.7
	63	140	95.047 95.012	95	6.4	*	115.0				149.2
	71	160	110.047 110.012	97	4.7	11.1	130.0				155.6
	80, 90	200	130.054 130.014	121		11.9	165.0				175.4
200	B.S. 56 D	165	120.700 120.650	105	3.9	8.7	139.7	11	133	15.875 15.865	190.5
	63	140	95.047 95.012	95	6.4	*	115.0				163.5
	71	160	110.047 110.012	97	4.7	11.1	130.0				169.9
	80, 90	200	130.054 130.014	121		11.9	165.0				189.7
237	B.S. 56 D	165	120.700 120.650	105	3.9	8.7	139.7	11	159	19.050 19.037	215.9
	63	140	95.047 95.012	94	5.5	*	115.0	13			187.3
	71	160	110.047 110.012	102		*	130.0	11			193.7
	80, 90	200	130.054 130.014	121		11.9	165.0	11			215.1
287	71	160	110.047 110.012	86		9.5	*	130.0	10	191	22.225 22.212
	80, 90	200	130.054 130.014	121	5.5	11.9	165.0	11	246.9		
	100, 112	250	180.054 180.014	170	4.7	14.3	215.0	13	256.8		
337	80, 90	200	130.054 130.014	130	11.1	*	165.0	11	219	25.400 25.387	275.4
	100, 112	250	180.054 180.014	170	4.7	14.3	215.0	13			285.8

Lubrication

The diagrams illustrate typical arrangements of mounting and gives details of the respective positions of Breather, Oil Level and Drain Plugs. Normally units are despatched with plugs fitted as shown in the first diagram, which shows the basic "space" mounting. Where units are required to operate in other positions, it is necessary to reposition the Breather Plug as indicated. The Breather Plug should always be kept clean and free from blockage.

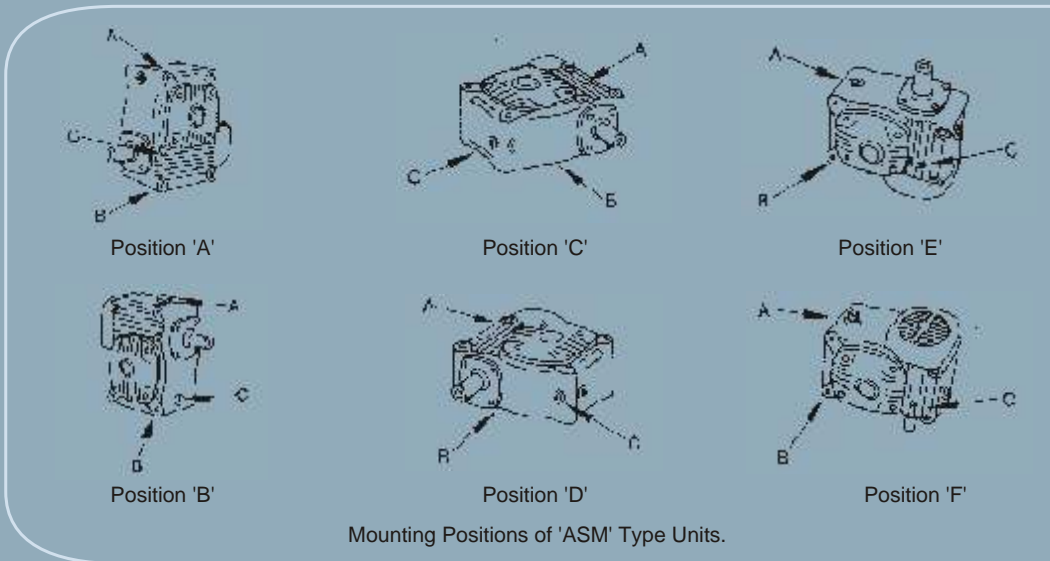

Recommended Lubricant
GREAVES TRAXOL - G32



Premium Energy Transmission Limited

Head Office : P. B. No. 5, Chinchwad, Pune - 411 019, India.

Tel. : (91-20) 27475141 / 42 / 43 / 44, Fax : (91-20) 27450287, 27476601.

Website : www.premiumtransmission.com

Manufacturing Units : • Unit-I : Chinchwad, Pune. Tel. : (91-20) 27475141 / 42 / 43 / 44, Fax : (91-20) 27450287, 27476601. • Unit-II : West Bengal. Tel.: (91-3174) 222231 / 32 / 33 / 37, Fax : (91-3174) 222234. • Unit-III : Chlkalthana, Aurangabad. Tel.: (91-240) 2485521, 2485856, 2485056, Fax : (91-240) 2485756. • Unit-IV : Chlkalthana, Aurangabad. Tel.: (91-240) 2482858, 2471298, Fax : (91-240) 2482857.

Regional Offices : • Mumbai : Tel.: (91-22) 24223747, 24365510, Fax : (91-22) 24367785, 24379555. • New Delhi : Tel. : (91-11) 23730554 (8 Lines), Fax : (91-11) 23359782 / 23357739. • Kolkata : Tel.: (91-33) 22424316, 22423780, 22423805, 22424317 / 20 / 21, 22438815, 22420817, Fax : (91-33) 22424325. • Chennai : Tel.: (91-44) 25255200, (91-44) 25224557.

Branch Office : Ahmedabad : Tel.: (91-79) 26580428 / 0518 / 1856 / 1857 / 1861, Fax : (91-79) 26587783. Nagpur : Tel.: (91-712) 2526588, 2524125, 2526038, Fax : (91-712) 2541142. Ranchi : Tel.: (91-651) 2562069, 2562651, Fax : (91-651) 2562027. Bangalore : Tel.: (91-80) 22262062, Fax : (91-80) 22253472. Hyderabad : Tel.: (91-40) 23314025, 23316446, 23390544, Fax : (91-40) 23318557. Kochi : Tel.: (91-484) 2359661, 2359372, 2359190, Fax : (91-484) 2359589.

Representative Offices : Surat : Tel.: (91-261) 22683330, Mob.: 09825404016. Indore : Tel.: (91-731) 2421135, Mob.: 09826041910. Lucknow : Tel.: (91-522) 3954033, 2344962, Mob.: 09415086044. Ludhiana : Mob.: 09814640863. Coimbatore : Mob.: (91-422) 3220388. Rourkela : Mob.: 09437248230.



Worms and Wormwheels

Standard Adaptable Premium Worms and Wheels can be supplied loose to meet customer requirements where it is found impossible to install complete units. Ratios from 5/1 to 70/1 are available for sizes shown below.

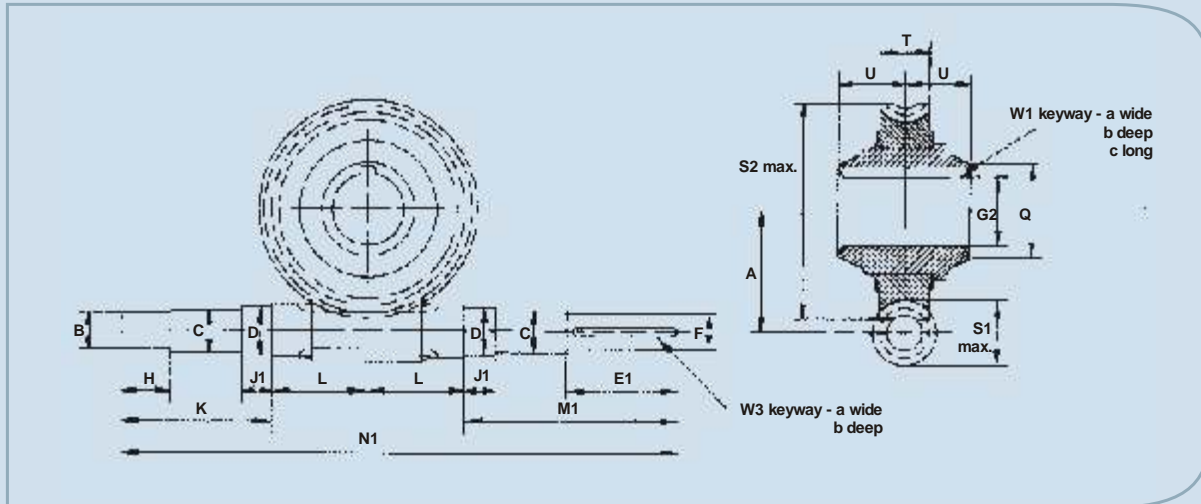

Principal Dimensions (mm)

SIZE	A	B	C	D	E1	E3	F	G2	H	J1	K	L	M1	N1	Q	S1	S2	T	U	W1			W3	
																				a	b	c	a	b
112	28.6	11.1	11.9	12.009 11.994	29	25.4	11.113 11.102	17.475 17.450	13	13	45	30	60	165	26	21	48	13	17	3.175	2.0	25.4	4.763	2.4
162	41.3	15.9	19.8	20.013 19.997	41	38	15.875 15.865	25.415 25.385	16	14	51	33	76	193	33	25	72	16	18	4.763	2.8	38.1	4.763	2.4
200	50.8	15.9	19.8	20.013 19.997	48	44	15.875 15.865	30.973 30.942	21	14	64	42	91	239	40	33	89	22	29	4.763	2.8	44.5	6.350	2.8
237	60.3	19.1	19.8	20.013 19.997	57	54	19.050 19.037	35.728 35.697	23	14	75	49	110	283	46	37	106	25	33	4.763	2.8	54.0	7.938	3.6
287	73.0	22.2	23.8	25.014 24.999	70	67	22.225 22.212	35.728 35.697	28	17	87	62	129	340	46	41	129	29	48	6.350	3.6	66.7	7.938	3.6
337	85.7	25.4	28.6	30.013 29.997	83	69	25.400 25.387	46.055 46.020	32	21	95	73	146	387	58	48	151	32	60	6.350	3.6	79.4	9.252	4.4

Shaft tolerances conform to B.S. 1916 : 1962, h6 Keyways are to B.S. 46 : 1958

Standard Gear Ratios

SIZE	RATIOS										
112	5	-	10	15	20	25	30	40	50	60	70
162	5	7.5	10	15	20	25	30	40	50	60	70
200	5	7.5	10	15	20	25	30	40	50	60	70
237	5	7.5	10	15	20	25	30	40	50	60	70
287	5	7.5	10	15	20	25	30	40	50	60	70
337	5	7.5	10	15	20	25	30	40	50	60	70



SINGLE REDUCTION SPEED REDUCER



GU - TYPE



Premium Speed Reducers are of substantial construction, combining rigidity with strength.

The worm is of high quality case-hardening steel, accurately generated, ground and super-finished. The worm wheel comprises a phosphor bronze centrifugally cast rim of substantial section welded to a rigid centre, which is pressed and keyed to the shaft.

Shafts are located on dual purpose bearings of ample capacity and having a substantial margin on output shafts for accommodating overhung loads. Lubrication is positive at all speeds, in either direction of rotation and apart from an occasional oil check, no attention is necessary in service.

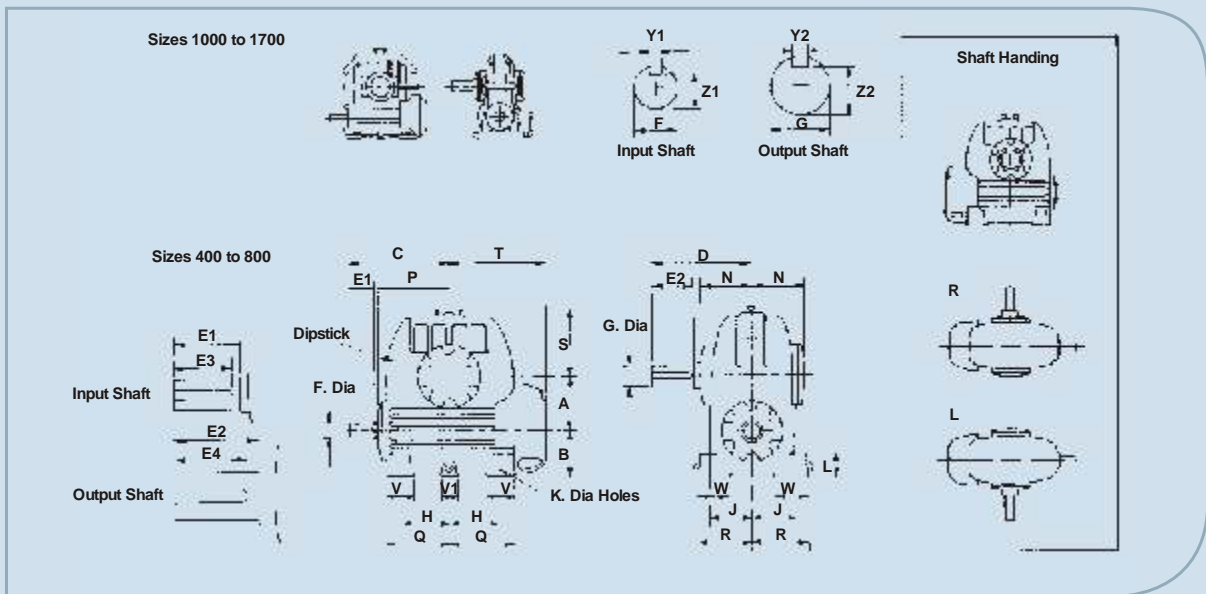

Principal Dimensions (mm)

SIZE	A	B	C	D	E1	E2	E3	E4	F	G	H	J	K
400	101.6	108.0	229	216	67	89	54	83	31.750 31.735	44.450 44.435	108.0	101.6	20.6
500	127.0	114.3	260	248	73	102	73	95	38.100 38.085	50.800 50.782	123.8	111.1	20.6
600	152.4	127.0	279	273	76	114	73	114	38.100 38.085	57.150 57.135	133.4	120.7	23.8
700	177.8	146.1	318	298	86	127	83	114	44.450 44.435	63.500 63.482	152.4	133.4	23.8
800	203.2	146.1	343	311	89	140	83	127	44.450 44.435	69.850 69.832	171.5	133.4	27.0
1000	254.0	171.5	425	375	121	152	89	143	57.150 57.135	82.550 82.527	215.9	165.1	31.8
1200	304.8	190.5	495	413	124	171	89	162	63.500 63.482	95.250 95.227	260.4	184.2	34.9
1400	355.6	215.9	572	483	149	191	146	210	76.200 76.182	114.300 114.277	298.5	215.9	41.3
1700	431.8	254.0	699	546	181	203	152	222	82.550 82.527	139.700 139.675	381.0	254.0	41.3



SIZE	L	N	P	Q	R	S	T	V	V1	W	Y1	Y2	Z1	Z2
400	44	121	159	140	127	137	222	64	-	76	7.976 7.925	11.176 11.125	34.47 34.24	47.73 47.50
500	54	133	184	164	137	159	254	70	-	83	9.576 9.525	12.751 12.700	40.72 40.49	53.98 53.75
600	64	140	200	179	149	184	270	76	-	89	9.576 9.525	15.926 15.875	40.72 40.49	61.75 61.52
700	70	151	229	208	162	210	305	89	-	98	11.176 11.125	15.926 15.875	47.73 47.50	68.10 67.87
800	76	159	251	230	171	235	327	102	-	102	11.176 11.125	19.101 19.050	47.73 47.50	75.03 74.80
1000	51	194	311	298	200	292	378	127	64	200	15.926 15.875	22.276 22.225	61.75 61.52	89.13 88.87
1200	57	216	368	356	222	343	441	152	76	222	15.926 15.875	25.476 25.400	68.10 67.87	103.20 102.95
1400	64	254	425	413	260	394	521	178	89	260	19.101 19.050	31.826 31.750	81.38 81.15	123.47 123.22
1700	76	305	514	502	298	489	629	191	127	298	22.276 22.225	38.202 38.100	89.13 88.90	150.04 149.73

STANDARD NOMINAL RATIOS													
400	5	7.5	10	12.5	15	20	25	30	-	40	50	60	70
500	5	7.5	10	-	15	20	25	30	35	40	50	60	70
600	5	7.5	10	-	15	20	25	30	35	40	50	60	70
700	5	7.5	10	-	15	20	25	30	35	40	50	60	70
800	5	7.5	10	-	15	20	25	30	-	40	50	60	70
1000	5	7.5	10	-	15	20	25	30	-	40	50	60	70
1200	5	7.5	10	12.5	15	20	25	30	35	40	50	60	70
1400	5	7.5	10	12.5	15	20	25	30	-	40	50	60	70
1700	-		10	-	15	20	25	30	-	40	50	60	70

Approximate Shipping Specification and Oil Capacities

Size	400	500	600	700	800	1000	1200	1400	1700
Net weight (kg)	68	95	125	172	218	350	540	864	1340
Gross weight (kg)	79	109	140	191	244	395	635	928	1440
Volume packed (cu. m.)	.08	.12	.15	.21	.27	.48	.76	1.1	1.7
Oil required at 1st filling (lit)	3.0	4.3	6.3	9.1	11.4	15.9	22.7	36.4	45

As improvements in design are continually being made, this specification is not regarded as binding in detail, and dimensions are subject to alteration without notice.



GV - TYPE



Premium Speed Reducers are of substantial construction, combining rigidity with strength.

The worm is of high quality case-hardening steel, accurately generated, ground and super-finished. The worm wheel comprises a phosphor bronze centrifugally cast rim of substantial section welded to a rigid centre, which is pressed and keyed to the shaft.

Shafts are located on dual purpose bearings of ample capacity and having a substantial margin on output shafts for accommodating overhung loads. Lubrication is positive at all speeds, in either direction of rotation and apart from an occasional oil check, no attention is necessary in service. Units are handed 'R' and 'L' with the suffix 'X' or 'Y' denoting position of slow speed shaft extension.

These are shown in the diagrams on the following page and references should be quoted when ordering.

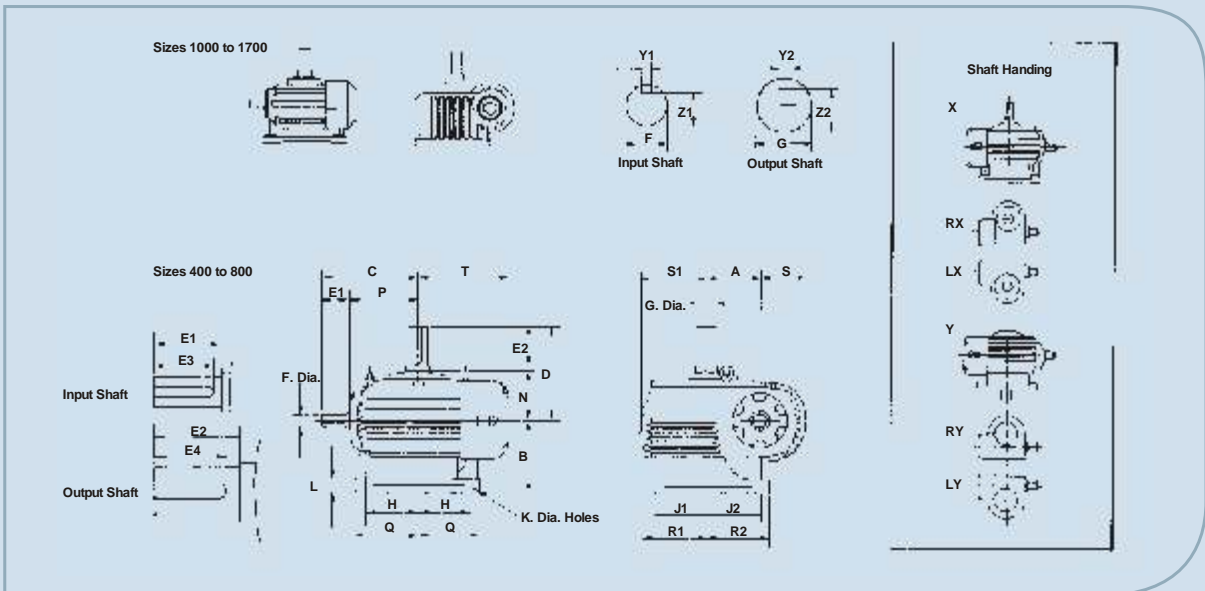

Principal Dimensions (mm)

SIZE	A	B	C	D	E1	E2	E3	E4	F	G	H	J1	J2	K
400	101.6	171.5	229	216	67	89	54	83	31.750 31.735	44.450 44.435	114.3	114.3	114.3	20.6
500	127.0	190.5	260	248	73	102	73	95	38.100 38.085	50.800 50.782	139.7	139.7	139.7	20.6
600	152.4	209.6	279	273	76	114	73	114	38.100 38.085	57.150 57.135	152.4	152.4	152.4	23.8
700	177.8	228.6	318	298	86	127	83	114	44.450 44.435	63.500 63.482	177.8	177.8	177.8	23.8
800	203.2	241.3	343	311	89	140	83	127	44.450 44.435	69.850 69.832	203.2	203.2	203.2	27.0
1000	254.0	279.4	425	375	121	152	89	143	57.150 57.135	82.550 82.527	260.4	260.4	235.0	31.8
1200	304.8	304.8	495	413	124	171	89	162	63.500 63.482	95.250 95.227	317.5	317.5	266.7	34.9
1400	355.6	330.2	572	483	149	191	146	210	76.200 76.182	114.300 114.277	355.6	355.6	304.8	41.3
1700	431.8	406.4	699	546	181	203	152	222	82.550 82.527	139.700 139.675	431.8	431.8	431.8	41.3



SIZE	L	N	P	Q	R1	R2	S	S1	T	Y1	Y2	Z1	Z2
400	32	121	159	140	140	140	111	152	222	7.976 7.925	11.176 11.125	34.47 34.24	47.73 47.50
500	32	133	184	165	165	165	124	178	254	9.576 9.525	12.751 12.700	40.72 40.49	53.98 53.75
600	38	140	200	184	184	184	133	197	270	9.576 9.525	15.926 15.875	40.72 40.49	61.75 61.52
700	38	151	229	210	210	210	143	222	305	11.176 11.125	15.926 15.875	47.73 47.50	68.10 67.87
800	44	159	251	238	238	238	149	254	327	11.176 11.125	19.101 19.050	47.73 47.50	75.03 74.80
1000	51	194	311	311	299	273	160	298	378	15.926 15.875	22.276 22.225	61.75 61.52	89.13 88.87
1200	57	216	368	368	356	305	177	356	441	15.926 15.875	25.476 25.400	68.10 67.87	103.20 102.95
1400	64	254	425	425	413	362	203	413	521	19.101 19.050	31.826 31.750	81.38 81.15	123.47 123.22
1700	76	305	514	502	502	502	241	502	629	22.276 22.225	38.202 38.100	89.13 88.90	150.04 149.73

STANDARD NOMINAL RATIOS													
400	5	7.5	10	12.5	15	20	25	30	-	40	50	60	70
500	5	7.5	10	-	15	20	25	30	35	40	50	60	70
600	5	7.5	10	-	15	20	25	30	35	40	50	60	70
700	5	7.5	10	-	15	20	25	30	35	40	50	60	70
800	5	7.5	10	-	15	20	25	30	-	40	50	60	70
1000	5	7.5	10	-	15	20	25	30	-	40	50	60	70
1200	5	7.5	10	12.5	15	20	25	30	35	40	50	60	70
1400	5	7.5	10	12.5	15	20	25	30	-	40	50	60	70
1700	-	-	10	-	15	20	25	30	-	40	50	60	70

Approximate Shipping Specification and Oil Capacities

Size	400	500	600	700	800	1000	1200	1400	1700
Net weight (kg)	77	109	145	200	254	465	690	970	1750
Gross weight (kg)	90	125	163	226	286	580	830	1250	2100
Volume Wheelshaft up	.12	.17	.21	.28	.44	1.0	1.4	1.9	2.8
packed (cu.m.)-wheelshaft down	.11	.15	.19	.25	.39	.9	1.3	1.75	2.6
Oil required at 1st filling (lit.)	4.0	5.7	6.3	10.2	12.5	22.7	37.4	68.5	105

As improvements in design are continually being made, this specification is not regarded as binding in detail, and dimensions are subject to alteration without notice.



GO - TYPE



Premium Speed Reducers are of substantial construction, combining rigidity with strength.

The worm is of high quality case-hardening steel, accurately generated, ground and super-finished. The worm wheel comprises a phosphor bronze centrifugally cast rim of substantial section welded to a rigid centre, which is pressed and keyed to the shaft.

Shafts are located on dual purpose bearings of ample capacity and having a substantial margin on output shafts for accommodating overhung loads. Lubrication is positive at all speeds, in either direction of rotation and apart from an occasional oil check, no attention is necessary in service.

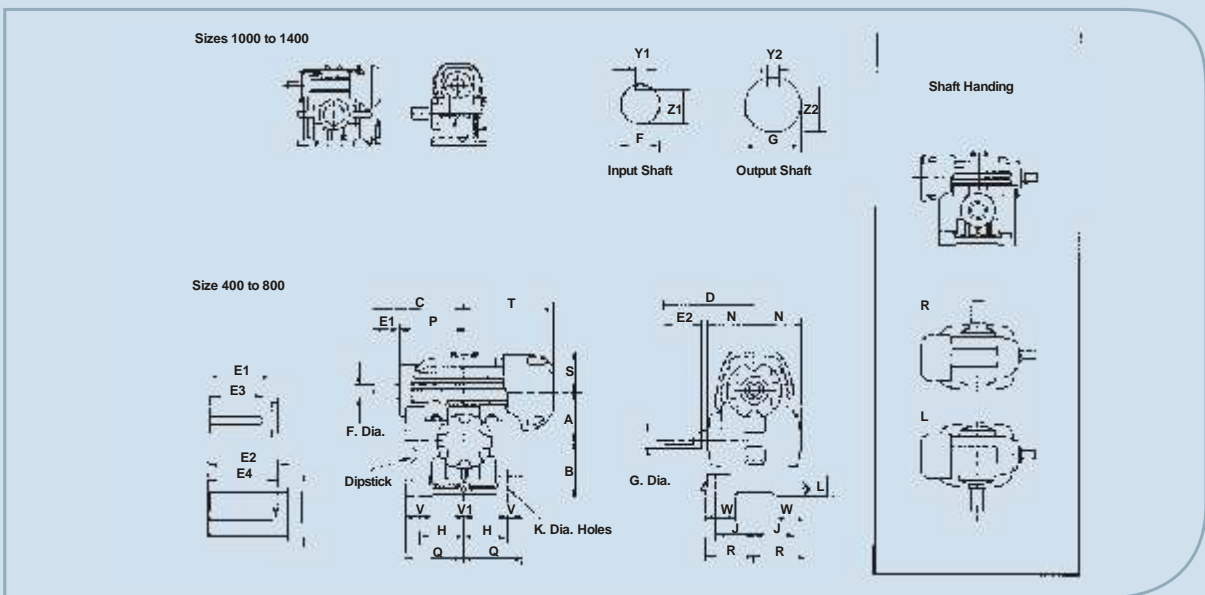

Principal Dimensions (mm)

SIZE	A	B	C	D	E1	E2	E3	E4	F	G	H	J	K
400	101.6	120.7	229	216	67	89	54	83	31.750 31.735	44.450 44.435	108.0	101.6	20.6
500	127.0	146.1	260	248	73	102	73	95	38.100 38.085	50.800 50.782	123.8	111.1	20.6
600	152.4	171.5	279	273	76	114	73	114	38.100 38.085	57.150 57.135	133.4	120.7	23.8
700	177.8	196.9	318	298	86	127	83	114	44.450 44.435	63.500 63.482	152.4	133.4	23.8
800	203.2	222.3	343	311	89	140	83	127	44.450 44.435	69.850 69.832	171.5	133.4	27.0
1000	254.0	273.1	425	375	121	152	89	143	57.150 57.135	82.550 82.527	215.9	165.1	31.8
1200	304.8	330.2	495	413	124	171	89	162	63.500 63.482	95.250 95.227	260.4	184.2	34.9
1400	355.6	381.0	572	483	149	191	146	210	76.200 76.182	114.300 114.277	298.5	215.9	41.3



SIZE	L	N	P	Q	R	S	T	V	V1	W	Y1	Y2	Z1	Z2
400	44	121	159	140	127	108	222	64	-	76	7.976 7.925	11.176 11.125	34.47 34.24	47.73 47.50
500	54	133	184	164	137	117	254	70	-	83	9.576 9.525	12.751 12.700	40.72 40.49	53.98 53.75
600	64	140	200	179	149	124	270	76	-	89	9.576 9.525	15.926 15.875	40.72 40.49	61.75 61.52
700	70	151	229	208	162	165	305	89	-	98	11.176 11.125	15.926 15.875	47.73 47.50	68.10 67.87
800	76	159	251	230	171	165	327	102	-	102	11.176 11.125	19.101 19.050	47.73 47.50	75.03 74.80
1000	51	194	311	298	200	191	378	127	64	200	15.926 15.875	22.276 22.225	61.75 61.52	89.13 88.87
1200	57	216	368	356	222	203	441	152	76	222	15.926 15.875	25.476 25.400	68.10 67.87	103.20 102.95
1400	64	254	425	413	260	229	521	178	89	260	19.101 19.050	31.826 31.750	81.38 81.15	123.47 123.22

STANDARD NOMINAL RATIOS													
400	5	7.5	10	12.5	15	20	25	30	-	40	50	60	70
500	5	7.5	10	-	15	20	25	30	35	40	50	60	70
600	5	7.5	10	-	15	20	25	30	35	40	50	60	70
700	5	7.5	10	-	15	20	25	30	35	40	50	60	70
800	5	7.5	10	-	15	20	25	30	-	40	50	60	70
1000	5	7.5	10	-	15	20	25	30	-	40	50	60	70
1200	5	7.5	10	12.5	15	20	25	30	35	40	50	60	70
1400	5	7.5	10	12.5	15	20	25	30	-	40	50	60	70
1700	-	-	10	-	15	20	25	30	-	40	50	60	70

Approximate Shipping Specification and Oil Capacities

Size	400	500	600	700	800	1000	1200	1400
Net weight (kg)	71	98	130	177	225	355	550	886
Gross weight (kg)	79	109	140	191	244	395	635	928
Volume packed (cu. m.)	.08	.12	.15	.21	.27	.48	.76	1.1
Oil required at 1st filling (lit)	3.0	4.3	6.3	9.1	11.4	15.9	22.7	36.4

As improvements in design are continually being made, this specification is not regarded as binding in detail, and dimensions are subject to alteration without notice.

**PREMIUM****Premium Energy Transmission Limited**

Head Office : P.B. No. 5, Chinchwad, Pune - 411 019, India.

Tel. : (91-20) 27475141/42/43/44, Fax : (91-20) 27450287, 27476601.

Website : www.premiumtransmission.com

Branch Offices :

Western Region :

Mumbai : Industry Manor, Appasaheb Marathe Marg, Prabhadevi, Mumbai - 400 025.

Tel. : (91-22) 24223747, 24365510, Fax : (91-22) 24377730.

Ahmedabad : "Jaldarshan", Ashram Road, Navrangpura, Ahmedabad - 380 009.

Tel. : (91-79) 26580428/0518/1861, Fax : (91-79) 26587783.

Nagpur : "Guman", Pandit Jawaharlal Nehru Marg, Sadar, P. B. No. 129, Nagpur - 440 001.

Tel. : (91-712) 2526588, 2524125, 2526038, Fax : (91-712) 2541142.

Northern Region :

New Delhi : Express Building Annexe, 9-10, Bahadur Shah Zafar Marg, New Delhi - 110 002.

Tel. : (91-11) 23730554 (8 lines), Fax : (91-11) 23359782.

Eastern Region :

Kolkata : Thapar House, 25, Brabourne Road, P. B. No. 702, Kolkata - 700 001.

Tel. : (91-33) 22423811, 22423780, 22423805, Fax : (91-33) 22424325.

Ranchi : Rani Kuthi, 82, Burdwan Compound, P.B. No. 139, Ranchi - 834 001.

Tel. : (91-651) 2562651, Fax : (91-651) 2562027.

Southern Region :

Chennai : "Wavoo Mansion", 6th Floor, New No. 48, (Old No. 39), Rajaji Salai, Chennai - 600 001.

Tel. : (91-44) 25240142, Fax : (91-44) 25224557.

Bangalore : 16/3, Ali Asker Road, P. B. No. 216, Bangalore - 560 052.

Tel. : (91-80) 22268773/2506, Fax : (91-80) 22253472.

Hyderabad : 6-2-47, A. C. Guards, 1st floor, P. B. No. 9, Hyderabad - 500 004.

Tel. : (91-40) 23314025, 23390544, 23316446, Fax : (91-40) 23318557.

Kochi : 39/5567, M. G. Road, Ernakulam, Kochi - 682 015.

Tel. : (91-484) 2359190, 2359372, Telefax : (91-484) 2359589.



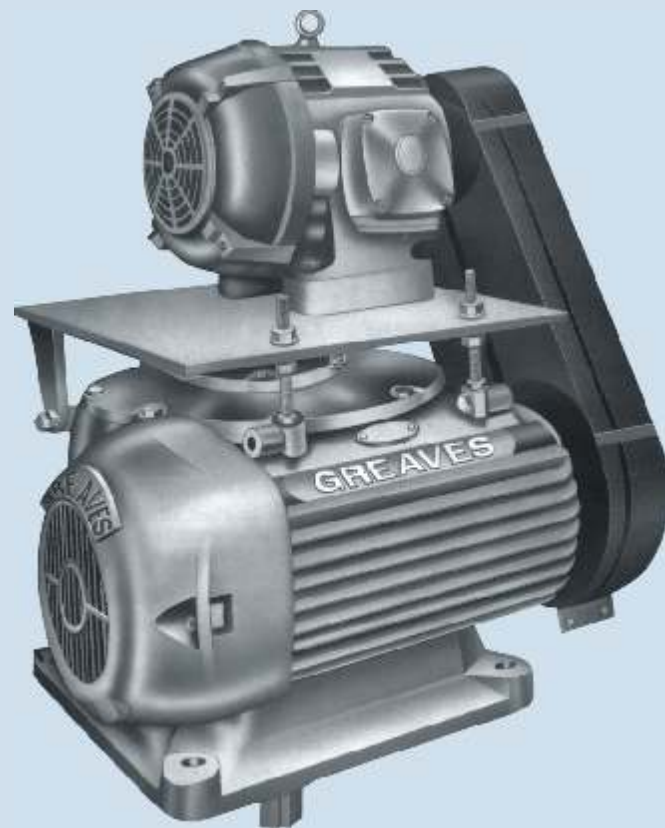

WORM GEARS STIRRER UNITS



PREMIUM ADAPTABLE SPEED REDUCERS

Premium Stirrer Units form the most comprehensive range available to industry. They are based on the standard V type single reduction Greaves Worm gear units the major component parts, including cases being common to both. Thus Greaves Stirrer Units offer standardised designs which give complete interchangeability and economy.

Versatility : Ten sizes cater for drives up to 150 HP. A wide range of ratios from 5/1 to 70/1 in each size, used in conjunction with the V belt drive, provide any required stirrer speed. Stirrer speed can be altered after plant installation by simply changing V belt ratio.

Construction : Substantial output shaft strength and bearing capacity permit rigid coupling of the stirrer shaft, using gear unit bearings for complete support of the stirrer shafts.

Larger taper roller bearings, greater bearing spans and extra large output shafts of high tensile steel characterise the heavy duty units, designed specifically for withstanding the higher loads imposed by the more arduous stirrer duties.

Compact Drive : The top mounted pivoted motor plate with belt tensioning device permits mounting of the motor directly above the gear unit. Thus, in addition to space saving, foundation costs are minimised and vessel design simplified. Time, expense and alignment errors on site can be reduced by having motor and V belt drive accurately fitted beforehand.

Selection

Information required for unit selection

As much information as possible should be given so that the correct size and type of gear unit can be selected for a given duty. Essential details are listed in the following

1. Horse-power or torque required at the stirrer shaft.
2. Type of prime mover and horse-power of prime mover.
3. Speed or range of speeds of stirrer shaft.
4. Total operating time per day with full details of loading cycles.
5. Nature of medium to be stirred i.e. constant or variable density.
6. Dimensions of the stirrer shaft, including length from the centre of the paddle to the top of the shaft, paddle diameter and shaft extension diameter.
7. Weight and thrust from paddle and direction of thrust.
8. Details of any abnormal operating conditions, e.g. ambient temperatures, humidity, etc.

Check torque capacity : Calculate the equivalent torque (t_e) on the stirrer shaft. $t_e = \text{Required output torque (t)} \times \text{service factor}$. Refer to Premium publication and select the size of unit which has an output torque capacity equal to or greater than equivalent torque.

Check shaft stress : Calculate load (p) on stirrer shaft.

$$p = [1000xt/0.75r] \dots \text{kN}$$

(assumed centre of pressure on paddle is $0.75r$, where r = paddle radius in mm)

Calculate bending moment (M) on stirrer shaft.

$$M = p.K/1000 \text{ kN.m}$$

"Refer to shaft stress limitation table, pages 4 and 5, and select the type of unit which has allowable bending moment equal to or greater than M "

Check bearing capacity : Determine bearing span (d) from page 6. Calculate equivalent load (p_e) on the stirrer shaft

$$p_e = p \times \text{service factor} \dots \text{kN}$$

Calculate the loads on bearings as shown below and check with capacities given on pages 4 and 5. Select the suitable type of unit.



STANDARD 'V' TYPE UNITS

Combined bearing Load = $pe (k + d)/d + f... kN$

where f = paddle thrust - paddle weight...kN

STANDARD DUTY STIRRER UNITS

Journal load = $pe (k + d)/d + f...kN$

Thrust load (f) = paddle thrust \pm paddle weight...kN

HEAVY DUTY STIRRER UNITS

Journal load = $pe.k/d...kN$

Thrust load (upward) = paddle thrust (upward) - paddle weight...kN

Thrust load (downward) = paddle weight \pm paddle thrust...kN

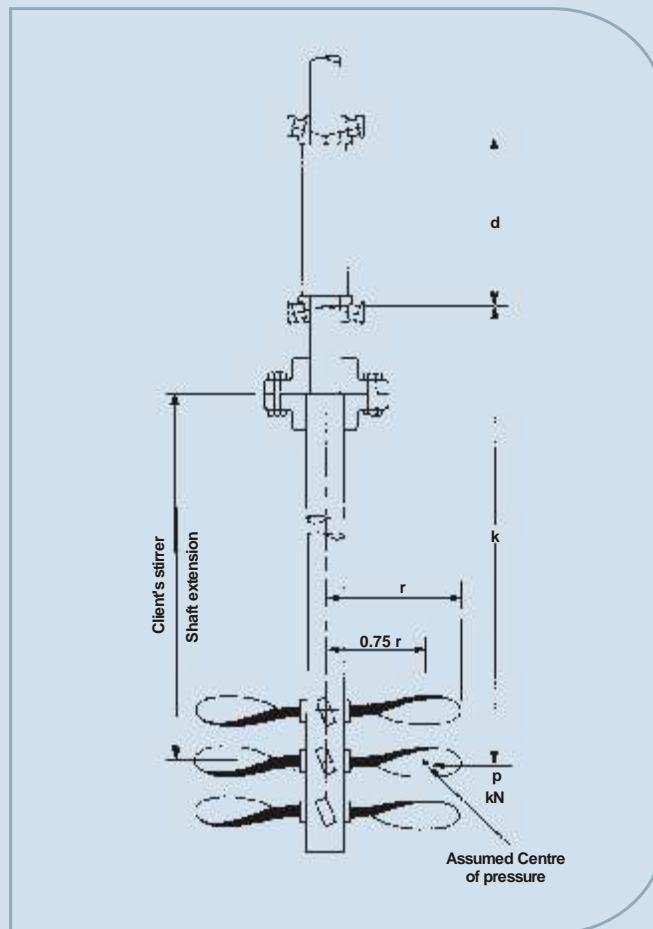

Service factors Load characteristics

Medium to be Stirred	Load Characteristics
Liquid or Semi-Liquid Variable density	Uniform Moderate shock

Prime Mover	Duration of Service hrs per day	Nature of Load on Gear Unit from Driven Machine	
		Uniform	Moderate
Electric Motor	under 3 to 10	0.8	1.0
		1.0	1.25



Example of selection

To select a Premium unit suitable for a stirrer drive, given the following information.

Power at stirrer shaft = 7.0 KW

Stirrer shaft speed = 40 r.p.m.

Running time is 12hrs continuous/day

Medium to be stirred is of variable density.

Stirrer shaft is to be supported entirely by the gear unit bearings as only a steady bearing is provided at the base of the vessel. Distance from centre of paddle to top of the stirrer shaft extension is 1016mm.

Outside diameter of paddle is 1780 mm

Combined thrust and weight from stirrer shaft is 6.675 kN downwards.

Step-I

Check torque capacity

service factor (see table below) is 1.25 Equivalent output Torque = $9.55 \times 7 \times 1.25/40$

= 1.671×1.25

= **2.089 kN.m**

Referring to Premium rating catalogues for an output speed of approximately 40 r.p.m., a V 700 worm reduction unit is suitable for this duty. A nominal ratio of 40/1 for an input speed of 1500 r.p.m., or 25/1 for 1000 r.p.m., will be suitable.

Step-II

Check load (p) on stirrer shaft

$$= 1000xt/0.75xr$$

$$= 1000 \times 1.671 / 0.75 \times 890$$

$$= \mathbf{2.503 \text{ kN}}$$

where k = stirrer extension + W

$$= 1016 + \mathbf{200.7}$$

$$= 1216.7 \text{ mm}$$

Bending Moment (M) = **p.k / 1000**

$$\text{(on Stirrer shaft)} = 2.503 \times 1216.7 / 1000$$

$$= 3.04 \text{ kN.m}$$

Since, the standard 'V' type unit has allowable bending moment less than the bending moment acting on the stirrer shaft, select standard duty stirrer unit.

$$\text{Now, } k = 1016 + W$$

$$= 1016 + \mathbf{203.7}$$

$$= \mathbf{1219.7 \text{ mm}}$$

Bending moment on stirrer shaft

$$= 2.503 \times 1219.7 / 1000$$

$$= \mathbf{3.05 \text{ kN.m}}$$

Step-III

Checking bearing capacity

Bearing span, $d = 189.48 \text{ mm}$

$$k = 1219.7 \text{ mm}$$

Equivalent load = (pe) = $p \times 1.25$

$$= 2.503 \times 1.25$$

$$= 3.128 \text{ kN}$$

Journal load = $pe (k + d) / d$

$$= 3.128 \times (1219.7 + 189.48) / 189.48$$

$$= \mathbf{23.263 \text{ kN}}$$

Thrust load on gearbox bearing = **6.675 kN**

Referring to catalogue, the loads imposed on the gearbox bearings are well within their capacity.



Bearing Limitation

Allowable Bending Moment at Bottom Bearing (kN)										
Output Speed (r.p.m.)	Taper Roller Bearings	STD V TYPE UNITS								
		SIZE OF UNIT								
		400	500	600	700	800	1000	1200	1400	1700
280		2.84	2.15	2.35	2.64	1.76	8.53	10.79	24.13	44.14
190		6.27	7.06	9.41	6.18	5.88	9.02	7.35	24.72	50.77
125		8.14	9.41	12.26	10.79	14.02	14.22	15.1	25.31	40.62
84		10.59	13.93	16	15	18.14	21.28	22.26	39.73	65.93
56		12.99	16.97	21.09	21.68	25.8	29.52	33.55	51.3	77.92
37		15.69	21.38	26.68	25.4	31.98	36.78	44.24	65.92	98.44
25		18.64	26	31.98	32.56	41.2	48.75	57.19	83.97	124.14
20 and below		21.19	28.94	35.7	35.02	45.32	54.54	64.55	94.26	128.53

Bearing Limitation

Allowable Bending Moment at Bottom Bearing (kN)										
Output Speed (r.p.m.)	Wider Taper Roller Bearings	STD DUTY STIRRER UNITS								
		SIZE OF UNIT								
			400	500	600	700	800	1000	1200	1400
280	thrust	6.57	8.24	10.4	10.98	13.53	19.42	23.54	36.98	43.75
	journal	10.59	14.02	15.89	17.75	20.2	29.03	37.18	56.9	77.5
190	thrust	9.41	12.16	15.89	15.2	17.95	22.66	24.72	41.79	47.18
	journal	13.14	17.65	21	20.7	24.52	32.57	39.43	63.17	84.36
125	thrust	11.67	15.1	19.32	19.81	24.91	28.35	32.76	47	59.35
	journal	15.3	20.6	24.52	25.11	26.88	38.55	48.07	70.24	100.06
84	thrust	14.12	19.13	23.44	24.32	29.82	35.31	40.22	59.74	70.14
	journal	17.76	24.56	28.25	29.23	35.9	45.32	56.31	83.87	113.79
56	thrust	16.57	22.36	28.15	30.21	36.69	43.36	50.13	71.51	85.74
	journal	20.79	28.74	33.84	35.9	43.55	54.54	68.76	99.08	135.37
37	thrust	19.71	26.68	33.84	35.9	43.55	54.54	68.76	99.08	135.37
	journal	24.32	34.13	40.22	41.4	51.6	64.35	81.71	117.72	158.9
25	thrust	22.85	31.58	39.73	42.08	52.38	61.9	72.98	103	122.62
	journal	28.05	39.43	46.2	48.85	60.72	76.61	95.94	138.32	186.39
20 and below	thrust	24.91	34.23	43.16	45.61	56.7	67.29	79.95	112.81	133.41
	journal	31	42.87	50.52	52.38	65.92	84.01	105.95	151.07	202.08



BEARING LIMITATION

Allowable Bending Moment at Bottom Bearing (kN)											
Output Speed (r.p.m.)		Heavy Duty Stirrer Units									
		Size Of Unit									
		400	500	600	700	800	1000	1200	1400	1700	
280	journal	10.10	13.34	14.81	16.48	18.54	28.15	36.20	55.42	64.25	
	thrust upward	6.57	8.14	10.40	10.98	13.04	19.42	23.54	36.98	57.14	
	thrust downward	15.20	18.14	21.09	26.97	33.15	38.16	39.14	54.05	60.41	
190	journal	12.85	17.16	20.01	19.42	22.76	37.47	38.26	61.90	97.36	
	thrust upward	9.41	12.16	15.79	15.20	17.95	22.66	24.72	41.79	67.40	
	thrust downward	19.42	23.74	28.05	33.55	40.80	43.85	43.94	59.64	83.19	
125	journal	14.91	19.91	23.44	23.774	29.62	37.57	46.80	68.08	99.86	
	thrust upward	11.67	15.10	19.32	19.81	24.91	28.35	32.76	47.00	68.36	
	thrust downward	23.05	28.25	33.35	40.80	51.11	52.00	52.68	69.45	94.60	
84	journal	17.26	24.23	27.17	27.86	34.23	44.34	55.13	82.01	122.33	
	thrust upward	14.12	19.13	23.44	24.32	29.72	35.31	40.22	59.74	89.02	
	thrust downward	26.88	33.94	39.33	48.07	59.44	63.07	63.47	83.77	114.22	
56	journal	20.40	28.15	32.86	34.72	41.88	53.75	67.88	97.31	141.45	
	thrust upward	16.57	22.36	28.15	30.21	36.69	43.36	50.13	71.51	103.58	
	thrust downward	31.39	39.43	46.40	57.58	70.73	74.26	75.63	99.96	136.45	
37	journal	23.74	33.45	39.14	39.92	50.03	63.66	80.93	116.24	169.20	
	thrust upward	19.71	26.68	33.84	35.21	43.36	51.30	61.11	86.23	123.91	
	thrust downward	36.78	46.50	54.93	66.80	82.89	87.60	89.85	117.23	158.50	
25	journal	27.56	38.84	45.12	47.48	59.25	75.83	95.45	137.14	199.67	
	thrust upward	22.76	31.58	39.63	42.08	52.38	61.90	72.98	103.00	148.03	
	thrust downward	42.38	54.05	63.76	78.08	96.82	98.88	105.06	137.14	185.26	
20 and below	journal	30.50	42.37	49.54	50.71	64.25	83.77	98.78	147.44	220.43	
	thrust upward	24.91	34.23	43.06	45.61	54.80	67.29	79.95	112.81	196.73	
	thrust downward	46.00	58.27	68.96	84.36	104.96	110.16	114.58	141.36	202.00	



SHAFT STRESS LIMITATION

Allowable Bending Moment at Bottom Bearing (kN.m)									
Output Speed (r.p.m.)	STD V TYPE UNITS SIZE OF UNIT								
	400	500	600	700	800	1000	1200	1400	1700
280	0.83	1.19	1.69	2.32	3.09	5.48	8.52	15.02	24.77
190	0.82	1.15	1.63	2.2	2.92	4.96	7.92	14.37	24.04
125	0.81	1.11	1.51	2.07	2.74	4.66	7.53	13.95	23.58
84	0.8	1.12	1.4	1.87	2.44	4.46	7.18	13.65	23.36
56	0.78	1.07	1.43	1.8	2.37	4.16	6.93	13.2	22.61
37	0.74	1	1.27	1.66	2.14	3.91	6.55	12.93	22.5
25	0.73	1.03	1.25	1.58	2.04	4.01	6.6	12.88	22.3
20 and below	0.77	1.06	1.23	1.28	1.85	3.96	6.53	12.88	22.41

Allowable Bending Moment at Bottom Bearing (kN.m)									
Output Speed (r.p.m.)	STD V TYPE UNITS SIZE OF UNIT								
	400	500	600	700	800	1000	1200	1400	1700
280	1.32	1.95	2.75	3.78	5	8.52	13.1	11.85	41.76
190	1.31	1.93	2.72	3.71	4.88	8.32	12.93	22.67	41.76
125	1.3	1.87	2.69	3.68	4.85	8.12	12.65	22.3	41.36
84	1.29	1.9	2.62	3.58	4.71	7.92	12.33	22.02	41.11
56	1.28	1.85	2.59	3.58	4.68	7.82	12.2	21.82	40.86
37	1.27	1.84	2.57	3.41	4.48	7.57	11.98	21.55	4.036
25	1.25	1.82	2.49	3.36	4.43	7.55	11.93	21.42	40.11
20 and below	1.27	1.83	2.49	3.24	4.33	7.67	11.88	21.42	40.11

Allowable Bending Moment at Bottom Bearing (kN.m)									
Output Speed (r.p.m.)	HEAVY DUTY STIRRER UNITS SIZE OF UNIT								
	400	500	600	700	800	1000	1200	1400	1700
280	3.43	5.65	6.3	9.59	12.18	14.8	18.81	30.15	47.16
190	3.48	5.6	6.45	9.56	12.01	15.1	19.21	30.89	48.41
125	3.43	5.5	6.33	9.54	12.21	15.49	19.68	31.64	49.58
84	3.43	5.6	6.23	9.41	12.01	16.29	20.65	33.39	52.5
56	3.41	5.5	6.23	9.56	12.08	16.22	21.18	34.38	54.18
37	3.36	5.5	6.2	9.19	11.71	16.57	21.55	34.88	55.12
25	3.33	5.48	6.08	9.19	11.76	16.76	22.05	35.63	56.2
20 and below	3.41	5.5	6.08	8.84	11.61	17.81	22.42	36.38	57.32



BENDING MOMENT & JOURNAL LOAD VALUES

Allowable Bending Moment at Bottom Bearing (kN.m)			
OUTPUT R.P.M.	V 900 STD	V 900 SDS	V 900 HDS
50	3.18	6.18	14.14
60	3.29	6.27	14.16
75	3.39	6.3	14.17

Allowable Journal & Thrust Loads (kn)						
OUTPUT R.P.M.	V 900 STD	V 900 SDS		V 900 HDS		
		Journal	Thrust	Journal	Thrust Upward	Thrust Downward
50	29.64	51.74	43.33	50.55	42.21	76.45
60	26.49	47.81	40.25	46.5	38.91	70.8
75	22.21	43.27	35.39	41.85	34.85	64.7

COMPARATIVE DETAILS (mm)

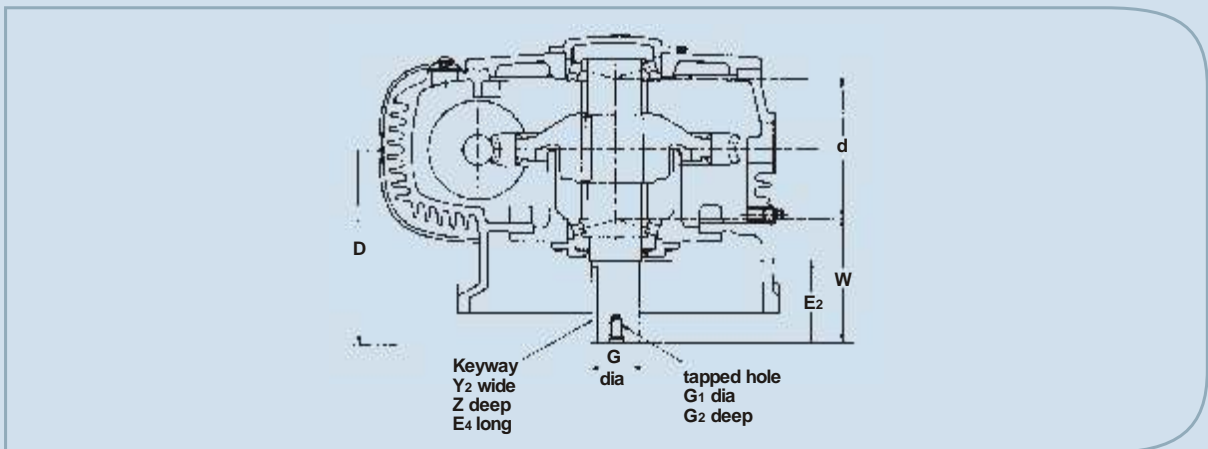

STANDARD V TYPE UNITS									
Taper roller bearings fitted on the output shaft.									
SIZE	400	500	600	700	800	1000	1200	1400	1700
d	151.4	170.7	177.3	195.6	204.2	255.5	285.5	329.2	401.8
W	150.4	162.3	184.4	200.7	209.0	246.0	270.0	318.0	345.2
G	44.45	50.80	57.15	63.50	69.85	82.55	95.25	114.30	139.70
Y ₂	11.11	12.70	15.88	15.88	19.05	22.23	25.40	31.75	38.10
Z	4.83	4.83	6.60	6.60	7.62	9.40	11.43	13.21	15.24
E ₂	88.9	101.6	114.3	127.0	139.7	152.4	171.5	190.5	203.2
E ₄	82.6	95.3	114.3	114.3	127.0	142.9	161.9	209.6	222.3
G ₁	M16	M16	M20	M20	M20	M20	M24	M24	M24
G ₂	36	36	40	40	40	40	50	50	50
D	215.9	247.7	273.1	298.5	311.2	374.7	412.8	482.6	546.1



RATINGS AT 1500 RPM INPUT SPEED

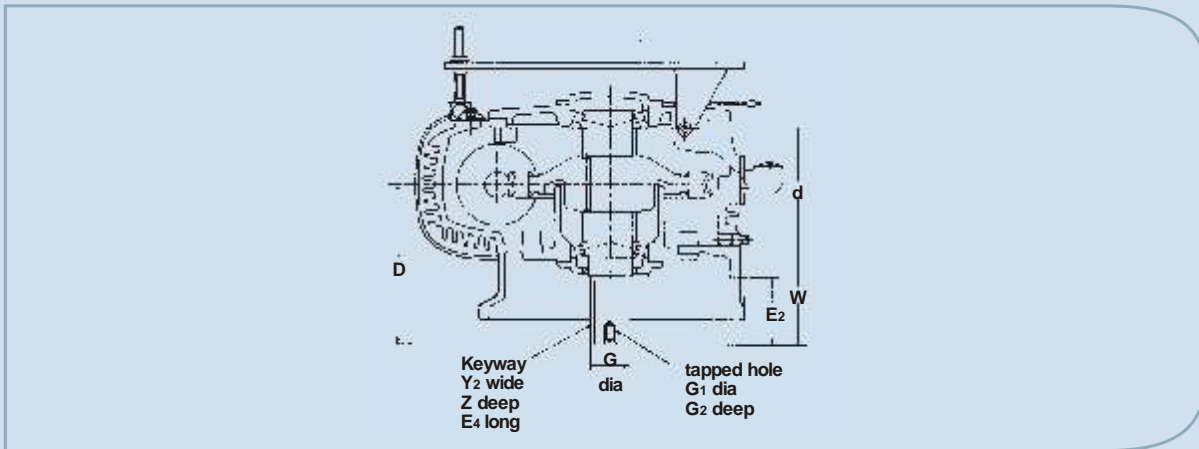

STANDARD DUTY STIRRER UNITS									
Wider taper roller bearings fitted. Output shaft made of high tensile steel									
SIZE	400	500	600	700	800	1000	1200	1400	1700
d	151.4	170.7	177.3	189.5	199.6	245.4	273.3	306.8	373.9
W	140.2	162.3	184.4	203.7	211.3	252.0	276.1	329.2	359.2
G	44.45	50.80	57.15	63.50	69.85	82.55	95.25	114.30	139.70
Y ₂	11.11	12.70	15.88	15.88	19.05	22.23	25.40	31.75	38.10
Z	4.83	4.83	6.60	6.60	7.62	9.40	11.43	13.21	15.24
E ₂	88.9	101.6	114.3	127.0	139.7	152.4	171.5	190.5	203.2
E ₄	82.6	95.3	114.3	114.3	127.0	142.9	161.9	209.6	222.3
G ₁	M16	M16	M20	M20	M20	M20	M24	M24	M24
G ₂	36	36	40	40	40	40	50	50	50
D	215.9	247.7	273.1	298.5	311.2	374.7	412.8	482.6	546.1

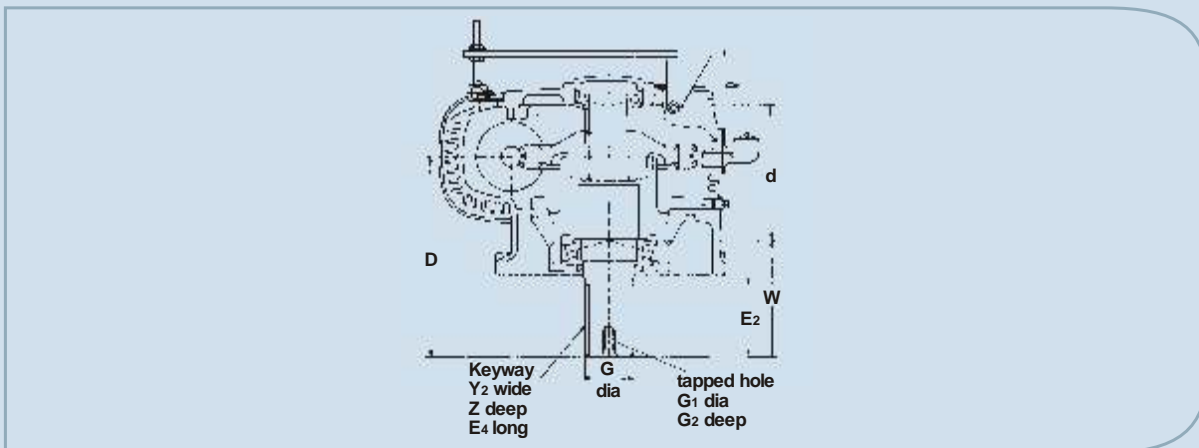

HEAVY DUTY STIRRER UNITS									
Extra large taper roller & wider taper roller bearings fitted. Larger bearing span, larger dia. shaft of high tensile materials									
SIZE	400	500	600	700	800	1000	1200	1400	1700
d	109.1	218.2	245.9	256.5	267.7	297.9	316.7	376.2	428.0
W	184.4	203.7	211.1	244.6	270.3	377.2	442.2	424.9	406.7
G	63.50	69.85	82.55	95.25	101.60	114.30	120.65	127.00	190.50
Y ₂	15.88	19.05	22.23	25.40	25.40	31.75	31.75	38.10	50.80
Z	6.60	7.62	9.40	11.43	11.43	13.21	13.21	13.21	20.83
E ₂	127.0	139.7	152.4	171.5	190.5	282.6	342.9	323.9	279.4
E ₄	127.0	127.0	139.7	158.8	177.8	209.6	209.6	209.6	304.8
G ₁	M20	M20	M20	M24	M24	M24	M24	M24	M36
G ₂	40	40	40	50	50	50	50	50	70
D	304.8	336.6	368.3	406.4	438.2	552.5	622.3	647.7	647.7



PRINCIPAL DIMENSIONS (MM)

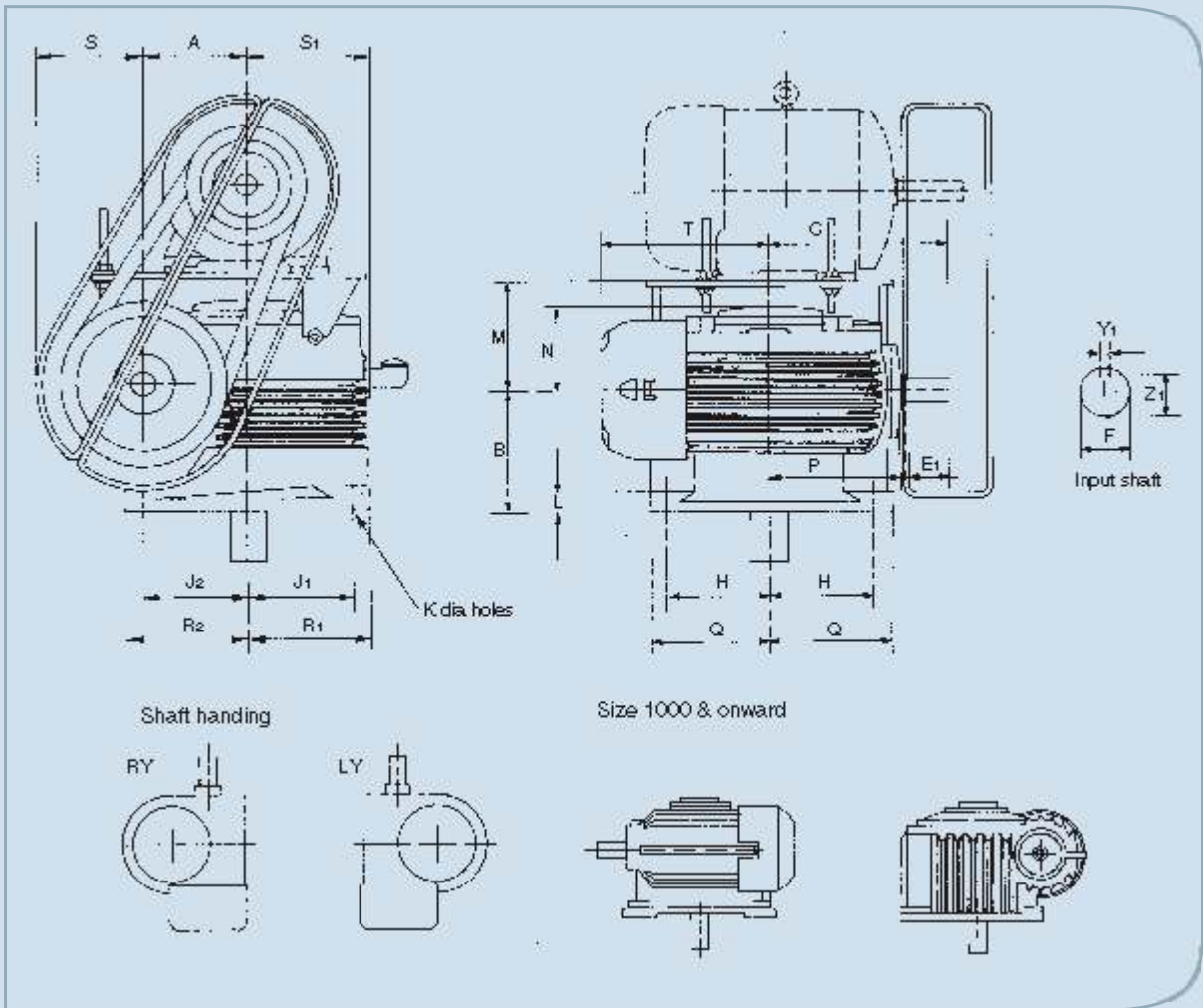

SIZE	A	B	C	E1	F	H	J1	J2	K	L	M
400	101.6	171.5	228.6	66.7	31.75	114.3	114.3	114.3	20.6	31.8	165
500	127.0	190.5	260.4	73.0	38.10	139.7	139.7	139.7	20.6	31.8	184
600	152.4	209.6	279.4	76.2	38.10	152.4	152.4	152.4	23.8	38.1	197
700	177.8	228.6	317.5	85.7	44.45	177.8	177.8	177.8	23.8	38.1	210
800	203.2	241.3	342.9	88.9	44.45	203.2	203.2	203.2	27.0	44.5	216
1000	254.0	279.4	425.5	120.7	57.15	260.4	260.4	235.0	31.8	50.8	229
1200	304.8	304.8	459.3	123.8	63.50	317.5	317.5	266.7	34.9	57.2	254
1400	355.6	330.2	571.5	149.2	76.20	355.6	355.6	304.8	41.3	63.5	330
1700	431.8	406.4	698.5	190.5	82.55	431.8	431.8	431.8	41.3	76.2	394

RATINGS AT 1500 RPM INPUT SPEED

SIZE	N	P	Q	R1	R2	S	S1	T	Y1	Z1
400	120	158.8	139.7	139.7	139.7	111	152.4	222	7.94	27.94
500	133	184.2	165.1	165.1	165.1	124	177.8	254	9.52	34.29
600	140	200.0	184.2	184.2	184.2	133	196.9	270	9.52	34.29
700	151	228.6	209.6	209.6	209.6	143	222.3	305	11.11	39.62
800	159	250.8	238.1	238.1	238.1	149	254.0	327	11.11	39.62
1000	194	311.2	311.2	298.5	273.1	160	298.5	378	15.88	50.55
1200	216	368.3	368.3	355.6	304.8	178	355.6	441	15.88	56.90
1400	254	425.5	425.5	412.8	362.0	203	412.8	521	19.05	68.58
1700	305	514.4	501.7	501.7	501.7	241	501.7	629	22.23	73.15

Shaft tolerances conform to B.S. 1916/1953H6, Keyways are to B.S. 46/1958.

The motor plate is available as additional equipment, duly slotted if required, to suit motor feet holes; full details of motor handing of the unit and preferably a layout drawing should be furnished.

As improvements in design are continually being made this specification is not to be regarded as binding in detail; dimensions are subject to alteration without notice.

EXACT STANDARD RATIOS

SIZE	5/1	7.5/1	10/1	12.5/1	15/1	20/1	25/1	30/1	35/1	40/1	50/1	60/1	70/1
400	4.83	7.5	9.67	12.75	14.5	19.5	25	30	-	40	50	60	70
500	5.0	7.4	9.75	-	14.5	19.5	24.5	30	35	40	50	60	70
600	4.88	7.6	9.75	-	14.67	20	24.5	30	35	40	50	60	70
700	5.0	7.5	9.75	-	14.67	19.5	24.5	30	35	40	50	60	70
800	5.0	7.5	9.75	-	14.67	19.5	24.5	29.5	-	40	50	60	70
1000	4.89	7.33	10.25	-	14.67	20.5	25.5	29.5	-	40	50	60	70
1200	4.9	7.43	9.8	12.25	14.67	19.67	24.5	29.5	35.5	40	50	60	70
1400	4.91	7.71	9.8	12.75	14.75	19.67	24.5	30.5	-	40	50	60	70
1700	-	-	10.17	-	15.25	19.67	24.67	29.5	-	40.5	50	60	70

SHIPPING SPECIFICATION & OIL CAPACITY

Description	Standard Duty										HeavyDuty							
	400	500	600	700	800	1000	1200	1400	1700	400	500	600	700	800	1000	1200	1400	1700
Size of Unit	400	500	600	700	800	1000	1200	1400	1700	400	500	600	700	800	1000	1200	1400	1700
Net Weight (kg)	77	109	145	200	254	465	690	970	1750	86	123	164	227	286	495	730	1020	1900
Gross Weight (kg)	90	125	163	226	286	580	830	1250	2100	109	143	186	264	327	625	890	1300	2350
Volume packed (cu.m.)	0.11	0.15	0.19	0.25	0.39	0.90	1.30	1.75	2.6	0.14	0.19	0.23	0.31	0.39	1.10	1.60	2.10	3.90
Oil required at 1st filling (Lit)	4.0	5.7	6.3	10.2	12.5	22.7	37.4	68.5	105	4.0	5.7	6.3	10.2	12.5	22.7	37.4	68.5	105

Weights and volumes are for gear units only. They do not include motors, motor plates, pulleys belts or guards.



PREMIUM

Premium Energy Transmission Limited

Head Office : P.B. No. 5, Chinchwad, Pune - 411 019, India.
Tel. : (91-20) 27475141/42/43/44, Fax : (91-20) 27450287, 27476601.
Website : www.premiumtransmission.com

Branch Offices :

Western Region :

Mumbai : Industry Manor, Appasaheb Marathe Marg, Prabhadevi, Mumbai - 400 025.
Tel. : (91-22) 24223747, 24365510, Fax : (91-22) 24377730.

Ahmedabad : "Jaldarshan", Ashram Road, Navrangpura, Ahmedabad - 380 009.
Tel. : (91-79) 26580428/0518/1861, Fax : (91-79) 26587783.

Nagpur : "Guman", Pandit Jawaharlal Nehru Marg, Sadar, P. B. No. 129, Nagpur - 440 001.
Tel. : (91-712) 2526588, 2524125, 2526038, Fax : (91-712) 2541142.

Northern Region :

New Delhi : Express Building Annexe, 9-10, Bahadur Shah Zafar Marg, New Delhi - 110 002.
Tel. : (91-11) 23730554 (8 lines), Fax : (91-11) 23359782.

Eastern Region :

Kolkata : Thapar House, 25, Brabourne Road, P. B. No. 702, Kolkata - 700 001.
Tel. : (91-33) 22423811, 22423780, 22423805, Fax : (91-33) 22424325.

Ranchi : Rani Kuthi, 82, Burdwan Compound, P.B. No. 139, Ranchi - 834 001.
Tel. : (91-651) 2562651, Fax : (91-651) 2562027.

Southern Region :

Chennai : "Wavoo Mansion", 6th Floor, New No. 48, (Old No. 39), Rajaji Salai, Chennai - 600 001.
Tel. : (91-44) 25240142, Fax : (91-44) 25224557.

Bangalore : 16/3, Ali Asker Road, P. B. No. 216, Bangalore - 560 052.
Tel. : (91-80) 22268773/2506, Fax : (91-80) 22253472.

Hyderabad : 6-2-47, A. C. Guards, 1st floor, P. B. No. 9, Hyderabad - 500 004.
Tel. : (91-40) 23314025, 23390544, 23316446, Fax : (91-40) 23318557.

Kochi : 39/5567, M. G. Road, Ernakulam, Kochi - 682 015.
Tel. : (91-484) 2359190, 2359372, Telefax : (91-484) 2359589.



Adaptable Shaft Mounted Gear Boxes

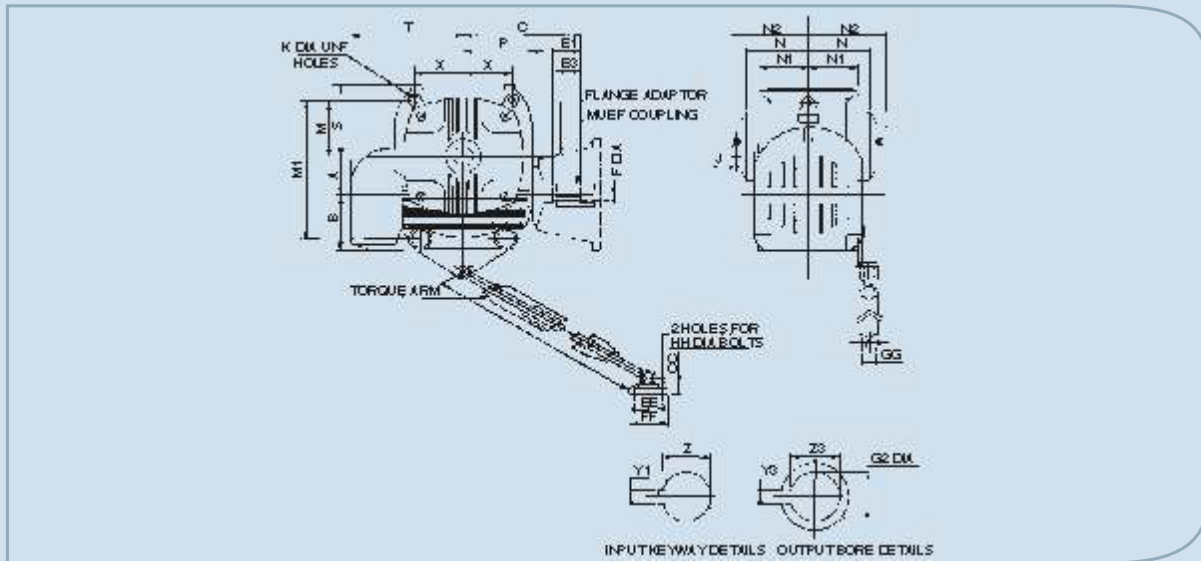

Torque-arm Dimensions (mm)

SIZE OF UNIT	AA	CC	EE	FF	GG	HH
162	356 - 508	20.6	51	70	25	8
200	483 - 835	25.4	57	83	32	10
237	483 - 835	25.4	57	83	32	10
287	483 - 835	25.4	57	83	32	10
337	610 - 762	30.2	70	102	38	13

Principal Dimensions (mm)

UNIT SIZE	A	B	C	E1	E3	F	G2	J	K	M	M1	N	N1	N2	P	S	T	X	Y	Z	Y3	Z3
162	41.3	50.8	110	41	38	15.875	20.021	4	6.4	47.6	130.2	49	37	56	71	57	89	39.7	4.826	17.96	6.015	23.0
						15.865	20.000												4.775	17.78	5.985	22.8
200	50.8	58.8	133	48	44	15.875	25.021	5	7.9	60.3	158.8	59	43	65	86	71	111	50.8	4.826	17.96	6.018	28.5
						15.865	25.000												4.775	17.78	7.962	28.3
237	60.3	68.3	159	57	54	19.050	30.021	5	9.5	71.4	187.3	68	51	73	98	84	130	60.3	4.826	21.16	8.018	33.5
						19.037	30.000												4.775	20.98	7.982	33.3
287	73.0	77.8	191	70	67	22.225	40.025	6	11.1	88.9	225.4	81	64	89	119	103	154	76.2	6.401	25.02	12.022	43.5
						22.212	40.000												6.350	24.82	11.979	43.3
337	85.7	90.8	219	83	79	25.400	50.030	6	12.7	100.0	260.4	96	76	105	133	116	175	85.7	6.401	28.19	14.022	54.0
						25.387	50.000												6.350	27.99	13.978	53.8

Note:- Torque - Arm, Muff Coupling And Flange Adaptor are Optional

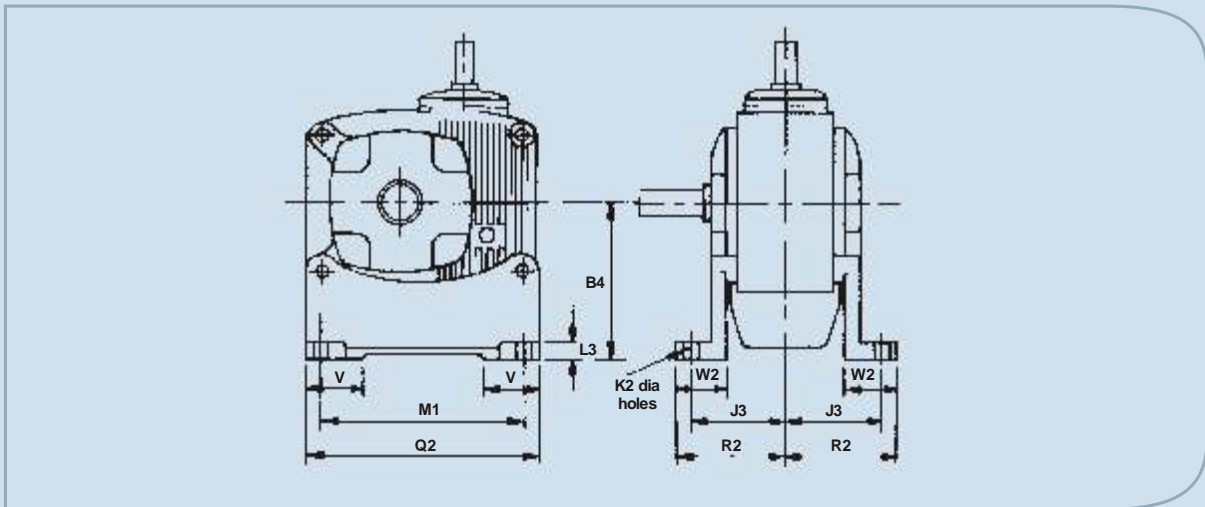

No. 1 Foot

SIZE	B1	B2	H	J	K1	K2	L	N1	Q	R	V	W	X
112	52.4	58.7	52.4	41.3	7.1	8.7	13	30	62	51	35	19	34.9
162	60.3	66.7	58.7	49.2	7.1	10.3	14	37	70	60	38	22	39.7
200	69.9	82.6	76.2	57.2	8.7	10.3	14	43	91	73	49	29	50.8
237	84.1	100.0	87.3	68.3	10.3	11.9	17	51	103	84	54	32	60.3
287	95.3	120.7	106.4	82.6	11.9	13.5	21	64	124	100	60	35	76.2
337	109.5	134.9	119.1	96.8	13.5	15.1	22	76	138	116	67	38	85.7

No. 2 Foot

B3	H	J1	J2	K1	K2	L	M	M1	Q1	R1	V1	W1	X
54.0	52.4	57.2	79.4	7.1	8.7	13	41.3	104.8	64	159	37	41	34.9
63.5	58.7	65.1	100.0	7.1	10.3	14	47.6	130.2	71	191	40	46	39.7
69.9	76.2	82.6	120.7	8.7	10.3	14	60.3	158.8	89	229	51	52	50.8
82.6	87.3	95.3	139.7	10.3	11.9	17	71.4	187.3	103	267	57	59	60.3
98.4	106.4	114.3	161.9	11.9	13.5	21	88.9	225.4	124	311	65	65	76.2
114.3	119.1	128.6	188.9	13.5	15.1	22	100.0	260.4	138	356	73	73	85.7

No. 3 Foot

SIZE	B4	J3	L	M1	O2	R2	V	W2
112	93.7	55.6	10	104.8	124	65	35	29
162	101.6	65.1	11	130.2	152	76	38	32
200	127.0	71.4	14	158.8	191	89	49	38
237	146.1	84.1	17	187.3	219	100	54	41
287	173.0	101.6	19	225.4	260	119	60	48
337	193.7	115.9	21	260.4	298	133	67	49

As improvements in design are continually being made, this specification is not to be regarded as binding in detail, and dimensions are subject to alteration without notice.

Lubrication

The diagrams illustrate typical arrangements of mounting and give details of the respective positions of Breather, Oil Level and Drain Plugs. Normally units are despatched with plugs fitted as shown in the first diagram, which shows the basic "space" mounting. Where units are required to operate in other positions, it is necessary to reposition the Breather Plug as indicated. The Breather Plug should always be kept clean and free from blockage.

RECOMMENDED LUBRICANT ISO VG320

Brand	Grade
Bharat Petroleum	Cabol 320 or Amocam 320
Castrol	Alpha ZN320
Gulf	Harmony 320
Hindustan Petroleum	Enklo 320
Indian Oil	Servomesh SP 320 or Servosystem 320
Veedol	Avalon 320

A Oil filler-breather B Oil Drain C Oil Level

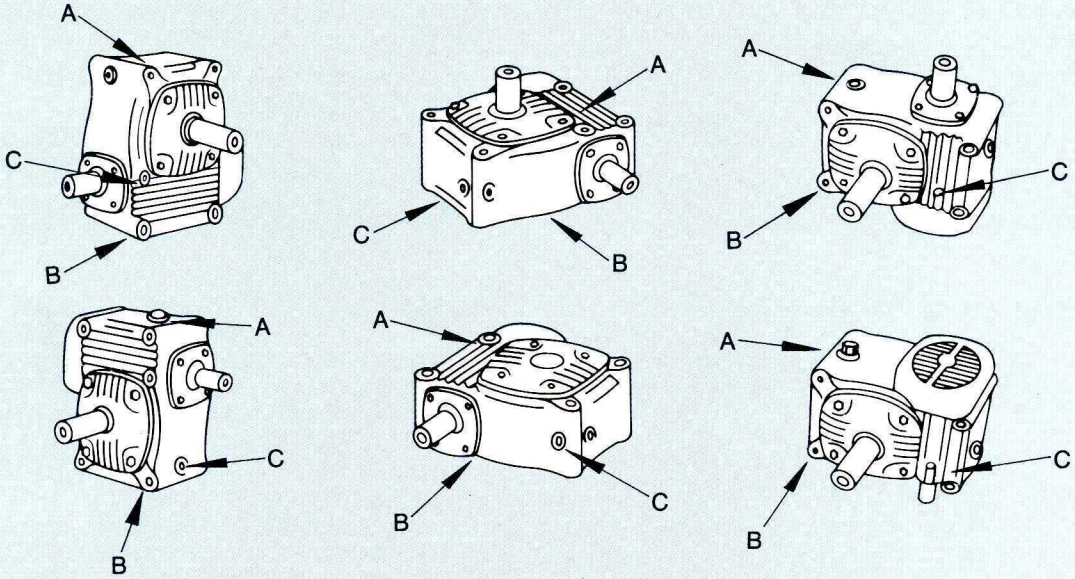

DRG. NO.

IF IN DOUBT, ASK!

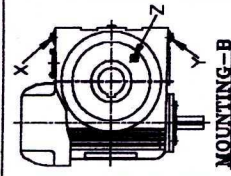
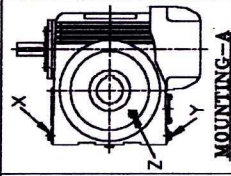
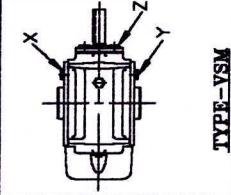
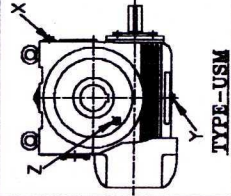
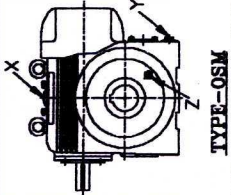
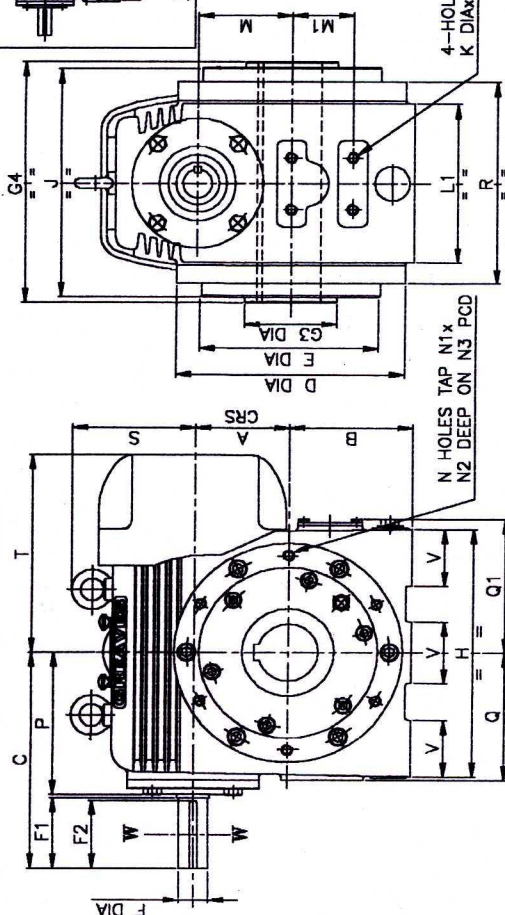

STANDARD MOUNTING POSITIONS
 X - OIL FILLER-BREATHER
 Y - OIL DRAIN
 Z - OIL LEVEL PLUG

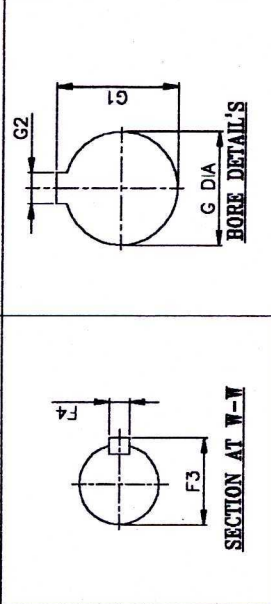

SIZE OF UNIT	L1	M	M1	N	N1 DIA	N2 DIA	N3 PCD	P	Q	Q1	R	S	T	V	G2 MM	G3	G4	H	J	K DIA	K1	MM	L
SM 400	101.6	133	228.6	248	193.68	31.75	66.68	54	34.27	7.86	65.030	69.60	15.022	100	266.7	279	254	M12	20	63.5			
SM 500	127	152	260	286	193.68	31.75	73	73	40.48	6.35	70.030	75.10	20.026	110	285.8	330	289.9	M12	20	63.5			
SM 600	152.4	171.5	279	330	215.87	38.10	76	73	40.48	6.35	75.030	80.10	20.026	120	304.8	362	285.8	M12	20	73.03			
SM 700	177.8	200	317.5	387	247.65	44.45	86	82.6	47.72	11.07	80.030	85.40	21.974	130	320.7	413	308	M12	20	76.2			
SM 800	203.2	225.5	343	438	263.52	44.45	89	82.6	47.72	11.07	80.035	85.40	24.974	140	339.7	457	320.7	M12	20	76.2			
SM 1000	254	273	425.5	546	317.46	57.15	120.65	89	61.52	15.88	100.035	106.60	26.026	160	393.7	546	374.7	M16	27	76.2			
SM 1200	304.8	319	495	638	342.90	63.50	123.83	89	68.10	15.88	110.000	116.40	27.974	170	431.8	638	412.8	M16	27	89			

SIZE OF UNIT	L1	M	M1	N	N1 DIA	N2 DIA	N3 PCD	P	Q	Q1	R	S	T	V	V1
SM 400	174.62	111.12	57.15	152.4	M12	20	219.07	158.75	143.66	149.22	222.25	142.87	222.25	63.5	69.85
SM 500	184.15	139.7	69.85	203.2	M12	20	257.17	184.15	169.06	176.2	238.12	252.4	254	69.85	69.85
SM 600	190.5	139.7	92.07	152.4	M12	20	247.65	200.02	184.94	190.5	250.82	158.75	269.87	76.2	82.55
SM 700	212.73	155.6	117.5	152.4	M12	20	279.4	228.6	215.9	219	273.05	171.45	304.8	76.2	82.55
SM 800	219.07	155.6	127	152.4	M12	20	317.5	250.82	234.15	247.65	279.4	174.63	327.03	76.2	82.55
SM 1000	254	190.5	152.4	203.2	M16	27	381	311.15	280.19	285.75	323.85	195.26	377.82	101.6	101.6
SM 1200	292	228.6	177.8	203.2	M16	27	406.4	368.3	334.16	339.73	362	214.31	441.32	101.6	101.6

NOTE:-
 ALL IMPROVEMENTS IN DESIGN ARE CONTINUALLY BEING MADE. THIS SPECIFICATION IS NOT TO BE REGARDED AS BINDING IN DETAIL. DIMENSION ARE SUBJECT TO ALTERATION WITHOUT NOTICE.
 DIMENSIONS FROM CAST SURFACES WITHIN ±3MM

SHAFT MOUNTED WORM REDUCTION UNITS (SM TYPE)

ALTERATIONS

DEGREE OF FINISH
 Δ - ROUGH MACHINE
 ΔΔ - SMOOTH MACHINE
 G - GROUND
 sf - SPIRITFACE
 √ - CLA

SCALE: 1:1

DRAWN SNEHA-1
 CHECKED
 PASSED

FILE

DATE 13/05/03

DRG. NO. : A-040407

PREMIUM

LIFT GEAR BOX

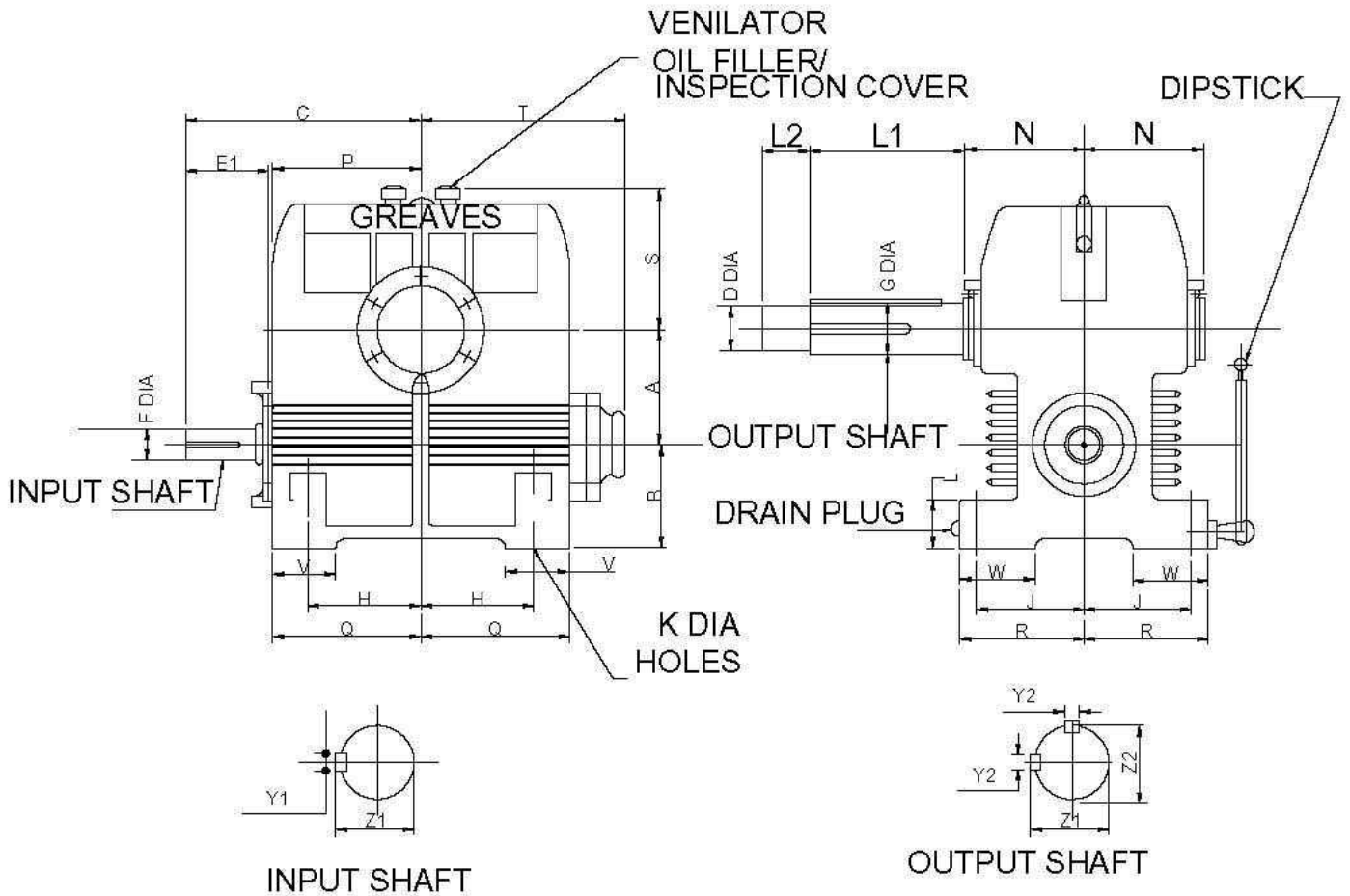

SIZE OF UNIT	A	B	C	E1	F	G	H	J	K	L	N	P	Q	R	S	T	V	W	Y1	Y2	Z1	Z2
SLA 500	127	114.3	260	73	38.100 38.085	57.190 57.180	123.8	111.1	20.6	64	133	184	164	137	169	225	70	83	9.576 9.525	15.928 15.875	40.72 40.49	61.75 61.52
SLA 600	162.4	127.0	279	76	38.100 38.085	63.600 63.482	133.4	120.7	23.6	64	140	208	179	149	184	249	78	89	9.576 9.525	15.926 15.875	40.72 40.49	68.10 67.87
SLA 700	177.8	146.1	318	86	44.490 44.435	69.890 69.832	162.4	133.4	23.8	70	161	237	208	182	210	281	89	98	11.176 11.125	19.101 19.060	47.73 47.50	75.03 74.80
SLA 800	203.2	146.1	343	89	44.490 44.435	74.813 74.800	171.5	133.4	27.0	78	169	280	230	171	235	300	102	102	11.176 11.125	19.101 19.060	47.73 47.50	79.01 79.08

NOTE:- A) DIMENSIONS L1, L2, & D ARE TO CUSTOMERS SPECIFICATION AND FULL DETAILS SHOULD BE SUBMITTED WITH ENQUIRES FOR LIFT UNIS.
 B) FOR BIGGER SIZES GEAR BOXES REFER GREAVES LIMITED.
 C) 'P' DIMENSIONS ARE OVER SCREW HEADS.

GREAVES DUPLEX WORM GEARBOX

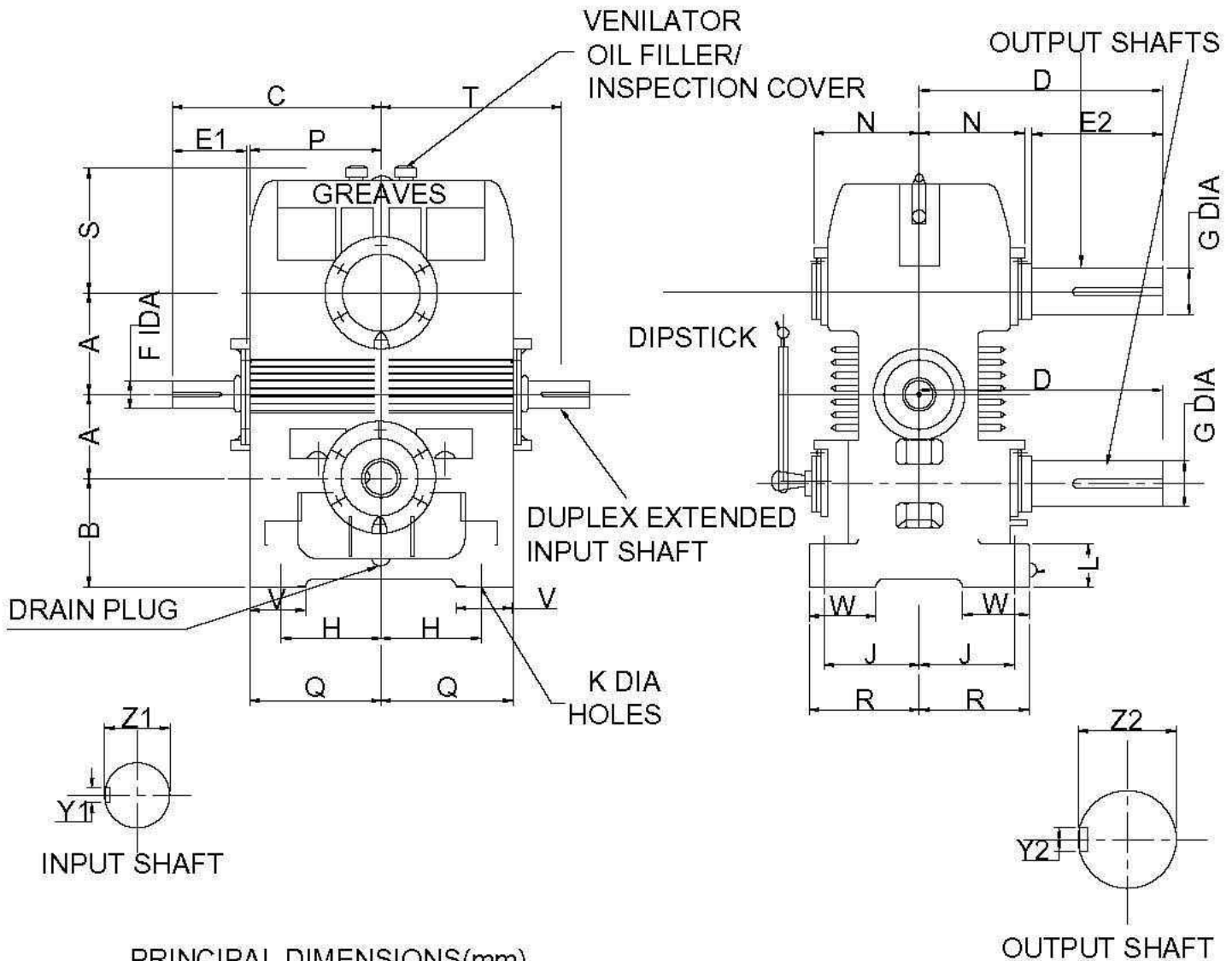

PRINCIPAL DIMENSIONS(mm)

SIZE OF UNIT	A	B	C	D	E1	E2	F	G	H	J	K	L	N	P	Q
DX 400	101.6	120.7	229	216	67	89	31.750 31.735	44.450 44.435	106.0	101.6	20.6	44	121	159	140
DX 500	127	114.3	260	248	73	102	38.100 38.085	50.800 50.782	123.8	111.1	20.6	54	133	184	164
DX 600	152.4	171.5	279	273	76	114	38.100 38.085	57.150 57.135	133.4	120.7	23.8	64	140	200	179
DX 700	177.8	196.9	318	298	86	127	44.450 44.435	63.500 63.482	152.4	133.4	23.8	70	151	229	208
DX 800	203.2	222.3	343	311	89	140	44.450 44.435	69.850 69.832	171.5	133.4	27.0	78	159	251	230

SIZE OF UNIT	R	S	V	W	Y1	Y2	Z1	Z2
DX 400	127	137	64	76	7.976 7.925	11.176 11.125	34.47 34.24	47.73 47.50
DX 500	137	159	70	83	9.576 9.525	12.751 12.700	40.72 40.49	53.98 53.75
DX 600	149	184	76	89	9.576 9.525	15.926 15.875	40.72 40.49	81.75 81.52
DX 700	162	210	89	98	11.178 11.125	15.926 15.875	47.73 47.50	88.10 87.87
DX 800	171	235	102	102	11.178 11.125	19.101 19.050	47.73 47.50	75.03 74.80

NOTE: - A) DIMENSIONS E2 & D CAN BE SUPPLIED TO CUSTOMERS SPECIFICATION AND FULL DETAILS SHOULD BE SUBMITTED WITH ENQUIRY FOR LIFT UNITS.
 B) FOR BIGGER SIZES GEAR BOXES REFER GREAVES LIMITED.
 C) 'P' DIMENSIONS ARE OVER SCREW HEADS.



PREMIUM

Greaves

Double Reduction Speed Reducers

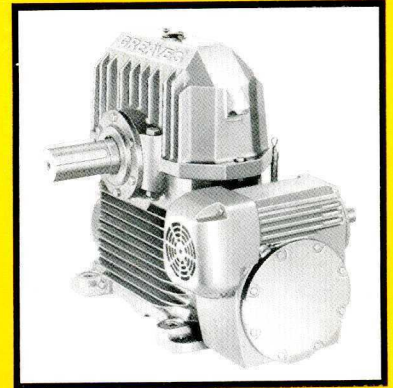

Greaves Double Reduction Speed Reducers are two stage worm reduction units. A specially designed primary worm reduction unit is integrally mounted on a standard single reduction Greaves worm reducer which forms the second stage. The composite units provide the most compact and rigid arrangement for large reduction of speed necessary for slow moving machinery. A wide range of ratios upto 4900:1 is available.

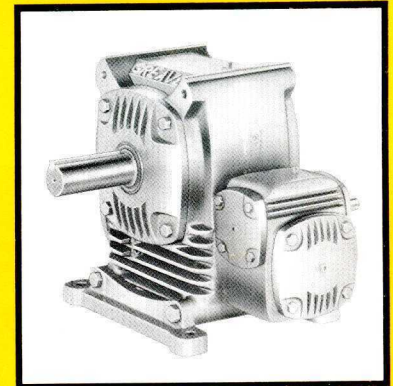

The wormshafts are made of high quality case hardening steel, accurately generated, ground and superfinished. The wormwheels comprise of phosphor bronze centrifugally cast rims of substantial sections welded to rigid centres. Considerable flexibility of shaft layout is permissible with all types of Double Reduction units. The dimension drawing for each series shows the different shaft handing arrangements and the appropriate reference should always be quoted when ordering.

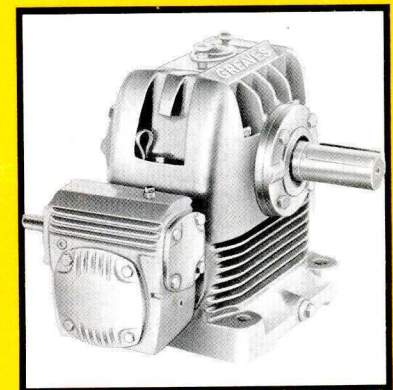

GREAVES Double Reduction Adaptable Speed Reducers

TYPE AUD

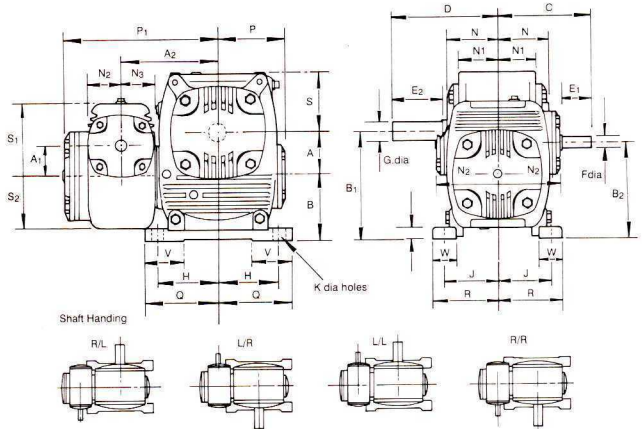

Care should be taken when using "L/L" or "R/R" to ensure that the motor, where direct coupled, will clear the slow-speed shaft.

TYPE AOD

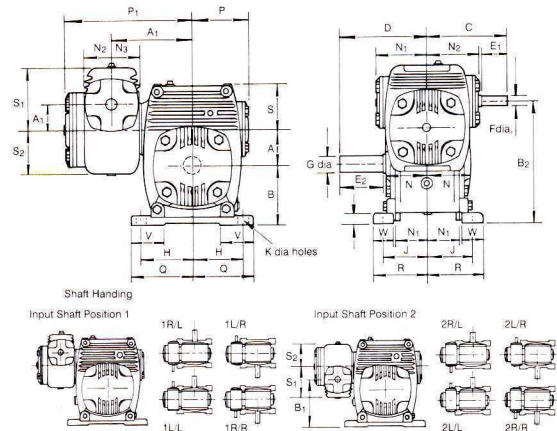

Care should be taken when using "1L/L", "1R/R", "2L/L" or "2R/R" to ensure that the motor, where direct coupled, will clear the slow-speed shaft.

TYPE AVD

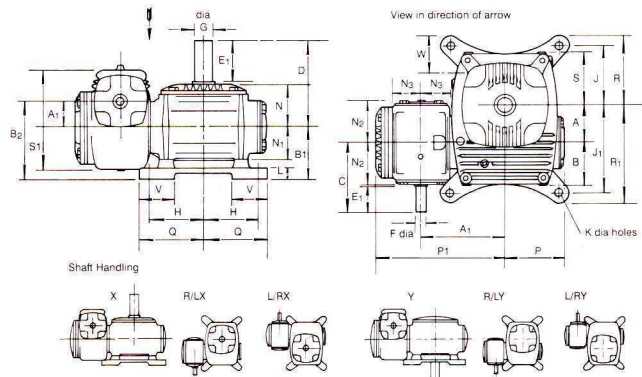

Designations with suffix "X" e.g. "R/LX", denote units with slow-speed shafts extended vertically upward. Suffix "Y", e.g. "R/LY" refers to units with slow-speed extended vertically downward.
 Note: The slow speed shaft extension, when downward, is the same dimensionally as the upward projection from the high-speed shaft centre-line. Dimensions D, E2 and N apply to both arrangements.

Principal Dimensions (mm)

AUD																													
Size	A	A ₁	A ₂	B	B ₁	B ₂	C	D	E ₁	E ₂	F	G	H	J	K	L	N	N ₁	N ₂	N ₃	P	P ₁	Q	R	S	S ₁	S ₂	V	W
162	41.3	28.6	92.1	60.3	101.6	88.9	90	98	29	48	11.113 11.102	19.050 19.037	58.7	49.2	10.3	11	49	37	59	32	68	148	70	60	60	70	51	38	22
200	50.8	28.6	106.4	69.9	120.7	98.4	90	117	29	57	11.113 11.102	25.400 25.387	76.2	57.2	10.3	14	59	43	59	32	84	162	91	73	74	70	51	49	29
237	60.3	41.3	133.4	84.1	144.5	125.4	110	140	41	70	15.875 15.865	28.575 28.562	87.3	68.3	11.9	17	68	51	68	46	98	208	103	84	87	92	67	54	32
287	73.0	41.3	152.4	95.3	168.3	136.5	110	168	41	83	15.875 15.865	31.750 31.735	106.4	82.6	13.5	19	81	64	68	46	119	227	124	100	106	92	67	60	35
337	85.7	41.3	168.3	109.5	195.3	150.8	110	200	41	98	15.875 15.865	38.100 38.085	119.1	96.8	15.1	21	98	76	68	46	133	243	138	116	119	92	67	67	38

AOD																													
Size	A	A ₁	A ₂	B	B ₁	B ₂	C	D	E ₁	E ₂	F	G	H	J	K	L	N	N ₁	N ₂	N ₃	P	P ₁	Q	R	S	S ₁	S ₂	V	W
162	41.3	28.6	92.1	66.7	79.4	136.5	90	98	29	48	11.113 11.102	19.050 19.037	58.7	49.2	10.3	11.1	49	37	59	32	68	148	70	60	54	70	51	38	22
200	50.8	28.6	106.4	82.6	104.8	161.9	90	117	29	57	11.113 11.102	25.400 25.387	76.2	57.2	10.3	14.3	59	43	59	32	84	162	91	73	62	70	51	49	29
237	60.3	41.3	133.4	100.00	119.1	201.6	110	140	41	70	15.875 15.865	28.575 28.562	87.3	68.3	11.9	17.5	68	51	68	46	98	208	103	84	71	92	67	54	32
287	73.0	41.3	152.4	120.7	152.4	235.0	110	168	41	83	15.875 15.865	31.750 31.735	106.4	82.6	13.5	19.1	81	64	68	46	119	227	124	100	81	92	67	60	35
337	85.7	41.3	168.3	134.9	179.4	261.9	110	200	41	98	15.875 15.865	38.100 38.085	119.1	96.8	15.1	20.6	98	76	68	46	133	243	138	116	94	92	67	67	38

AVD																															
Size	A	A ₁	A ₂	B	B ₁	B ₂	C	D	E ₁	E ₂	F	G	H	J	J ₁	K	L	N	N ₁	N ₂	N ₃	P	P ₁	Q	R	R ₁	S	S ₁	S ₂	V	W
162	41.3	28.6	92.1	54.0	63.5	92.1	90	98	29	48	11.113 11.102	19.050 19.037	58.7	65.1	100.0	10.3	14	49	37	59	32	68	148	71	78	113	60	70	51	40	46
200	50.8	28.6	106.4	61.9	69.9	98.4	90	117	29	57	11.113 11.102	25.400 25.387	76.2	82.6	120.7	10.3	14	59	43	59	32	84	162	89	95	133	75	70	51	51	52
237	60.3	41.3	133.4	71.4	82.6	123.8	110	140	41	70	15.875 15.865	28.575 28.562	87.3	95.3	139.7	11.9	17	68	51	68	46	98	208	103	111	156	87	92	67	57	59
287	73.0	41.3	152.4	81.0	98.4	139.7	110	168	41	83	15.875 15.865	31.750 31.735	106.4	114.3	161.9	13.5	21	81	64	68	46	119	227	124	132	179	106	92	67	65	65
337	85.7	41.3	168.3	93.7	114.3	155.6	110	200	41	98	15.875 15.865	38.100 38.085	119.1	128.6	188.9	15.1	22	98	76	68	46	133	243	138	148	208	119	92	67	73	73

GREAVES Double Reduction solid foot Speed Reducers

UD

UD
1000-1700

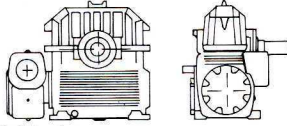

Shaft Handing

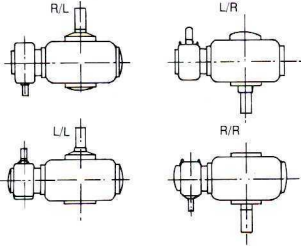

UD
400-800

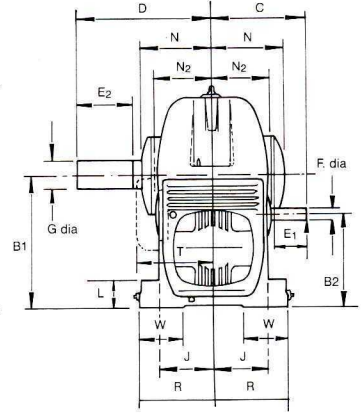
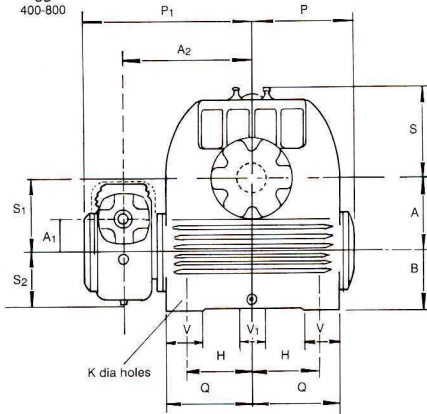

OD

OD
1000-1400

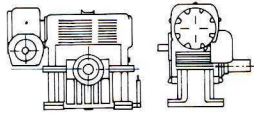

Shaft Handing

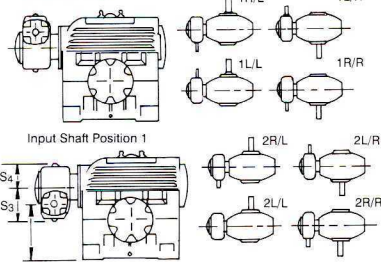

Input Shaft Position 2

OD
400-800

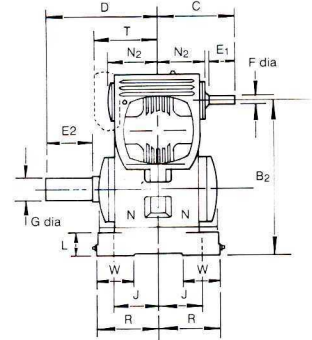
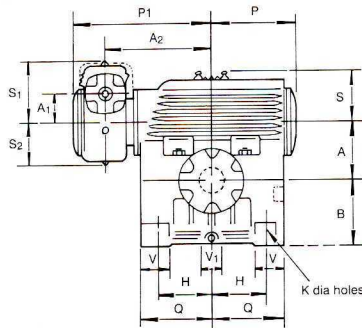

VD

VD
1000-1700

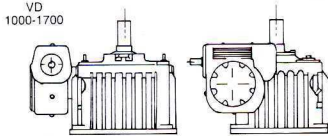

Shaft Handing

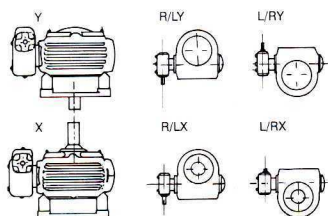

VD
400-800

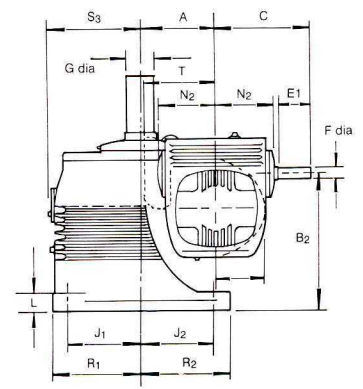
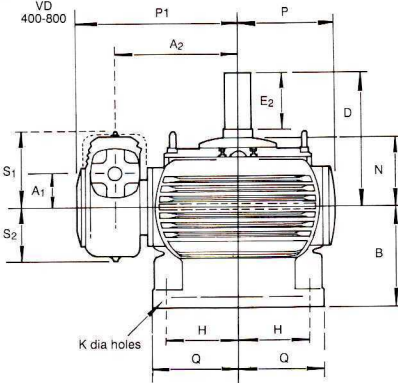

Designations with suffix "X" e.g. "R/LX", denote units with slow-speed shafts extended vertically upward. Suffix "Y", e.g. "R/LY" refers to units with slow-speed extended vertically downward.
Note : The slow speed shaft extension, when downward, is the same dimensionally as the upward projection from the high-speed shaft centre-line. Dimensions D, E2 and N apply to both arrangements.

Principal Dimensions (mm)

UD																													
Size	A	A1	A2	B	B1	B2	C	D	E1	E2	F	G	H	J	K	L	N	N2	P	P1	Q	R	S	S1	S2	T	V	V1	W
400	101.6	50.8	214.3	108.0	209.6	158.8	133	216	48	89	15.87	44.45	108.0	101.6	20.6	44	121	84	159	276	140	127	137	116	78	-	64	-	76
500	127.0	60.3	247.7	114.3	214.3	174.6	159	248	57	102	19.05	50.80	123.8	111.1	20.6	54	133	100	184	319	164	137	159	132	90	-	70	-	83
600	152.4	73.0	265.1	127.0	279.4	200.0	191	273	70	114	22.2	57.15	133.4	120.7	23.8	64	140	119	200	346	179	149	184	156	110	-	76	-	89
700	177.8	85.7	304.8	146.1	323.9	231.8	219	298	83	127	25.4	63.50	152.4	133.4	23.8	70	151	135	229	400	208	162	210	184	124	-	89	-	98
800	203.2	101.6	336.6	146.1	349.3	247.7	229	311	67	140	31.75	69.85	171.5	133.4	27.0	76	159	162	251	441	230	171	235	203	137	222	102	-	102
1000	254.0	127.0	419.1	171.5	425.5	298.5	260	375	73	152	38.1	82.55	215.9	165.1	31.8	51	194	178	311	549	298	200	292	241	165	254	127	64	200
1200	304.8	152.4	479.4	190.5	495.3	342.9	279	413	76	171	38.1	95.25	260.4	184.2	34.9	57	216	191	368	625	356	222	343	284	186	270	152	76	222
1400	355.6	177.8	552.5	215.9	571.5	393.7	318	483	86	191	44.4	114.30	298.5	215.9	41.3	64	254	222	425	702	413	260	394	314	232	305	178	89	260
1700	431.8	203.2	660.4	254.0	685.8	457.2	343	546	89	203	44.4	139.70	381.0	254.0	41.3	76	305	250	514	822	502	298	489	349	254	327	191	127	298

OD																															
Size	A	A1	A2	B	B1	B2	C	D	E1	E2	F	G	H	J	K	L	N	N2	P	P1	Q	R	S	S1	S2	S3	S4	T	V	V1	W
400	101.6	50.8	214.3	120.7	171.5	273.1	133	216	48	89	15.87	44.45	108.0	101.6	20.6	44	121	84	159	276	140	127	108	116	78	116	78	-	64	-	76
500	127.0	60.3	247.7	146.1	212.7	333.4	139	248	57	102	19.05	50.80	123.8	111.1	20.6	54	133	100	184	319	164	137	117	132	90	132	90	-	70	-	83
600	152.4	73.0	265.1	171.5	250.8	396.9	191	273	70	114	22.2	57.15	133.4	120.7	23.8	64	140	119	200	346	179	149	124	156	110	156	110	-	76	-	89
700	177.8	85.7	304.8	196.9	288.9	460.4	219	296	83	127	25.4	63.50	152.4	133.4	23.8	70	151	135	229	400	208	162	165	184	124	184	124	-	89	-	98
800	203.2	101.6	336.6	222.3	223.8	527.1	229	311	67	140	31.75	69.85	171.5	133.4	27.0	76	159	162	251	441	230	171	165	203	137	203	137	222	102	-	102
1000	254.0	127.0	419.1	273.1	400.1	654.1	260	375	73	152	38.1	82.55	215.9	165.1	31.8	51	194	178	311	549	298	200	191	241	165	241	171	254	127	64	200
1200	304.8	152.4	479.4	330.2	482.6	787.4	279	413	76	171	38.1	95.25	260.4	184.2	34.9	57	216	191	368	625	356	222	203	284	186	284	186	270	152	76	222
1400	355.6	177.8	552.5	381.0	558.8	914.4	343	483	86	191	44.4	114.30	298.5	215.9	41.3	64	254	222	425	702	413	260	229	314	232	314	232	305	178	89	260

VD																												
Size	A	A1	A2	B	B2	C	D	E1	E2	F	G	H	J1	J2	K	L	N	N2	P	P1	Q	R1	R2	S	S1	S2	S3	T
400	101.6	50.8	214.3	171.5	222.3	133	216	48	89	15.87	44.45	114.3	114.3	114.3	20.6	32	121	84	159	276	140	140	140	98.4	116	78	152	-
500	127.0	60.3	247.7	190.5	250.8	159	248	57	102	19.05	50.8	139.7	139.7	139.7	20.6	32	133	100	184	319	165	165	165	111	132	90	178	-
600	152.4	73.0	265.1	209.6	282.6	191	273	70	114	22.2	57.15	152.4	152.4	152.4	23.8	38	140	119	200	346	184	184	184	120	155.8	110	197	-
700	177.8	85.7	304.8	228.6	314.3	219	298	83	127	25.4	63.50	177.8	177.8	177.8	23.8	38	151	135	229	400	210	210	210	130	184	124	222	-
800	203.2	101.6	336.6	241.3	342.9	229	311	67	140	31.75	69.85	203.2	203.2	203.2	27.0	44	159	162	251	449	238	238	238	136.5	203	137	254	222
1000	254.0	127.0	419.1	279.4	406.4	260	375	73	152	38.1	82.55	260.4	260.4	235.0	31.8	51	194	178	311	549	311	299	273	173	241	165	298	254
1200	304.8	152.4	479.4	304.8	457.2	279	413	76	171	38.1	95.25	317.5	317.5	266.7	34.9	57	216	191	368	625	368	356	305	150.5	284	186	356	270
1400	355.6	177.8	552.5	330.2	508.0	318	483	86	191	44.4	114.30	355.6	355.6	304.8	41.3	64	254	222	425	702	425	413	362	216	314	232	413	305
1700	431.8	203.2	660.4	406.4	609.6	343	546	89	203	44.4	139.70	431.8	431.8	431.8	41.3	76	305	250	514	822	502	502	502	254	349	254	502	327

GREAVES Double Reduction Adaptable Speed Reducers

LUBRICATION

The primary and secondary units of double reduction Greaves ADAPTABLE units must be filled separately, with recommended oil. Plugs have been provided on all sides of the unit. The plugs at extreme top serve as oil filler and breather, the bottom plugs are for drain and the plug in between is to be used for oil level checking. Over-filling should be avoided; this might result in oil leakage and over-heating.

RECOMMENDED LUBRICANT

ISO VG320

Brand	Grade
Bharat Petroleum	Cabol 320 or Amocam 320
Castrol	Alpha ZN 320
Gulf	Harmony 320
Hindustan Petroleum	Enklo 320
Indian Oil	Servomesh SP320 or Servosystem 320
Veedol	Aavalon 320

Approximate Shipping Specification and Oil Capacities

Size	162	200	237	287	337
Net Weight (kg)	10	14.5	24.5	37	51
Gross Weight (kg)	15	20	32	48	66
Volume packed (Cu.m.)	0.034	0.040	0.057	0.079	.125
Oil required Primary Unit at 1 st filling (litres)	0.14	0.14	0.28	0.28	0.28
Final Unit	0.28	0.28	0.57	0.85	1.42

A supply of oil is not included in any unit

As improvements in design are continually being made, this specification is not to be regarded as binding in detail and dimensions are subject to alteration without notice.

Standard Shaft Dimensions (mm)

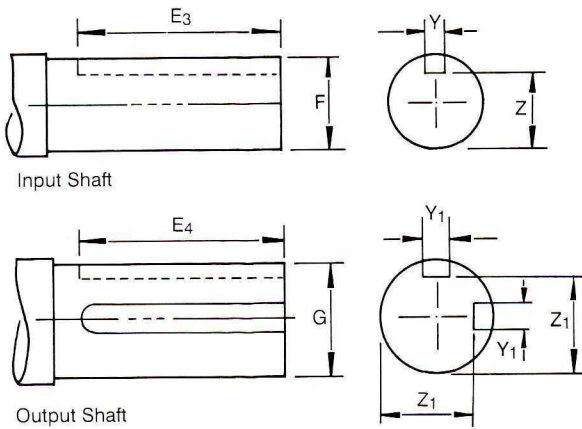

	Input Shaft					Output Shaft			
	Size	F	E2	Y	Z	G	E4	Y1	Z1
UD	400	15.875	44	4.78	13.16	44.450	83	11.13	39.73
		15.865		4.75	13.00			11.10	39.57
UD	500	19.050	54	4.78	16.33	50.800	95	12.70	45.97
		19.037		4.75	16.18			12.67	45.82
UD	600	22.225	67	6.35	18.62	57.150	114	15.88	50.55
		22.212		6.32	18.47			15.85	50.39
OD	700	25.400	79	6.35	21.79	63.500	114	15.88	56.90
		25.387		6.32	21.64			15.85	56.74
VD	800	31.750	54	7.95	28.04	69.850	127	19.05	62.26
		31.735		7.92	27.89			19.02	62.10
VD	1000	38.100	73	9.53	34.29	82.550	143	22.23	73.15
		38.085		9.50	34.14			22.20	73.00
VD	1200	38.100	73	9.53	34.29	95.250	162	25.40	84.05
		38.085		9.50	34.14			25.37	83.90
VD	1400	44.450	83	11.13	39.73	114.300	210	31.75	101.14
		44.435		11.10	39.57			31.70	100.99
VD	1700	44.450	83	11.13	39.73	139.700	222	38.10	124.49
		44.435		11.10	39.57			38.05	124.33

Direction of Rotation

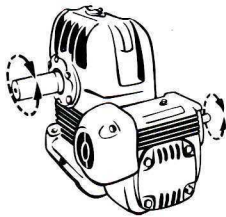

UD - shaft handing "R/L"

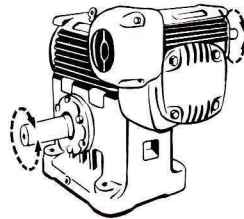

OD - shaft handing "1R/L"

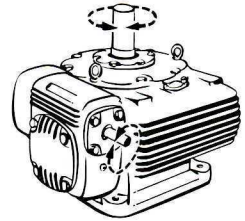

VD - shaft handing "R/LX"

Shipping Specifications and Oil Capacity (approx.)

SIZE OF UNIT	NET WEIGHT (KG.)			GROSS WEIGHT (KG.)			VOLUME PACKED (CU.M)			OIL CAPACITY (LITRE)			
	UD	OD	VD	UD	OD	VD	UD	OD	VD	PRIMARY UNIT	SECONDARY UNIT		
											UD	OD	VD
400	73	87	76	88	108	95	.14	.14	.17	0.6	2.8	2.3	4.0
500	116	122	129	145	151	162	.20	.20	.24	0.6	4.0	2.8	5.7
600	166	155	177	204	193	222	.30	.28	.32	1.1	5.7	4.0	6.3
700	218	228	253	273	285	319	.38	.43	.49	1.7	9.1	5.7	10.2
800	268	280	305	324	336	382	.45	.48	.54	2.8	11.4	9.1	12.5
1000	419	450	540	550	591	690	.74	.79	.88	4.0	17.5	6.8	22.7
1200	634	682	790	775	864	982	1.02	1.16	1.13	5.7	23.0	7.9	37.4
1400	945	1046	1096	1172	1318	1415	1.47	1.59	1.67	9.1	37.0	18.2	68.5
1700	1650	-	1800	1875	-	2100	2.35	-	2.60	11.5	55.0	-	90.0

GREAVES COOLING TOWER UNITS

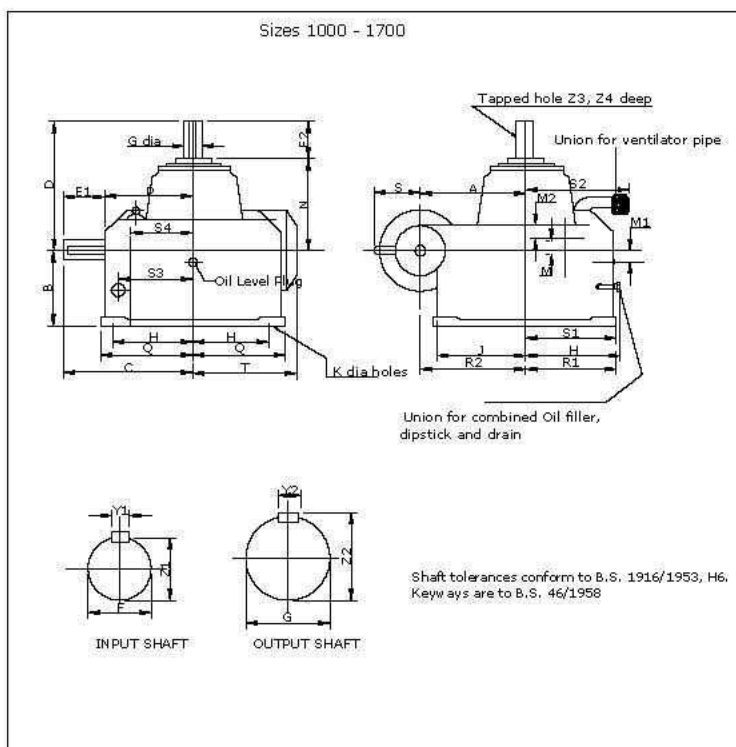
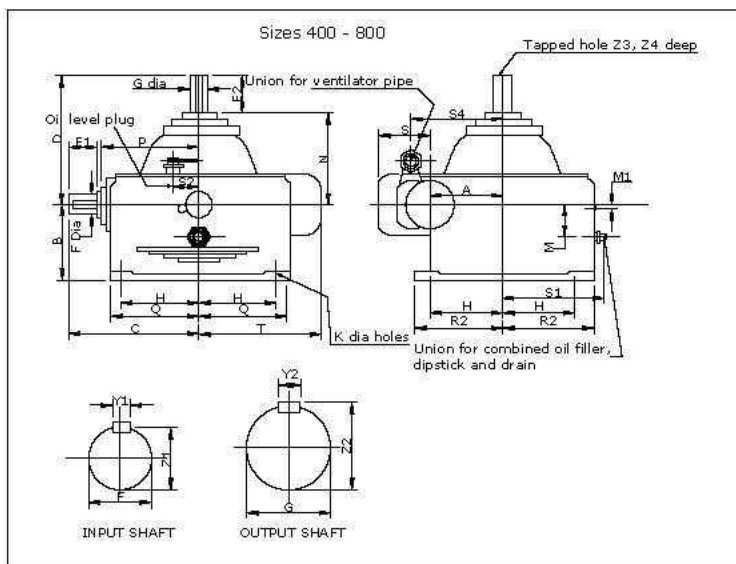

Unit size	400	500	600	700	800	1000	1200	1400	1700
A	101.6	127.0	152.4	177.8	203.2	254.0	304.8	355.6	431.8
B	171.5	190.5	209.6	228.6	241.3	279.4	304.8	330.2	406.4
*C	229	260	279	318	343	425	495	572	679
*D	343	381	419	432	470	540	597	730	800
*E1	67	73	76	86	89	121	124	149	181
*E2	89	102	114	127	140	152	171	191	203
*E3	54	73	73	83	83	89	89	146	152
*E4	83	95	114	114	127	143	162	210	222
F	31.750	38.100	38.100	44.450	44.450	57.150	63.500	76.200	82.550
G	31.735	38.085	38.085	44.435	44.435	57.135	63.482	76.182	82.527
H	44.435	50.800	57.150	63.500	69.850	82.550	95.250	114.300	139.700
I	44.435	50.782	57.135	63.482	69.832	82.527	95.227	114.277	139.675
J	114.3	139.7	152.4	177.8	203.2	260.4	317.5	355.6	431.8
K	--	--	--	--	--	235.0	266.7	304.8	431.8
L	20.6	20.6	23.8	23.8	27.0	31.8	34.9	41.3	41.3
M	65.0	77.7	82.6	90.4	96.8	117.6	130.3	152.4	196.9
M1	16.0	16.0	19.1	20.6	22.4	28.7	33.3	35.1	28.7
M2	131.8	144.5	150.9	155.7	163.6	171.5	190.5	209.6	215.9
N	254	279	305	305	330	387	425	540	559
P	159	184	200	229	251	311	368	425	514
Q	140	165	184	210	238	311	368	425	502
R1	140	165	184	210	238	299	356	413	502
R2	140	165	184	210	238	273	305	362	502
S	111	124	133	143	149	160	177	203	241
S1	173	198	217	243	268	337	387	419	521
S2	75	75	75	75	75	248	292	315	419
S3	--	--	--	--	--	266.7	317.5	349.3	381
S4	147.6	174.8	196.9	227.1	251.0	193.8	228.6	254.9	366.6
T	222	254	270	305	327	378	441	521	629
Y1	7.976	9.576	9.576	11.176	11.176	15.926	15.926	19.101	22.276
Y2	7.925	9.525	9.525	11.125	11.125	15.875	15.875	19.050	22.225
Z1	11.176	12.751	15.926	15.926	19.101	22.276	25.476	31.826	38.202
Z2	11.125	12.700	15.875	15.875	19.050	22.225	25.400	31.750	38.100
Z3	34.47	40.72	40.72	47.73	47.73	61.75	68.10	81.38	89.13
Z4	47.73	53.98	61.75	68.10	75.03	89.13	103.20	123.47	150.04
Z5	47.50	53.75	61.52	67.87	74.80	88.87	102.95	123.22	149.73
Z6	M16	M16	M20	M20	M20	M20	M24	M24	M24
Z7	36	36	40	40	40	40	50	50	50

Approximate Shipping Specification and Oil Capacities

Size	400	500	600	700	800	1000	1200	1400	1700
Net weight (kg)	93	132	175	230	280	505	721	1145	1950
Gross weight (kg)	109	152	198	274	348	685	947	1465	2300
Volume packed (cu.m)	0.14	0.20	0.24	0.32	0.48	1.44	1.72	2.28	3.05
Oil required at 1 st filling (lit.)	4.4	6.3	6.9	11.2	13.8	25	41	75	110

Type BS double reduction

BSU
10-14

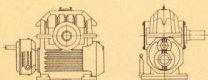

BSU
400-800

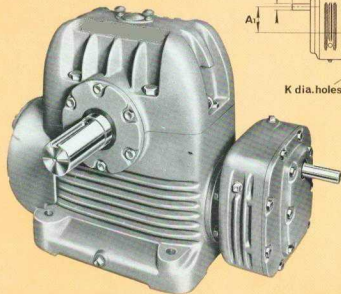
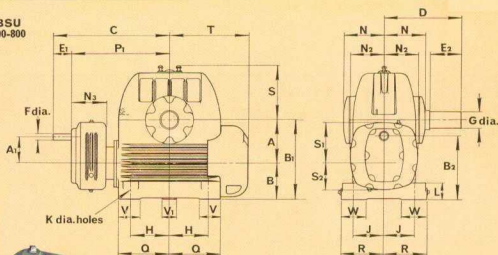

Shaft Handling

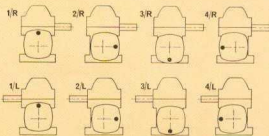

BSU

Size	A	A ₁	B	B ₁	B ₂	C	D	E ₁	E ₂	F	G	H	J	K	L	N	N ₂	N ₃	P ₁	Q	R	S	S ₁	S ₂	T	V	V ₁	W
400	4	3	4½	8½	7½	13½	8½	2½	3½	¾	1½	4½	4	1½	1½	4½	4½	4½	11½	5½	5	5½	5	3½	8½	2½	—	3
500	5	3	4½	9½	7½	14½	9½	2½	4	¾	2	4½	4½	1½	2½	5½	4½	4½	12½	6-7½	5½	6½	5	3½	10	2½	—	3½
600	6	3½	5	11	8½	16	10½	2½	4½	¾	2½	5½	4½	1½	2½	5½	4½	4½	13½	7-7½	5½	7½	5½	3½	10½	3	—	3½
700	7	4½	5½	12½	10½	18	11½	2½	5	1½	2½	6	5½	1½	2½	5½	5½	5½	15½	8-7½	6½	8½	7½	4½	12	3½	—	3½
800	8	4½	5½	13½	10½	19	12½	2½	5½	1½	2½	6½	5½	1-7½	3	6½	5½	5½	16½	9-7½	6½	9½	7½	4½	12½	4	—	4
10	10	5	6½	16½	11½	23	14½	3-7½	6	1½	3½	8½	6½	1½	2	7½	6½	6½	19-7½	11½	7½	11-7½	8½	5½	14½	5	2½	7½
12	12	6	7½	19½	13½	26	16½	4	6½	1½	3½	10½	7½	1½	2½	8½	7½	7½	22	14	8½	13½	9½	6	17½	6	3	8½
14	14	7	8½	22½	15½	30	19	4½	7½	1½	4½	11½	8½	1½	2½	10	9	8½	25½	16½	10½	15½	11½	6½	20½	7	3½	10½

Shaft tolerances conform to B.S.1916:1953, h6. Keyways are to B.S.46:1958.
Refer to page 18 for Standard Shaft Tolerances and Keyway Details.
The facing V₁ is provided on Sizes 10, 12 and 14 only.

Principal dimensions (inches)

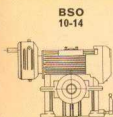

BSO
10-14



BSO
400-800

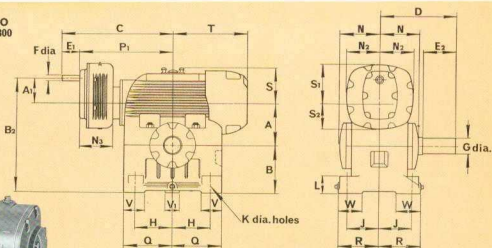
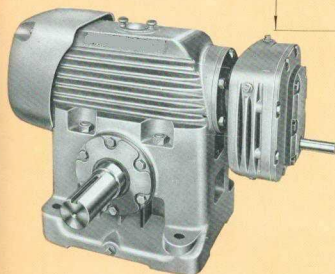

Shaft Handling

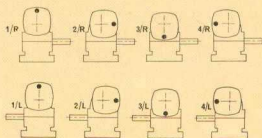

BSO

Size	A	A ₁	B	B ₁	C	D	E ₁	E ₂	F	G	H	J	K	L	N	N ₂	N ₃	P ₁	Q	R	S	S ₁	S ₂	T	V	V ₁	W
400	4	3	4½	11½	13½	8½	2-7/8	3½	¾	1½	4½	4	1-1/8	1-1/8	4½	4½	4½	11-7/8	5½	5	4½	5	3½	8½	2½	—	3
500	5	3	5½	13½	14½	9½	2-7/8	4	¾	2	4½	4½	1-1/8	2½	5½	4½	4½	12-7/8	6-7/8	5½	4½	5	3½	10	2½	—	3½
600	6	3½	6½	16½	16	10½	2½	4½	¾	2½	5½	4½	1-1/8	2½	5½	4½	4½	13½	7-7/8	5½	4½	5½	3½	10½	3	—	3½
700	7	4½	7½	19½	18	11½	2½	5	1½	2½	6	5½	1-1/8	2½	5½	5½	5½	15½	8-7/8	6½	6½	7½	4½	12	3½	—	3½
800	8	4½	8½	21½	19	12½	2½	5½	1½	2½	6½	5½	1-7/8	3	6½	5½	5½	16½	9-7/8	6½	6½	7½	4½	12½	4	—	4
10	10	5	10½	25½	23	14½	3-7/8	6	1½	3½	8½	6½	1½	2	7½	6½	6½	19-7/8	11½	7½	7½	8½	5½	14½	5	2½	7½
12	12	6	13	31	26	16½	4	6½	1½	3½	10½	7½	1½	2½	8½	7½	7½	22	14	8½	8½	9½	6	17½	6	3	8½
14	14	7	15	36	30	19	4½	7½	1½	4½	11½	8½	1½	2½	10	9	8½	25½	16½	10½	9½	11½	6½	20½	7	3½	10½

Shaft tolerances conform to B.S.1916:1953, h6. Keyways are to B.S.46:1958.
Refer to page 18 for Standard Shaft Tolerances and Keyway Details.
The facing V₁ is provided on Sizes 10, 12 and 14 only.

Type BS double reduction Principal dimensions (inches)

BSV
10-14

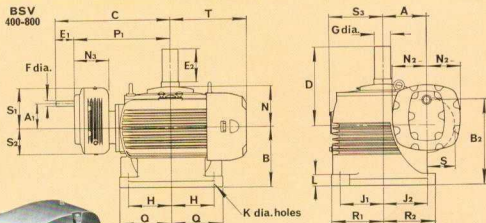
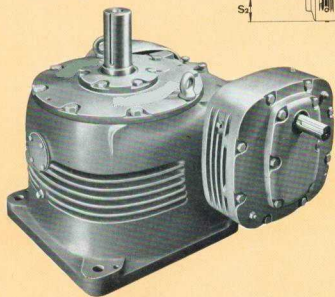
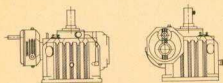

Shaft Handling

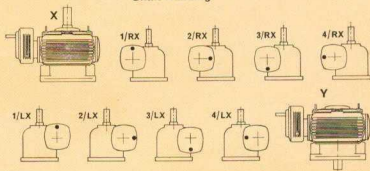

BSV

Designations with suffix "X", e.g. "1/RX", denote units with slow-speed shafts extended vertically upward. Suffix "Y", e.g. "1/RX", refers to units with slow-speed shafts extended vertically downward. Note: The slow speed shaft extension, when downward, is the same dimensionally as the upward projection from the high speed shaft centre-line. Dimensions D, E, and N apply to both arrangements

Size	A	A ₁	B	B ₂	C	D	E ₁	E ₂	F	G	H	J ₁	J ₂	K	L	N	N ₂	N ₂	P ₁	Q	R ₁	R ₂	S	S ₁	S ₂	S ₃	T
400	4	3	6 $\frac{1}{2}$	9 $\frac{1}{2}$	13 $\frac{1}{2}$	8 $\frac{1}{2}$	2 $\frac{7}{8}$	3 $\frac{1}{2}$	2	1 $\frac{1}{2}$	4 $\frac{1}{2}$	4 $\frac{1}{2}$	4 $\frac{1}{2}$	1 $\frac{1}{2}$	4 $\frac{1}{2}$	4 $\frac{1}{2}$	4 $\frac{1}{2}$	4 $\frac{1}{2}$	11 $\frac{1}{2}$	5 $\frac{1}{2}$	5 $\frac{1}{2}$	5 $\frac{1}{2}$	4 $\frac{1}{2}$	5	3 $\frac{1}{2}$	6	8 $\frac{1}{2}$
500	5	3	7 $\frac{1}{2}$	10 $\frac{1}{2}$	14 $\frac{1}{2}$	9 $\frac{1}{2}$	2 $\frac{7}{8}$	4	2	2	5 $\frac{1}{2}$	5 $\frac{1}{2}$	5 $\frac{1}{2}$	1 $\frac{1}{2}$	5 $\frac{1}{2}$	4 $\frac{1}{2}$	4 $\frac{1}{2}$	4 $\frac{1}{2}$	12 $\frac{1}{2}$	6 $\frac{1}{2}$	6 $\frac{1}{2}$	6 $\frac{1}{2}$	4 $\frac{1}{2}$	5	3 $\frac{1}{2}$	7	10
600	6	3 $\frac{1}{2}$	8 $\frac{1}{2}$	11 $\frac{1}{2}$	16	10 $\frac{1}{2}$	2 $\frac{1}{2}$	4 $\frac{1}{2}$	2 $\frac{1}{2}$	2 $\frac{1}{2}$	6	6	6	1 $\frac{1}{2}$	5 $\frac{1}{2}$	4 $\frac{1}{2}$	4 $\frac{1}{2}$	4 $\frac{1}{2}$	13 $\frac{1}{2}$	7 $\frac{1}{2}$	7 $\frac{1}{2}$	7 $\frac{1}{2}$	5 $\frac{1}{2}$	5 $\frac{1}{2}$	3 $\frac{1}{2}$	7 $\frac{1}{2}$	10 $\frac{1}{2}$
700	7	4 $\frac{1}{2}$	9	13 $\frac{1}{2}$	18	11 $\frac{1}{2}$	2 $\frac{1}{2}$	5	1 $\frac{1}{2}$	2 $\frac{1}{2}$	7	7	7	1 $\frac{1}{2}$	1 $\frac{1}{2}$	5 $\frac{1}{2}$	5 $\frac{1}{2}$	5 $\frac{1}{2}$	15 $\frac{1}{2}$	8 $\frac{1}{2}$	8 $\frac{1}{2}$	8 $\frac{1}{2}$	5 $\frac{1}{2}$	7 $\frac{1}{2}$	4 $\frac{1}{2}$	8 $\frac{1}{2}$	12
800	8	4 $\frac{1}{2}$	9 $\frac{1}{2}$	14	19	12 $\frac{1}{2}$	2 $\frac{1}{2}$	5 $\frac{1}{2}$	1 $\frac{1}{2}$	2 $\frac{1}{2}$	8	8	8	1 $\frac{1}{2}$	1 $\frac{1}{2}$	6 $\frac{1}{2}$	5 $\frac{1}{2}$	5 $\frac{1}{2}$	16 $\frac{1}{2}$	9 $\frac{1}{2}$	9 $\frac{1}{2}$	9 $\frac{1}{2}$	5 $\frac{1}{2}$	7 $\frac{1}{2}$	4 $\frac{1}{2}$	10	12 $\frac{1}{2}$
10	10	5	11	16	23	14 $\frac{1}{2}$	3 $\frac{7}{8}$	6	1 $\frac{1}{2}$	3 $\frac{1}{2}$	10 $\frac{1}{2}$	10 $\frac{1}{2}$	9 $\frac{1}{2}$	1 $\frac{1}{2}$	2	7 $\frac{1}{2}$	6 $\frac{1}{2}$	6 $\frac{1}{2}$	19 $\frac{1}{2}$	12 $\frac{1}{2}$	11 $\frac{1}{2}$	10 $\frac{1}{2}$	6 $\frac{1}{2}$	8 $\frac{1}{2}$	5 $\frac{1}{2}$	11 $\frac{1}{2}$	14 $\frac{1}{2}$
12	12	6	12	18	26	16 $\frac{1}{2}$	4	6 $\frac{1}{2}$	1 $\frac{1}{2}$	3 $\frac{1}{2}$	12 $\frac{1}{2}$	12 $\frac{1}{2}$	10 $\frac{1}{2}$	1 $\frac{1}{2}$	2 $\frac{1}{2}$	8 $\frac{1}{2}$	7 $\frac{1}{2}$	7 $\frac{1}{2}$	22	14 $\frac{1}{2}$	14	12	7 $\frac{1}{2}$	9 $\frac{1}{2}$	6	14	17 $\frac{1}{2}$
14	14	7	13	20	30	19	4 $\frac{1}{2}$	7 $\frac{1}{2}$	1 $\frac{1}{2}$	4 $\frac{1}{2}$	14	14	12	1 $\frac{1}{2}$	2 $\frac{1}{2}$	10	9	8 $\frac{1}{2}$	25 $\frac{1}{2}$	16 $\frac{1}{2}$	16 $\frac{1}{2}$	14 $\frac{1}{2}$	8 $\frac{1}{2}$	11 $\frac{1}{2}$	6 $\frac{1}{2}$	16 $\frac{1}{2}$	20 $\frac{1}{2}$

Shaft tolerances conform to B.S.1916:1953, h6. Keyways are to B.S.46:1958. Refer to page 18 for Standard Shaft Tolerances and Keyway Details.

STARTING EFFICIENCIES															
Gear box Size	Nominal Ratio	REVERSIBLE										NON REVERSIBLE (SELF LOCKING)			
		5/1	7.5/1	10/1	12.5/1	15/1	20/1	25/1	30/1	35/1	40/1	50/1	60/1	70/1	
112	Forward starting efficiency %	69	65	58	53	53	41	38	36	--	28	26	24	20	
	Reverse starting efficiency %	66	54	36	18	18	0	0	0	--	0	0	0	0	
133	Forward starting efficiency %	69	65	58	57	55	44	41	38	--	36	32	28	28	
	Reverse starting efficiency %	65	54	36	31	27	0	0	0	--	0	0	0	0	
162	Forward starting efficiency %	69	66	60	57	54	53	42	40	--	36	34	28	28	
	Reverse starting efficiency %	66	56	44	31	22	18	0	0	--	0	0	0	0	
200	Forward starting efficiency %	71	67	60	58	58	45	42	41	--	38	34	32	30	
	Reverse starting efficiency %	70	60	44	35	35	0	0	0	--	0	0	0	0	
237	Forward starting efficiency %	71	68	66	59	56	48	44	41	--	37	34	32	28	
	Reverse starting efficiency %	70	62	54	40	31	0	0	0	--	0	0	0	0	
287	Forward starting efficiency %	73	72	69	63	62	58	48	45	--	41	39	35	32	
	Reverse starting efficiency %	72	68	60	48	44	32	0	0	--	0	0	0	0	
337	Forward starting efficiency %	74	72	69	67	62	58	48	45	--	41	38	35	32	
	Reverse starting efficiency %	74	68	60	56	44	32	0	0	--	0	0	0	0	
400	Forward starting efficiency %	77	74	70	69	62	59	50	47	43	42	38	36	34	
	Reverse starting efficiency %	76	69	60	60	44	33	0	0	0	0	0	0	0	
500	Forward starting efficiency %	77	75	72	66	66	62	57	50	47	42	40	37	36	
	Reverse starting efficiency %	76	72	66	53	50	43	30	0	0	0	0	0	0	
600	Forward starting efficiency %	76	75	72	70	68	64	57	52	48	47	42	40	36	
	Reverse starting efficiency %	76	72	68	63	57	48	30	12	0	0	0	0	0	
700	Forward starting efficiency %	77	76	72	70	69	62	59	52	48	48	46	42	37	
	Reverse starting efficiency %	76	73	68	63	58	43	36	12	0	0	0	0	0	
800	Forward starting efficiency %	76	76	73	72	70	66	62	57	53	48	44	42	37	
	Reverse starting efficiency %	76	75	69	65	60	50	44	30	18	0	0	0	0	
1000	Forward starting efficiency %	76	76	75	--	71	67	62	59	--	52	47	42	--	
	Reverse starting efficiency %	76	75	72	--	64	57	44	33	--	12	0	0	--	
1200	Forward starting efficiency %	--	76	75	--	72	68	64	61	--	53	48	44	--	
	Reverse starting efficiency %	--	76	72	--	67	58	47	40	--	18	0	0	--	
1400	Forward starting efficiency %	--	76	76	--	72	69	66	61	--	53	48	47	--	
	Reverse starting efficiency %	--	75	74	--	66	50	50	42	--	18	0	0	--	
1700	Forward starting efficiency %	76	76	76	75	73	70	67	62	62	58	51	47	44	
	Reverse starting efficiency %	76	76	73	71	69	59	56	40	40	32	6	0	0	

Note :

1. Because of variations in the coefficient of friction which are due to differing conditions of materials, surface finish, lubricants etc., these efficiencies should be regarded as approximate and could vary a few percent either way. The above efficiencies are based on current stock ratios.
2. The gears indicated as being "reversible" are capable of being driven from the wormwheel at all speeds including from rest. If the application requires the wormwheel to be the driving member for any length of time it is preferable to choose a ratio well to the left of the line to obtain a high reverse efficiency.
3. Gears indicated as being " not reversible" are self locking only when at rest and provided that no vibrations are present i.e. as from adjacent working machinery.
4. Gears between the two lines can not safely be considered as being either reversible or non reversible. If reversibility or non reversibility is specifically required gears to the left or right of the respective lines should be selected.
5. Due to gears of sizes higher than 17 being made, wherever possible, to suit application, it is not possible to provide any specific starting efficiencies. If approximate ones are required full details of the application should be supplied.
6. The term "reversible" is used here to mean that the wormwheel is driving the wormshaft.



PREMIUM

GREAVES

Speed Reducers

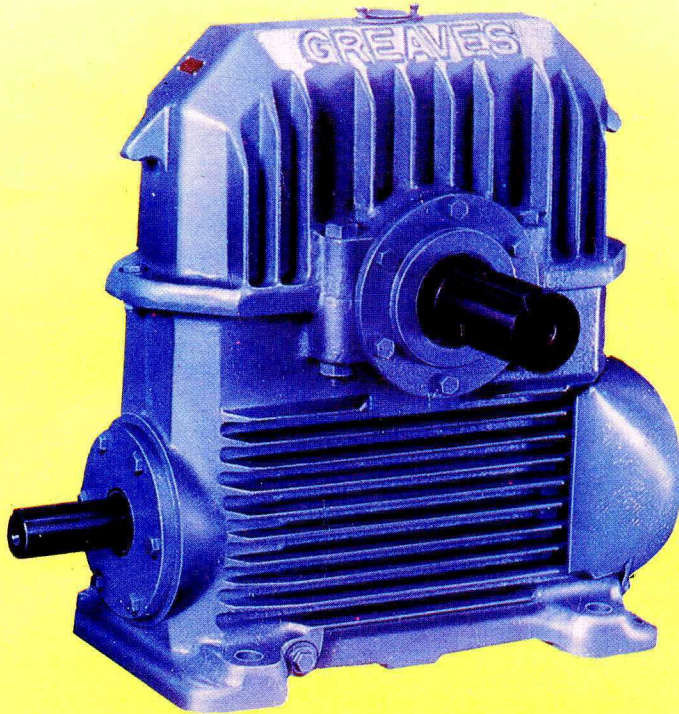

Installation and Maintenance



PREMIUM

GREAVES

SOLID FOOT & ADAPTABLE WORM REDUCERS

Installation and Maintenance

GENERAL

The Greaves Speed Reducer is a precision product incorporating the very best in worm gear design. It is a self-contained unit of simple rigid construction involving the minimum number of moving parts and embodying a lubrication system which ensures a positive supply of oil to gears and bearings at all running speeds. With careful installation Greaves

Speed Reducers will give complete reliability in service and the only attention necessary is an occasional oil level check.

This publication gives information on correct installation, thus ensuring that the high initial efficiency is unimpaired in operation.

INSTALLATION

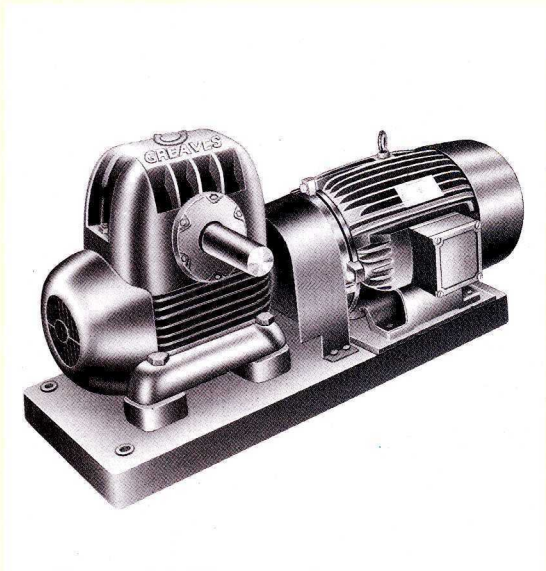

It is preferable, although not essential, to mount the gear unit and prime mover on a common bedplate. Any foundation used should be rigid so as to minimise the effect of fluctuating or heavy loads. When lowering a bedplate on to its foundation flat steel packings should be used, placed on either side and as close as possible to each foundation bolt. Packings should also be placed in such a position that support is given in the plane of the coupling faces. Care must be taken so as not to spring the bedplate when the final bolting down is carried out after the unit and prime mover have been lined up, as strains may be set up in the gear casing and errors of alignment in shafts and gears may be introduced. It is advisable to check the alignment after bolting down, even when a gear unit and motor have been assembled and lined up on a bedplate.

After installation and lining up has taken place, the two opposite feet should be drilled, reamed and dowels fitted.

ALLOWANCE FOR BEARING CLEARANCE

Where a Greaves Speed Reducer with shafts mounted on ball or roller bearings, is coupled to a prime mover or a driven machine with plain bearings, an allowance for "lift" should be made to accommodate the probable change in centre height when running, due to thickness of the oil film and

upward reaction (if any) under load.

No hard and fast rule can be given as to the exact amount of correction to allow and this, dependent upon so many factors peculiar to individual cases, is largely a matter of experience.

EFFECT OF TEMPERATURE

Any change in temperature will alter the height of a shaft above its foundations. If there is much difference between the temperature of a gear casing and that of the driven machine, or prime mover, the resulting difference in level may be appreciable. The coefficient of linear expansion of cast iron is 0.000011mm per mm per °C; hence with a centre height of 500mm. above the bedplate and difference in temperature of 30°C between the gear casing and

the machine, the error of alignment, if correct when cold, will be 0.165mm.

Such conditions may, particularly in the case of large units and those which are close-coupled, impose very severe loads on the bearings. If this is so, it is recommended that an allowance be made so that the alignment will be more nearly correct under normal working conditions.

LINING UP

Errors of alignment fall into the categories of angularity (Fig. 1) and eccentricity (Fig. 2), or combinations of both. Angularity error should be corrected first by using feeler gauges (Fig. 3) and arriving at a constant gap measured every 90° of rotation, rotating both halves simultaneously.

Eccentricity error can be corrected by using a straight

edge (Fig. 4) if both couplings have the same outside diameter. If not a straight edge should be used in conjunction with a feeler gauge equal to half the difference in diameters. Here also checking should be done every 90° while rotating both halves simultaneously.

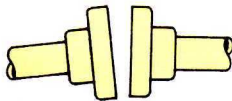

Fig. 1

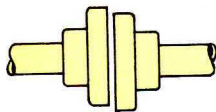
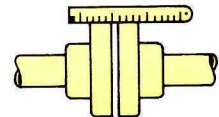
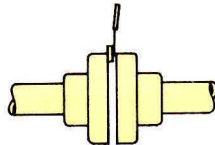

Fig. 2



Fig. 3



Fig. 4

CHANGING HANDING

When changing the handing of the slow speed shaft extension, the shaft complete with wormwheel, bearings etc. should be reversed as a unit. It should be appreciated that this has the effect of reversing the offset of the wheel relative to the worm. When changing the slow speed shaft handing of V type units it should be noted that the position of the wheel relative to the case must not be changed; it is necessary therefore to press the wheel from the shaft. The position of the shaft in relation to the wormwheel must be reversed. The end covers should be located in their respective positions. It is necessary to check contact markings on the wormwheel teeth and if any axial adjustment of the wormwheel is necessary, it can be effected by means of the shims between end covers and bearing housing which should be moved from one side to the other. It is essential that the top half of the gear case be replaced in its original position.

The contact marking is checked by painting the worm with red lead or Prussian Blue and rotating the worm

by hand while applying a small braking pressure to the wheel, also by hand.

The correct marking should be slightly heavier on the "leaving side" of the teeth, relative to the direction of rotation of the worm, so as to provide "lead in" for the lubricant and to avoid concentration of pressure on the entering side as this would affect the smoothness of operation. This arrangement is shown in the diagrams. When the correct wheel setting has been reached on the U type speed reducers, the oil scraper clearance relative to the wormwheel should be set at 0.25 mm to 0.38 mm.

If Gearbox is dismantled for maintenance, while re-assembling care should be taken to gently scrape the joint faces and apply 'LOCTITE FLANGE SEALANT SUPERFAST 574' joint compound on faces of cases and covers and catchers of all type units. But for sizes U/O 1000 and above paper packings of size supplied by Greaves to be used between two halves of the case joints.

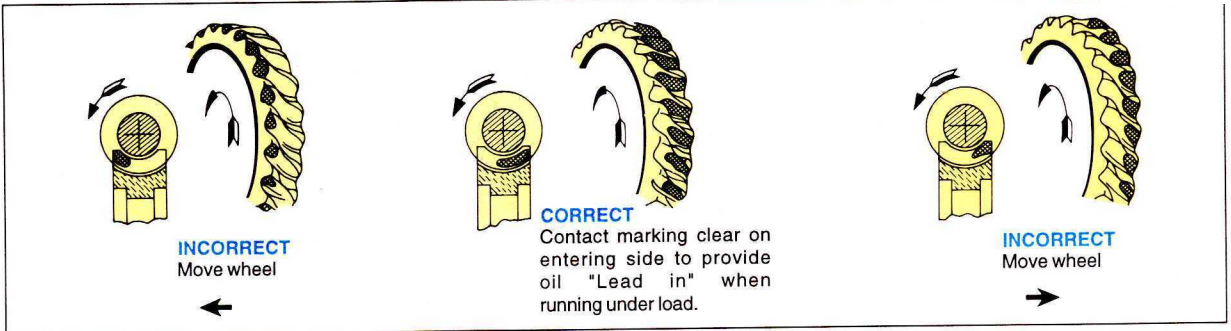

AXIAL FLOATS

After assembling it is essential that shaft end floats be correctly set. The following axial floats for wormshaft and wheelshaft are recommended. However it is better to maintain axial float at lower

recommended value. They should be checked preferably using a dial indicator gauge mounted on a magnetic base.

SIZE	WORMSHAFT (mm)	WHEELSHAFT (mm)
112	0.025/0.075	0.025/0.050
162	0.025/0.075	0.025/0.050
200	0.025/0.075	0.025/0.050
237	0.025/0.075	0.025/0.050
287	0.025/0.075	0.025/0.050
337	0.025/0.075	0.025/0.050
400	0.050/0.100	0.025/0.050

SIZE	WORMSHAFT (mm)	WHEELSHAFT (mm)
500	0.050/0.100	0.025/0.050
600	0.050/0.100	0.025/0.050
700	0.050/0.100	0.025/0.075
800	0.050/0.100	0.025/0.075
1000	0.050/0.100	0.025/0.075
1200	0.075/0.125	0.050/0.100
1400	0.075/0.125	0.050/0.100
1700	0.075/0.125	0.050/0.100

LUBRICATION

The Greaves Speed Reducer lubrication system is self contained positive and automatic at all speeds of operation and in either direction of rotation. Adaptable units are provided with breather, oil level and drain plugs and it must be ensured that these are correctly positioned as shown on the accompanying diagram. Other units incorporate a dipstick for oil level checking, an oil filler-cum-ventilator and drain plugs. Their locations are shown on the following page.

Greaves Speed Reducer units are supplied without oil and must be filled with the correct grade of lubricant to the correct level. It is important to ensure that the correct oil level is not exceeded as over filling causes oil churning, resulting in overheating and leakage.

RECOMMENDED LUBRICANT ISO VG320

Brand	Grade
Bharat Petroleum	Cabol 320 or Amocam 320
Castrol	Alpha ZN320
Gulf	Harmony 320
Hindustan Petroleum	Enklo 320
Indian Oil	Servomesh SP320 or Servosystem 320
Veedol	Avalon 320

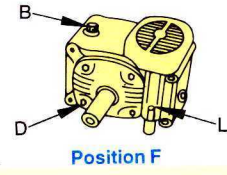
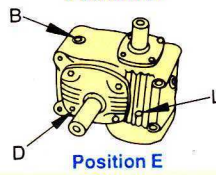
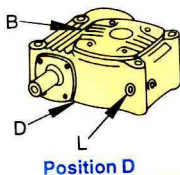
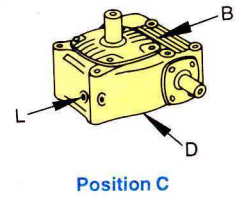
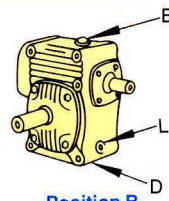
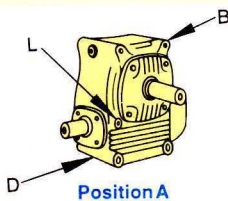

MAINTENANCE

(1) WEEKLY INSPECTION

(a) Check the oil level by means of the dipstick or oil level plug and if necessary, top up with the recommended grade of lubricant.

(b) Ensure that breathers are cleaned regularly. Care must be taken not to paint over the breathers, otherwise pressure will build up, resulting in oil leakage.

(c) On units having grease lubricated bearings, add two shots of grease from a grease gun, or where screw-in type lubricators are fitted, screw in the lubricator two turns and refill when necessary with the recommended grease.

(2) OIL CHANGES

Regular oil changes are essential to ensure that the unit gives long and trouble-free service. The frequency at which the oil should be changed is determined by the following factors :

- (a) Oil temperature----unit operating under load
- (b) Type of oil---plain or containing additives
- (c) Environment----humidity, dust etc.
- (d) Operating conditions----shock loading etc.

At elevated temperatures the effective life of the oil is very much reduced. This is most pronounced when the oil contains fatty and E.P. additives. To prevent unit damage through lubricant breakdown, the oil should be renewed as shown in the following tables :

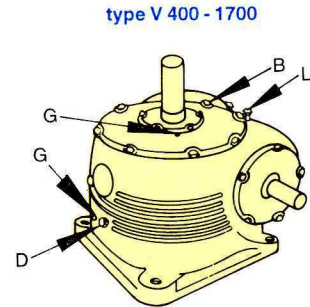
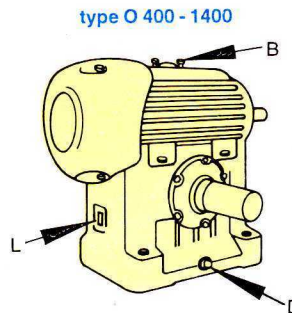
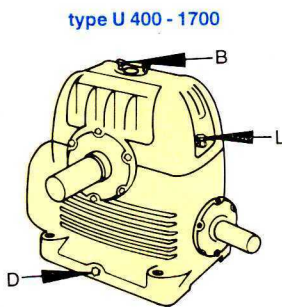

Using Plain Mineral Oil

Temp. °C	Adaptables	Other Units
75 or less	2500 hr. or 6 months	5000 hr. or 12 months
80	2000 hr. or 6 months	3500 hr. or 6 months
85	1500 hr. or 3 months	2500 hr. or 6 months
90	1000 hr. or 3 months	1000 hr. or 3 months

---whichever is the shorter period

Using Oils Containing Additives

Temp. °C	Adaptables	Other Units
75 or less	2500 hr. or 6 months	5000 hr. or 12 months
80	1500 hr. or 6 months	3000 hr. or 6 months
85	1000 hr. or 3 months	2000 hr. or 6 months
90	750 hr. or 3 months	750 hr. or 3 months

---whichever is the shorter period

Note : Figures quoted in the table are for oil temperatures when the unit has attained **normal running temperature when operating under load.** These figures are based on normal running but where

conditions are particularly severe it may be necessary to change the oil more frequently. Consult the lubricant supplier regarding presence of E.P. additives in the grades supplied by them.

Primary Units on type AUD, AOD, AVD Units Sizes 162 - 337

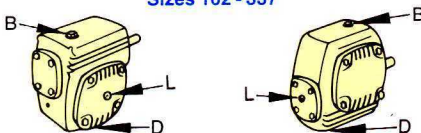

Primary Units on type UD and VD Units Sizes 400 - 1700 and on types OD Sizes 400 - 1400

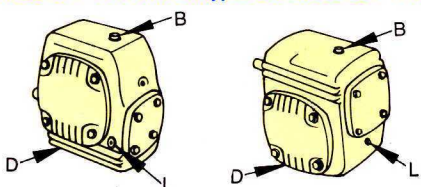

Dipstick as fitted on units size 1000 and above

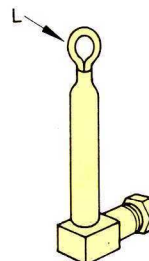

- B - Breather/Filler plug
- L - Oil level Plug/dipstick
- D - Drain plug
- G - Grease lubricator

OIL CAPACITIES FOR FIRST FILLING (in litres)

SINGLE REDUCTION UNITS

ADAPTABLE UNITS

SIZE	112	162	200	237	287	337
A	0.1	0.3	0.3	0.6	0.9	1.4

TYPES U,O,V

SIZE	400	500	600	700	800	1000	1200	1400	1700
U	3.0	4.3	6.3	9.1	11.4	17.5	23.0	37.0	45.0
O	2.3	2.8	4.0	5.7	9.1	11.0	15.0	24.0	--
V	4.0	5.7	6.3	10.2	12.5	22.7	37.4	68.5	105

DOUBLE REDUCTION UNITS

TYPES AD

	SIZE	162	200	237	287	337
AUD AOD AVD	Primary Unit	0.1	0.1	0.3	0.3	0.3
	Secondary Unit	0.3	0.3	0.6	0.9	1.4

TYPES UD, OD, VD

	SIZE	400	500	600	700	800	1000	1200	1400	1700
UD	Primary Unit	0.6	0.6	1.1	1.7	2.8	4.0	5.7	9.1	11.4
	Secondary Unit	3.0	4.3	6.3	9.1	11.4	17.5	23.0	37.0	45.0
OD	Primary Unit	0.6	0.6	1.1	1.7	2.8	4.0	5.7	9.1	--
	Secondary Unit	2.3	2.8	4.0	5.7	9.1	11.0	15.0	24.0	--
VD	Primary Unit	0.6	0.6	1.1	1.7	2.8	4.0	5.7	9.1	11.4
	Secondary Unit	4.0	5.7	6.3	10.2	12.5	22.7	37.4	68.5	105

The above oil quantities are approximate as improvements in design are continually being made. This specification is not to be regarded as binding in detail and dimensions are subject to alteration without notice.

Oil level has to be maintained as per dipstick level marking.

TROUBLE SHOOTING CHART

SYMPTOM	TYPICAL CAUSES																		
	Lubricant			Oilseal Lip		Clogging of Breather	Play		Improper Contact	Backlash		Environmental			Alignment	Operational			
	Unsuitable	Insufficient	Overfilling	Hardened	Damaged		Excess	Less		More	Less	Dust	Heat	Chemical		Overload	Vibration	High Speed	Low Speed
Oilseal Leakage	*		*	*	*	*						*	*	*	*			*	
Noise	*	*					*		*	*				*				*	
Over Heating	*	*	*			*	*	*	*	*	*				*			*	*
Bearing Failure	*	*					*	*						*	*			*	*
Wormwheel Worn Out	*	*					*	*	*	*					*				
Joint Leakage	*		*			*						*					*		
Oil Oozing out through Ventilator	*		*			*												*	
Oil Leakage through Output Oilseal (V Type)			*																

SPECIAL POINTS TO BE OBSERVED :

• Use of correct grade of oil. • Fill oil to the correct level. • Change oil periodically. • Check alignment of Input and Output Shaft. • Ventilator to be kept clean.



GREAVES LIMITED

• **WESTREN REGION:** Industry Manor, Appasaheb Marathe Marg, Prabhadevi, Mumbai-400 025. Ph: 022-4223747, 4365510, Fax: 022-437 9555, e-mail: mumbg2@greavesmail.com • **NORTHERN REGION :** Express Building Annexe, Bahadur Shah Zafar Marg, P. B. No.7024, New Delhi-110 002, Ph: 011-3730554, Fax: 011-3359782, e-mail: delbg2@greavesmail.com • **EASTERN REGION:** Thapar House, 25, Brabourne Road, P. B. No.702, Kolkata-700 001. Ph: 033-2423805, 2424316, Fax: 033-2424325, e-mail: calbg2@greavesmail.com • **SOUTHERN REGION:** 26, Second Line Beach, P. B. No. 207, Chennai-600 001, Ph: 044-5231120, Fax: 044-5224557, e-mail: chebg2@greavesmail.com • **FOREIGN OFFICE :** James Greaves & Company, G. P. O. Box 406, Brazennose House, Brazennose Street, Manchester M60 2JA, United Kingdom, Ph: 0044-161-834-0991, Fax: 0044-161-832-0753 e-mail: jamesgreavesco@btinternet.com
Website : www.greaveslimited.com

GREAVES MOTORISED LIFT DRIVE UNITS

SALIENT FEATURES:

GREAVES MOTORISED WORM REDUCERS OF LIFT DRIVE UNIT ARE OF SUBSTANTIAL CONSTRUCTION COMBINING RIGIDITY WITH COMPACTNESS IN UNI-CAST CASING, THEREBY ELIMINATING COUPLING AND RELATED HAZARDS OF ACHIEVING ALIGNMENT. THE DESIGN OF SINGLE PIECE HIGH QUALITY CLOSE-GRAINED CAST IRON CASE IS COMPUTER OPTIMISED ON CAD WORKSTATION WHICH PROVIDES PRECISELY CALCULATED STRENGTHENING RIBS AND OPTIMAL WALL THICKNESS IN CRITICAL LOAD CARRYING AREAS.

THE CENTRIFUGALLY CAST PHOSPHOR-BRONZE WORM WHEEL AND CASE-HARDENED, THREAD-GROUND ALLOY STEEL WORM ARE COMBINED WITH THE MINIMUM BACKLASH TO CATER FOR PASSENGER LIFT. THE OUTPUT SHAFT MANUFACTURED FROM DIRECT HARDENING HIGH TENSILE ALLOY STEEL IS SUFFICIENTLY CAPABLE TO TRANSMIT HIGH TORQUE. THE SELF LOCKING PHENOMENON OF WORM DRIVE AT DESIRED RATIO ENSURE ABSOLUTE SAFETY OF THE LIFT UNIT.

S4 DUTY AC INDUCTION MOTORS WITH DIE CAST ALUMINIUM ROTOR ENSURES HIGH STARTING TORQUE, LOW STARTING CURRENT AND SMOOTH ACCELERATION CHARACTERISTICS ESSENTIALLY REQUIRED IN LIFT DUTY APPLICATION. THESE FLANGE MOUNTED 6/4 POLE 3 PHASE INDUCTION MOTORS ARE MEANT FOR INTERMITTENT PERIODIC DUTY WITH STARTING AND ENSURE SILENT RUNNING AND LONG OPERATING LIFE AGAINST PARTICULAR REQUIREMENTS OF HIGH DEGREE OF QUIETNESS. TEFC TYPE OF ENCLOSURE ENHANCES VENTILATION AND CONSIDERABLY REDUCES THE HEAT GENERATION.

FAIL-SAFE ELECTROMAGNETIC SHOE BRAKES ARE DESIGNED TO OPERATE ON 120 VOLTS D.C. THE BRAKE DRUM-CUM-FLY WHEEL IS MOUNTED ON WORM SHAFT EXTENSION OPPOSITE TO THE MOTOR END, RESULTING THE BRAKING TORQUE APPLIED AWAY FROM THE PRIME MOVER. THE BRAKING EFFECT THROUGH TWO COIL SPRINGS MAY BE MANUALLY RELEASED FOR EMERGENCY HOISTING UNDER POWER FAILURE. THE 3-GROOVE DRIVE PULLEY IS IN 2-PIECE CONSTRUCTION HAVING REMOVABLE SHEAVE BOLTED WITH FIXED HUB.

TECHNICAL SPECIFICATION:

SL NO	PARAMETERS	LIFT DRIVE GEARBOX SIZES				
		100	125	150	175	200
01	Rated Power (kW)	2.78	4.53	7.35	7.75	10.90
02	Output Torque (Nm)	777	1280	2196	2490	3540
03	Input RPM	1000	1000	1000	1500	1500
04	Motor Power (kW)	2.2	3.7	5.5	5.5	7.5
05	Motor Frame	100L	132S	132M	132S	132M
06	Reduction Ratio	40/1	40/1	40/1	70/1	70/1
07	Carrying Capacity (No. of passengers @ 68 kg per person)	4	6	8	10	12
08	Sheave Dia. (mm)	510	510	510	610	610
09	No. of grooves	3/4	3/4	3/4	3/4	3/4
10	Pulley RPM	25	25	25	21.4	21.4
11	Lift Speed (m/s)	0.67	0.67	0.67	0.68	0.68
12	Brake Drum Dia. (mm)	150	200	200	254	254
13	App. Weight (kg)	275	325	375	575	650

The above said specifications are meant for selection of standard drives against usual applications. Our engineers will be pleased to assist in case of special requirements towards specific applications.

TECHNICAL SPECIFICATIONS

MOTORISED LIFT DRIVE UNITS WITH LIFT SPEED 1 MTR/SEC

SL.NO.	PARAMETERS	LIFT DRIVE GEARBOX SIZES				
		100	125	150	175	200
1	RATED POWER (KW)	3.5	5.72	9.64	13.7	17.9
2	OUTPUT TORQUE (Nm)	673	1110	1960	2830	3740
3	INPUT RPM	1500	1500	1500	1500	1500
4	MOTOR POWER (KW)	3.7	5.5	7.5	9.3	11
5	MOTOR FRAME	112M	132S	132M	160M	160M
6	REDUCTION RATIO	40/1	40/1	40/1	40/1	40/1
7	CARRYING CAPACITY (NO. OF PASSENGERS @ 68 KG/PERSON)	4	6	8	10	12
8	SHEAVE DIA (MM)	510	510	510	510	510
9	NO. OF GROOVES	3	3	3	4	4
10	PULLEY RPM	37.5	37.5	37.5	37.5	37.5
11	LIFT SPEED (MTR/SECOND)	1	1	1	1	1
12	BRAKE DRUM DIA (MM)	150	200	200	254	254
13	APPROX WEIGHT (KG)	310	385	430	630	710
14	DELIVERY (IN NO. OF WEEKS)	8	6	6	8	8

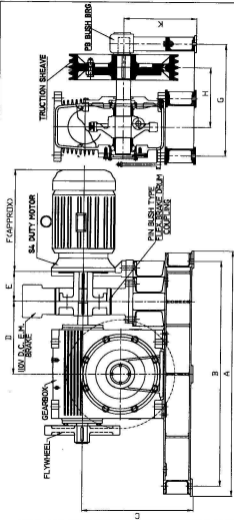

UNIT SIZE	A	B	C	D	E	F	G	H	K
AM 100	880	880	367.3	260	65	308	471	214	268.70
AM 125	980	970	414.1	277	80	308	501	232	287.10
AM 150	1017	987	473.5	304	95	408	481	248	303.80
AM 175	1180	1085	517.7	340	140	408	578.40	280	338.80

G.A. DESG. FOR NEW DESIGN
FOR AM 100, 125, 150 LIFT UNIT

SCALE 1/8" = 1"



SCALE 1/8" = 1"

SCALE 1/8" = 1"

SCALE 1/8" = 1"

SCALE 1/8" = 1"

LIFT NEW 001

**BACKLASH BETWEEN WORM & WORM WHEEL
AT SPECIFIED CENTRE**

SL.NO	CENTRE DISTANCE	BACKLASH	
		MINIMUM	MAXIMUM
1	1 1/8 "	0.002 "	0.008 "
2	1 5/8 "	0.002 "	0.010 "
3	2 "	0.002 "	0.011 "
4	2 3/8 "	0.003 "	0.012 "
5	2 7/8 "	0.003 "	0.013 "
6	3 3/8 "	0.003 "	0.013 "
7	4 "	0.004 "	0.011 "
8	5 "	0.005 "	0.012 "
9	6 "	0.006 "	0.013 "
10	7 "	0.007 "	0.014 "
11	8 "	0.008 "	0.015 "
12	10 "	0.010 "	0.017 "
13	12 "	0.012 "	0.019 "
14	14 "	0.014 "	0.021 "
15	17 "	0.017 "	0.024 "

GREAVES GEARS

PARTS LISTS

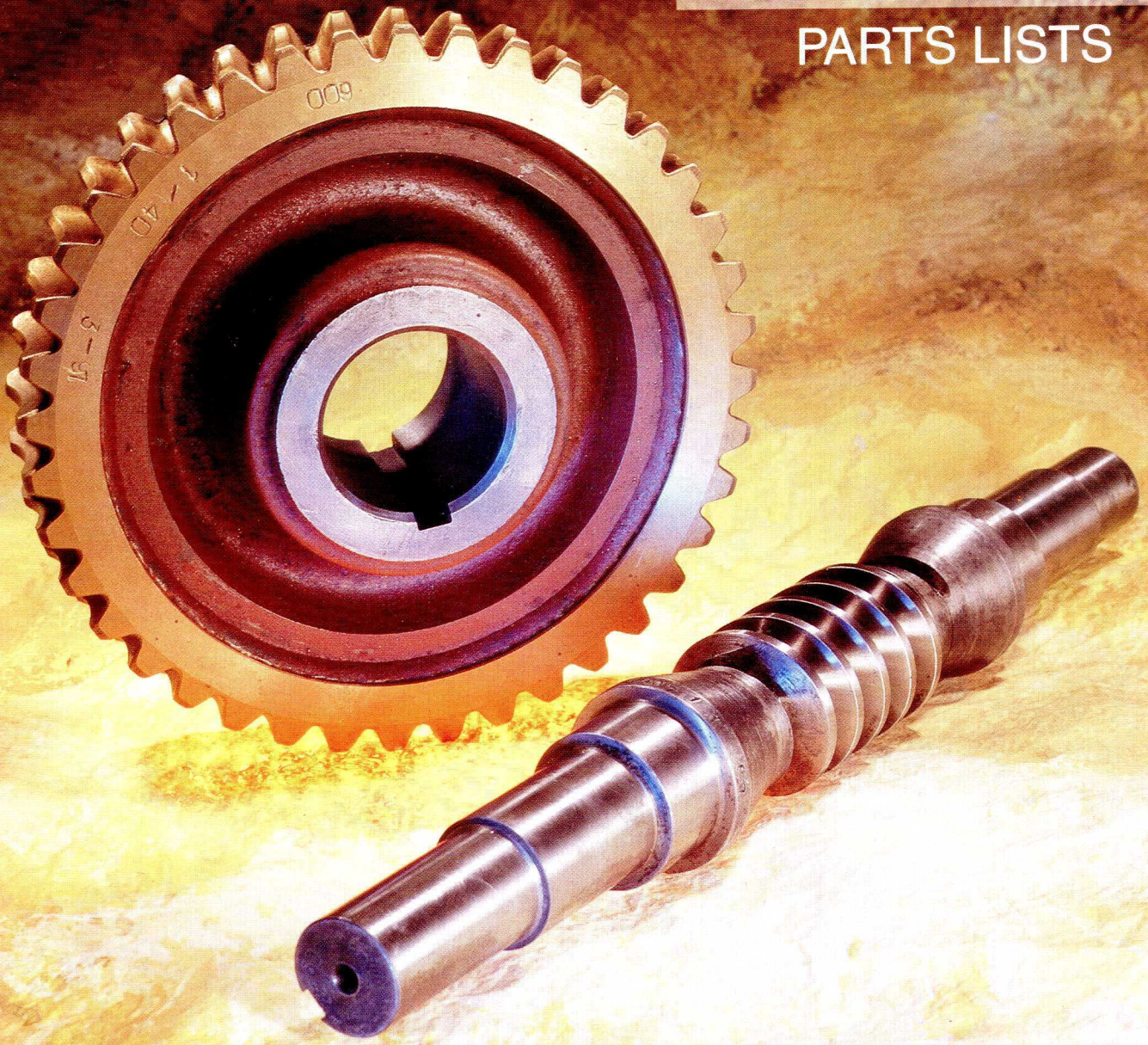

Identification

When ordering replacement parts quote from the name-plate, the order number, type, ratio and serial number. Identify the required part from the illustrations and parts lists shown on the subsequent pages and quote the item number together with its full description. For example :

GREAVES WORM REDUCER	
O.NO.	
TYPE	
RATIO	
SR.NO.	
MANUFACTURED BY GREAVES LIMITED POWER TRANSMISSION UNIT	

INDEX TO ILLUSTRATIONS

Type	Description	Page No.
A,AM	Adaptable units Sizes 112-337	3
AS,ASM	Adaptable shaft mounted units Sizes 162-337	4
U	Solid foot units-under driven type Sizes 400-800	5
U	Solid foot units-under driven type Sizes 1000-1700	6
O	Solid foot units-over driven type Sizes 400-800	7
O	Solid foot units-over driven type Sizes 1000-1400	8
V	Solid foot units-vertical output shaft Sizes 400-800	9
V	Solid foot units-vertical output shaft Sizes 1000-1700	10
AD	Adaptable double reduction units Sizes 162-337	11
UD	U type double reduction units Sizes 400-1700	12
OD	O type double reduction units Sizes 400-1400	13
VD	V type double reduction units Sizes 400-1700	14
	Greaves units with special features	15 to 21

Greaves units with special feature and/or with modifications are provided with a name-plates having an identification mark using one of the following codes:

DOS	—	Double extended output shaft
DIS	—	Double extended input shaft
DOIS	—	Double extended output and input shafts
W	—	One wider bearing on output shaft
2W	—	Two wider bearings on output shaft
HBC/HBA	—	Unit fitted with holdback device
MBL	—	Unit with minimum backlash gearing
SLA	—	Lift unit, with sleeve bearings on wormshaft
STR	—	Standard duty stirrer unit
HDS	—	Heavy duty stirrer unit
CT	—	Cooling tower unit
SP	—	Unit with modifications on shaft extensions etc.

Pages 15 to 21 give details of such units.

Adaptable Single reduction units

Sizes 112 to 337 (including motorised units)

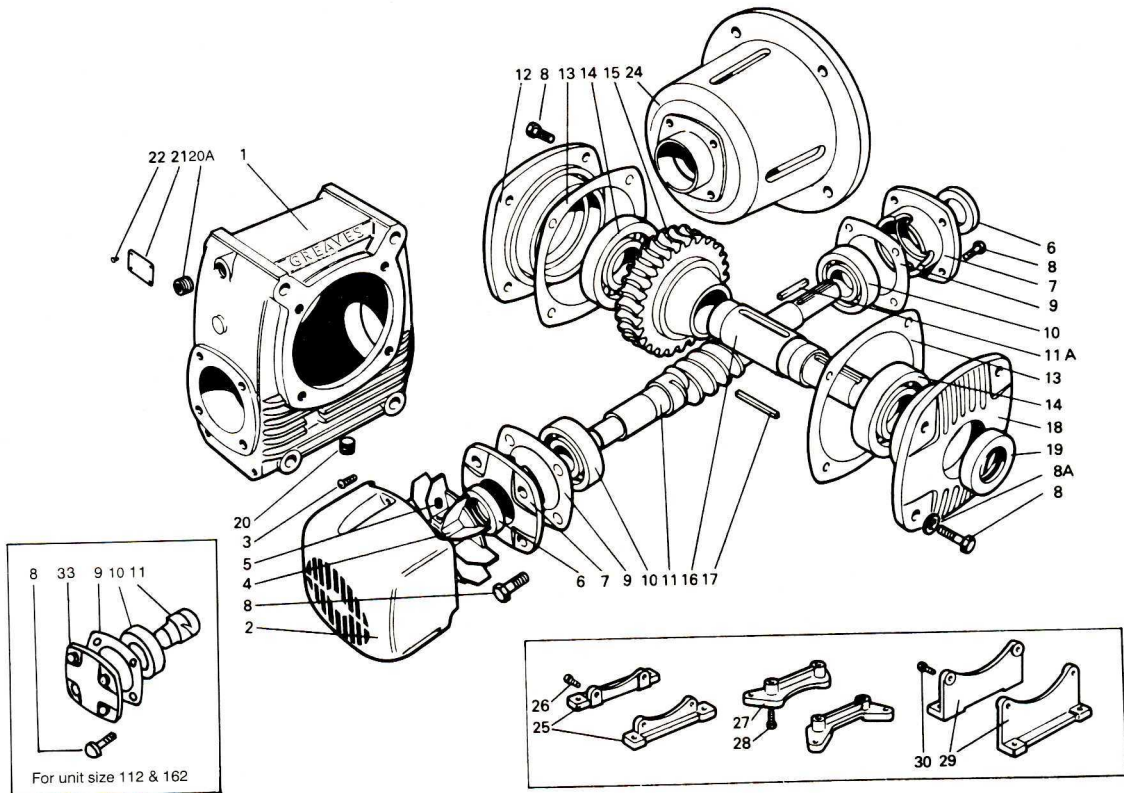

NAMEPLATE DETAILS ESSENTIAL FOR CORRECT PARTS IDENTIFICATION

- | | | | |
|-----|---|-----|---|
| 1 | Case | 16 | Wheelshaft |
| 2 | Cowl for sizes 200 to 337 | 17 | Key for wheelshaft |
| 3 | Screw for cowl for sizes 200 to 337 | 18 | Oil catcher for wheelshaft |
| 4 | Fan for sizes 200 to 337 | 19 | Oil seal for wheelshaft |
| 5 | Locking screw for fan for sizes 200 to 337 | 20 | Plug |
| 6 | Oil seal for wormshaft | 20A | Breather |
| 7 | Oil catcher for wormshaft | 21 | Nameplate |
| 8 | Bolt for wormshaft covers | 22 | Rivet for nameplate |
| *8A | Copper washer for end cover bolt | 24 | Adaptor flange for motorised unit only. Item 7, shaft extension end, not fitted |
| 9 | Shim for wormshaft oilcatcher | 25 | No.1 foot |
| 10 | Bearing for wormshaft | 26 | Bolt for No.1 foot |
| 11 | Wormshaft | 27 | No.2 foot |
| 11A | Key for wormshaft-supplied only when motor adaptor flange is fitted | 28 | Bolt for No.2 foot |
| 12 | End cover for wheelshaft | 29 | No.3 foot |
| 13 | Shim for wheelshaft covers | 30 | Bolt for No.3 foot |
| 14 | Bearing for wheelshaft | 31 | End cover for wormshaft for size 112 and 162 |
| 15 | Wormwheel | 32 | Input key |
| | | 33 | Output key |

Note: Item 2 to 5 are not required for unit sizes 112 and 162. Item 31 is only for unit sizes 112 and 162. Item 32 & 33 not shown.
*Copper washer, Item 8A: is fitted to each lower wheelshaft end cover bolt for unit sizes 112 and 162

Adaptable Shaft Mounted Units

Sizes 162 to 337 (including motorised units)

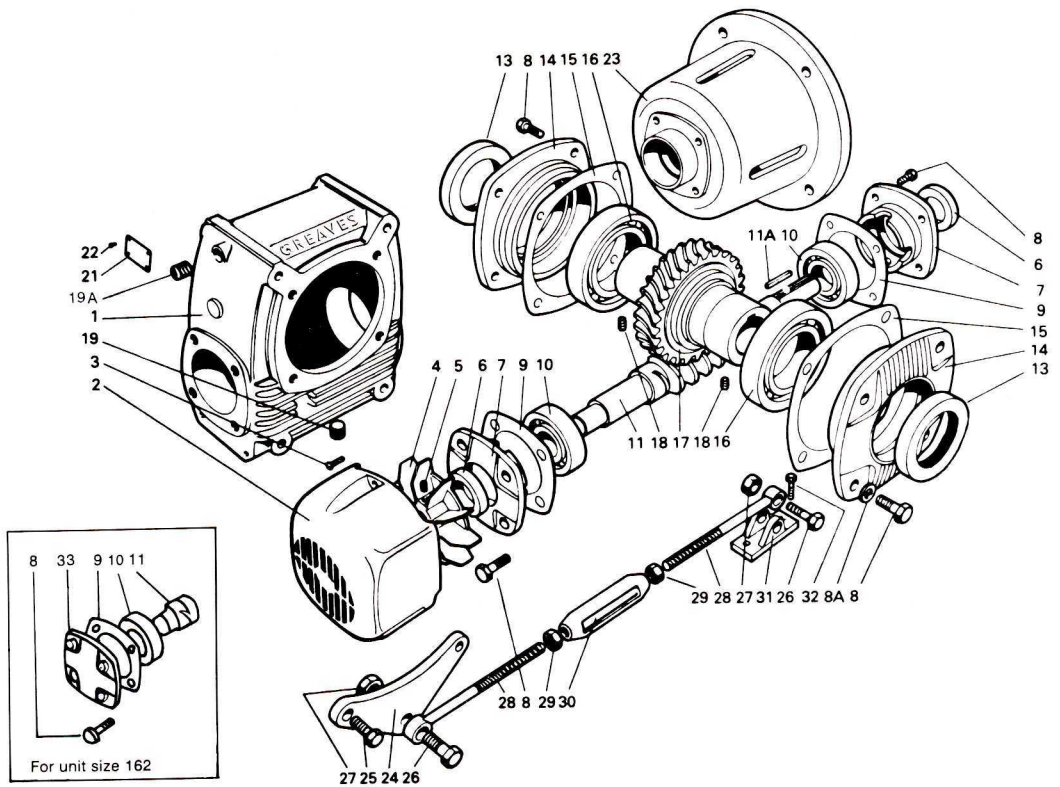

NAMEPLATE DETAILS ESSENTIAL FOR CORRECT PARTS IDENTIFICATION

1	Case	18	Locking screw for wheelshaft
2	Cowl for sizes 200 to 337	19	Plug
3	Screw for cowl for sizes 200 to 337	19A	Breather
4	Fan for sizes 200 to 337	21	Nameplate
5	Locking screw for fan for sizes 200 to 337	22	Rivet for nameplate
6	Oil seal for wormshaft	23	Adaptor flange for motorised unit only, item 7, at shaft extension end not fitted
7	Oilcatcher for wormshaft	24	Torque arm fixing bracket
8	Bolt for wormshaft covers	25	Bolt for bracket
*8A	Copper washer for end cover bolt	26	Shoulder bolt
9	Shim for wormshaft oil catcher	27	Nut for shoulder bolt
10	Bearing for wormshaft	28	Tie-rod for torque arm
11	Wormshaft	29	Locknut for tie-rod
11A	Key for wormshaft-supplied only when motor adaptor flange is fitted	30	Adjusting sleeve for torque arm
13	Oil seal for wheelshaft	31	Fixing bracket for torque arm
14	Oil catcher for wheelshaft	32	Bolt for bracket
15	Shim for wheelshaft cover	33	End cover for wormshaft for size 162
16	Bearing for wheelshaft	34	Input key
17	Wormwheel	35	Output key

Note : Item 2 to 7 are not required for unit size 162. Item 33 is only for unit size 162. Item 34 & 35 not shown
 *Copper washer, Item 8A: is fitted to each lower wheelshaft end cover bolt for unit sizes 112 and 162

Type 'U' Single Reduction Units

Sizes 400 to 800

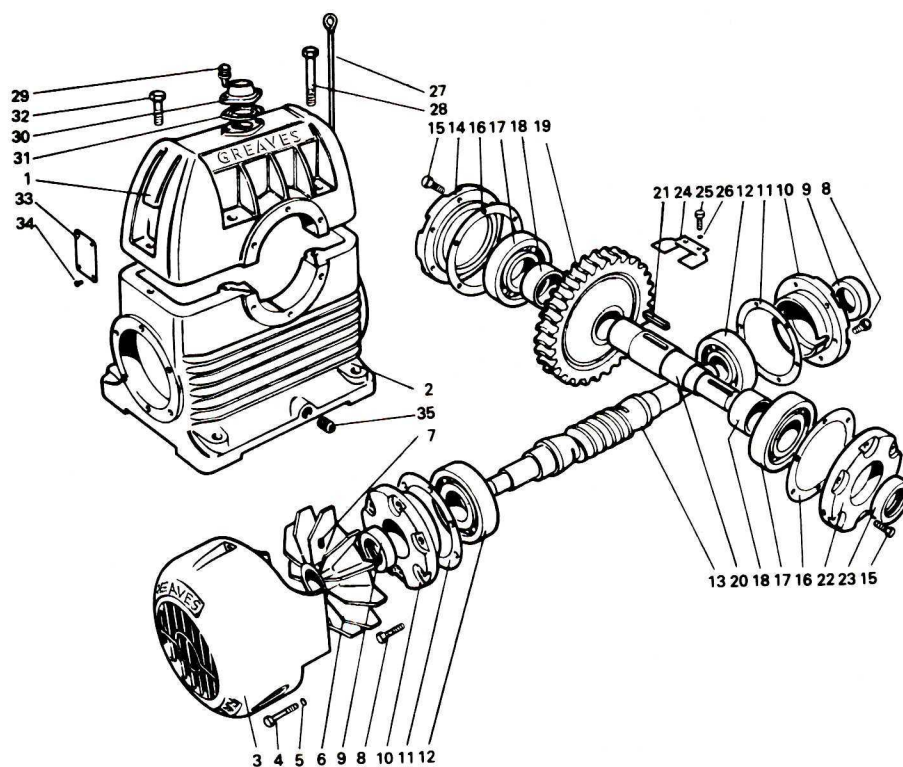

NAMEPLATE DETAILS ESSENTIAL FOR CORRECT PARTS IDENTIFICATION

1	Upper half case	20	Wheelshaft
2	Lower half case	21	Key for wheelshaft
3	Cowl	22	Oil catcher for wheelshaft
4	Bolt for Cowl	23	Oil seal for wheelshaft
5	Spring Washer for cowl bolt	24	Oil scraper
6	Fan	25	Bolt for oil scraper
7	Locking screw for fan	26	Washer for oil scraper bolt
8	Bolt for wormshaft oil catcher	27	Dipstick
9	Oil seal for wormshaft	28	Bolt for case joint
10	Oil catcher for wormshaft	29	Screw for ventilator
11	Shim for wormshaft oil catcher	30	Ventilator
12	Bearing for wormshaft	31	Ventilator packing
13	Wormshaft	32	Bolt for case joint
14	End cover for wheelshaft	33	Nameplate
15	Bolt for wheelshaft covers	34	Rivet for nameplate
16	Shim for wheelshaft covers	35	Drain plug
17	Bearing for wheelshaft	36	Input key
18	Distance piece for wheelshaft	37	Output key
19	Wormwheel		

Note: Item 36 & 37 not shown.

Type 'U' single reduction units

Sizes 1000 to 1700

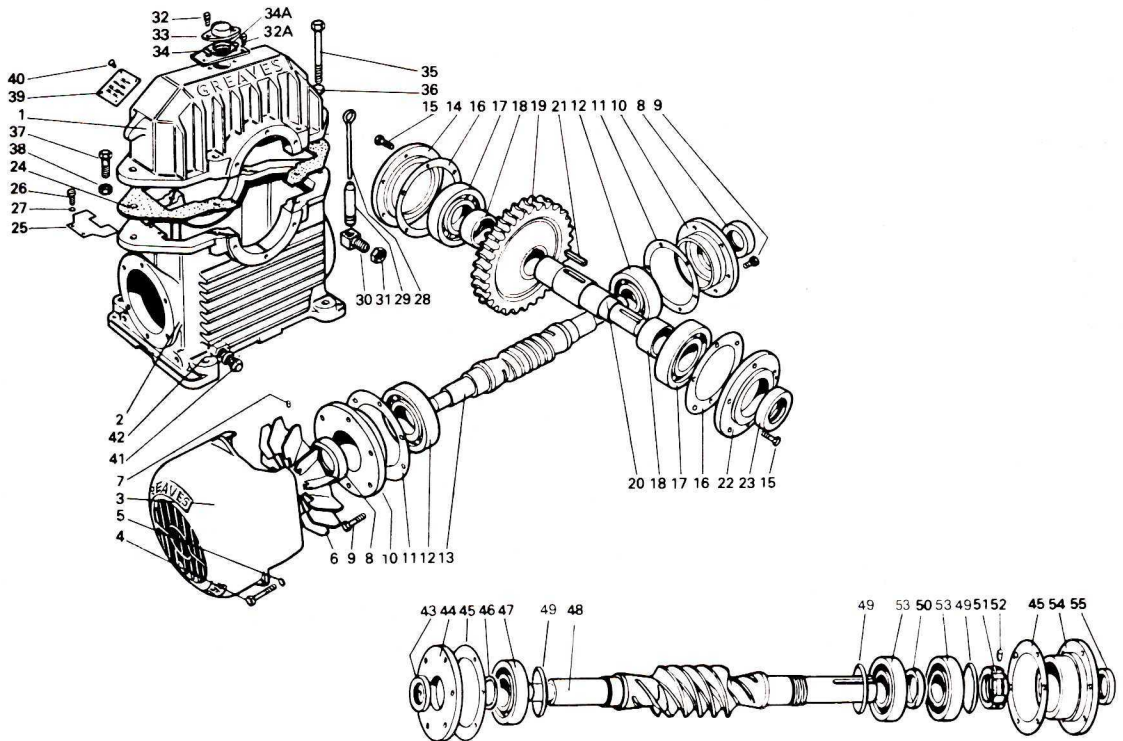

NAMEPLATE DETAILS ESSENTIAL FOR CORRECT PARTS IDENTIFICATION

- | | | | |
|----|--------------------------------|----|---|
| 1 | Upper half case | 30 | Dipstick body |
| 2 | Lower half case | 31 | Dipstick body locknut |
| 3 | Cowl | 32 | Ventilator screw |
| 4 | Bolt for cowl | 33 | Ventilator |
| 5 | Spring washer for cowl bolt | 34 | Ventilator packing |
| 6 | Fan | 35 | Bolt for case joint |
| 7 | Locking screw for fan | 36 | Nut for case joint bolt |
| 8 | Oil seal for wormshaft | 37 | Bolt for case joint |
| 9 | Bolt for wormshaft oil catcher | 38 | Nut for case joint bolt |
| 10 | Oil catcher for wormshaft | 39 | Nameplate |
| 11 | Shim for wormshaft oil catcher | 40 | Rivet for nameplate |
| 12 | Bearing for wormshaft | 41 | Drain plug |
| 13 | Wormshaft | 42 | Fibre washer for drain plug |
| 14 | End cover for wheelshaft | 43 | Oil seals for wormshaft |
| 15 | Bolt for wheelshaft end covers | 44 | Oil catcher for wormshaft-fan end |
| 16 | Shim for wheelshaft covers | 45 | Shim for wormshaft oil catcher |
| 17 | Bearing for wheelshaft | 46 | Circlip for wormshaft |
| 18 | Distance piece for wheelshaft | 47 | Bearing for wormshaft |
| 19 | Wormwheel | 48 | Wormshaft |
| 20 | Wheelshaft | 49 | Distance piece |
| 21 | Key for wheelshaft | 50 | Distance piece - small |
| 22 | Oil catcher for wheelshaft | 51 | Locknut |
| 23 | Oil seal for wheelshaft | 52 | Screw for locknut |
| 24 | Packing for case joint | 53 | Bearing for wormshaft |
| 25 | Oil scraper | 54 | Oil catcher for wormshaft (shaft extension end) |
| 26 | Bolt for oil scraper | 55 | Oil seals for wormshaft |
| 27 | Washer for oil scraper bolt | 56 | Input key |
| 28 | Dipstick | 57 | Output key |
| 29 | Dipstick tube | | |

Note: Items 8, 10-12 are only for unit Sizes U 1000 to U 1400 on wormline. Items 43 to 55 are only for unit Size U 1700 on wormline. Item 56 & 57 not shown.

Type 'O' single reduction units

Sizes 400 to 800

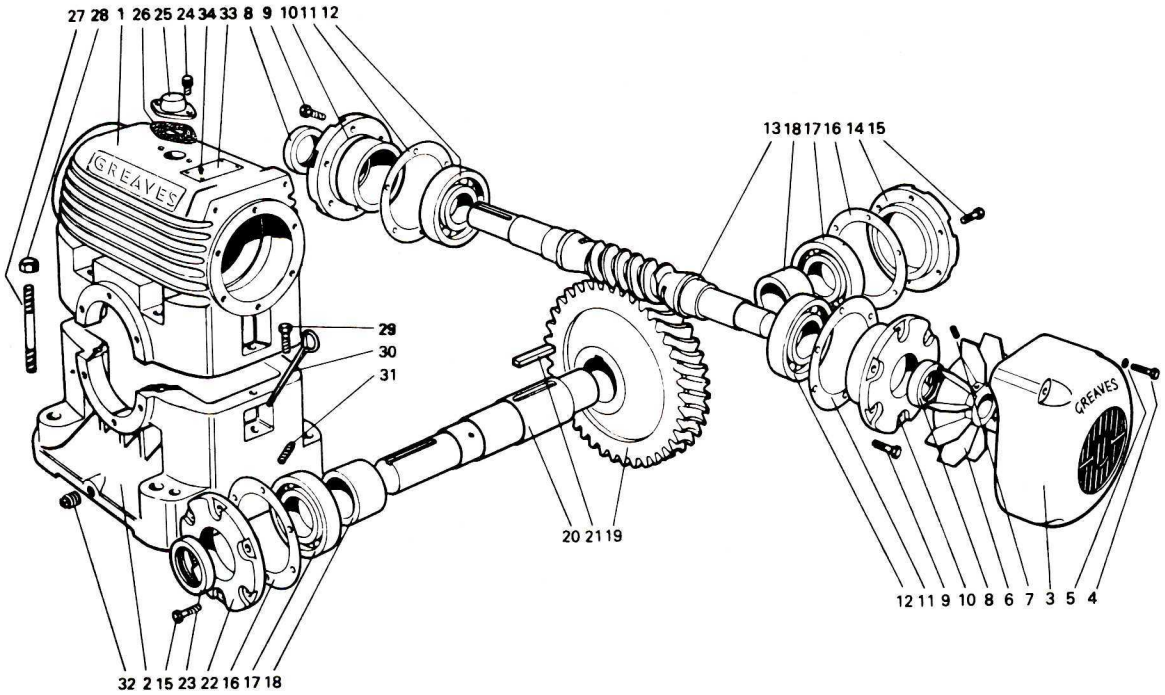

NAMEPLATE DETAILS ESSENTIAL FOR CORRECT PARTS IDENTIFICATION

1	Upper half case	19	Wormwheel
2	Lower half case	20	Wheelshaft
3	Cowl	21	Key for wheelshaft
4	Bolt for Cowl	22	Oil catcher for wheelshaft
5	Spring Washer for cowl bolt	23	Oil seal for wheelshaft
6	Fan	24	Screw for ventilator
7	Locking screw for fan	25	Ventilator
8	Oil seal for wormshaft	26	Ventilator packing
9	Bolt for wormshaft oil catcher	27	Stud for case joint
10	Oil catcher for wormshaft	28	Nut for case joint stud
11	Shim for wormshaft oil catcher	29	Bolt for case joint
12	Bearing for wormshaft	30	Dipstick - not fitted to 400
13	Wormshaft	31	Oil level plug - Size 400 only
14	End cover for wheelshaft	32	Drain plug
15	Bolt for wheelshaft covers	33	Nameplate
16	Shim for wheelshaft covers	34	Rivet for nameplate
17	Bearing for wheelshaft	35	Input key
18	Distance piece for wheelshaft	36	Output key

Note: Eye bolts are fitted to sizes 700 and 800 only. Item 35 & 36 not shown.

Type 'O' single reduction units

Sizes 1000 to 1400

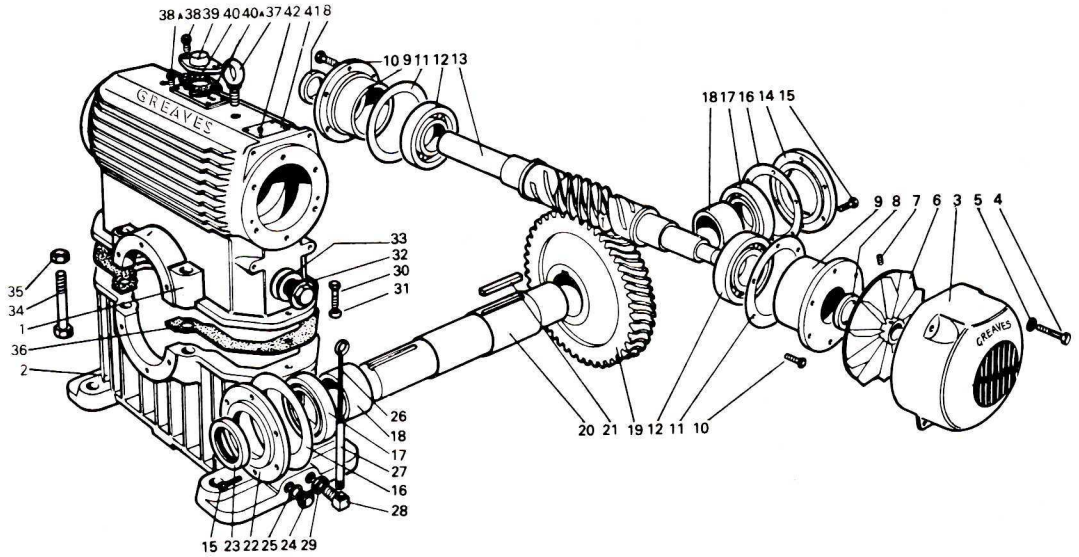

NAMEPLATE DETAILS ESSENTIAL FOR CORRECT PARTS IDENTIFICATION

1	Upper half case	23	Oil seal for wheelshaft
2	Lower half case	24	Drain plug
3	Cowl	25	Fibre washer for drain plug
4	Bolt for Cowl	26	Dipstick
5	Spring Washer for cowl	27	Dipstick tube
6	Fan	28	Dipstick body
7	Locking screw for fan	29	Dipstick body locknut
8	Oil seal for wormshaft	30	Bolt for case joint
9	Oil catcher for wormshaft	31	Nut for case joint bolt
10	Bolt for wormshaft oil catcher	32	Inspection plug
11	Shim for wormshaft oil catcher	33	Fibre washer for inspection plug
12	Bearing for wormshaft	34	Bolt for case joint
13	Wormshaft	35	Nut for case joint bolt
14	End cover for wheelshaft	36	Packing for case joint - not provided for size 1000
15	Bolt for wheelshaft covers	37	Eyebolt
16	Shim for wheelshaft covers	38	Screw for ventilator
17	Bearing for wheelshaft	39	Ventilator
18	Distance piece for wheelshaft	40	Ventilator packing
19	Wormwheel	41	Nameplate
20	Wheelshaft	42	Rivet for nameplate
21	Key for wheelshaft	43	Input key
22	Oil catcher for wheelshaft	44	Output key

Note: Item 43 & 44 not shown.

Type 'V' single reduction units

Sizes 400 to 800

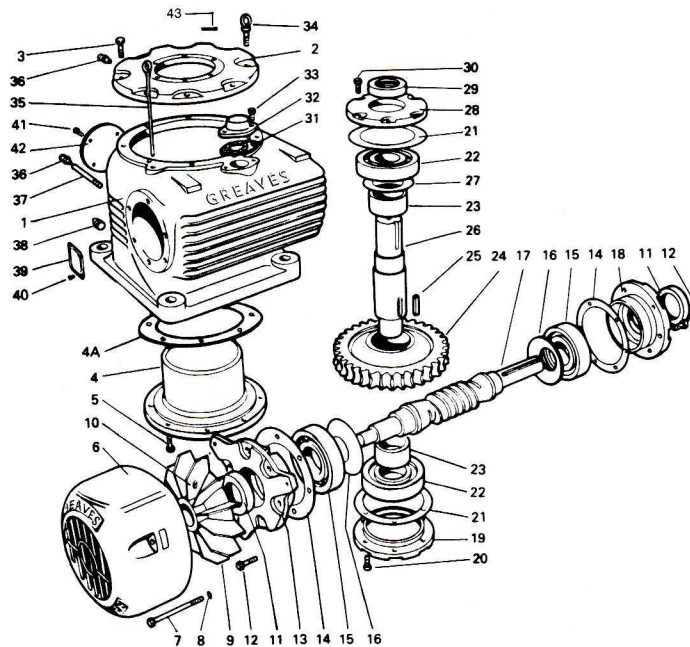

NAMEPLATE DETAILS ESSENTIAL FOR CORRECT PARTS IDENTIFICATION

- | | | | |
|----|---|----|---|
| 1 | Case | 23 | Distance piece for wheelshaft |
| 2 | Upper bearing housing for wheelshaft | 24 | Wormwheel |
| 3 | Bolt for upper bearing housing | 25 | Key for wheelshaft |
| 4 | Lower bearing housing for wheelshaft | 26 | Wheelshaft |
| 4A | Shim for lower bearing housing | 27 | Nilos ring for upper wheelshaft bearing |
| 5 | Bolt for lower bearing housing | 28 | Oil catcher for wheelshaft |
| 6 | Cowl | 29 | Oil seal for wheelshaft |
| 7 | Bolt for cowl | 30 | Bolt for wheelshaft oil catcher |
| 8 | Spring washer for cowl bolt | 31 | Ventilator packing |
| 9 | Fan | 32 | Ventilator |
| 10 | Locking screw for fan | 33 | Screw for ventilator |
| 11 | Oil seal for wormshaft | 34 | Eyebolt - not fitted to unit size 400 |
| 12 | Bolt for wormshaft oil catcher | 35 | Dipstick - this item is oil level plug on Unit Size 400 |
| 13 | Oil catcher for wormshaft - fan end | 36 | Grease nipple for wheelshaft bearings |
| 14 | Shim for wormshaft oil catcher | 37 | Extension pipe for lower grease nipple |
| 15 | Bearing for wormshaft | 38 | Drain plug |
| 16 | Oil flinger for wormshaft | 39 | Nameplate |
| 17 | Wormshaft | 40 | Rivet for nameplate |
| 18 | Oil catcher for wormshaft - shaft extension end | 41 | Bolt for inspection cover |
| 19 | End cover for wheelshaft | 42 | Inspection cover |
| 20 | Bolt for wheelshaft end cover | 43 | Washer (For 700) |
| 21 | Shim for wheelshaft cover | 44 | Input key |
| 22 | Bearing for wheelshaft | 45 | Output key |

Note: Item 44 & 45 not shown.

Type 'V' single reduction units

Sizes 1000 to 1700

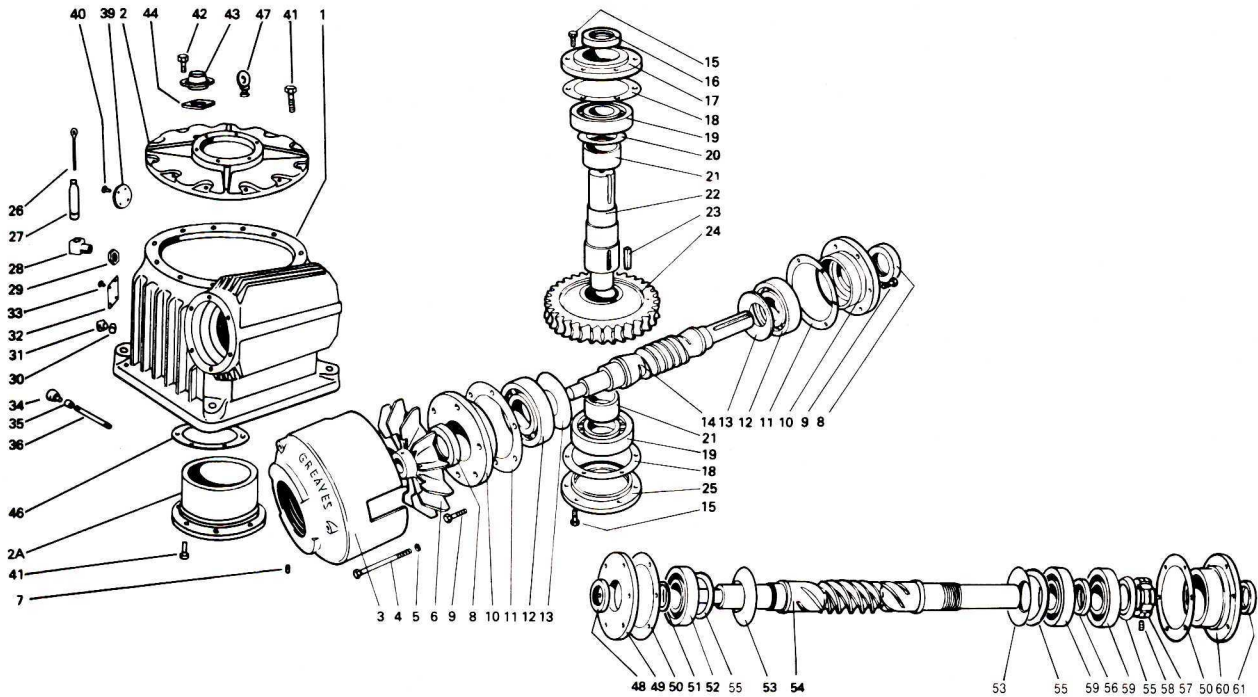

NAMEPLATE DETAILS ESSENTIAL FOR CORRECT PARTS IDENTIFICATION

- | | | | |
|----|---|----|--|
| 1 | Case | 32 | Nameplate |
| 2 | Upper bearing housing | 33 | Rivet for nameplate |
| 2A | Lower bearing housing | 34 | Grease nipple for wheelshaft |
| 3 | Cowl | 35 | Socket for extension piece |
| 4 | Bolt for cowl | 36 | Extension pipe for lower grease nipple |
| 5 | Spring washer for cowl bolt | 39 | Inspection cover |
| 6 | Fan | 40 | Screw for inspection cover |
| 7 | Locking screw for fan | 41 | Bolt for bearing housings |
| 8 | Oil seal for wormshaft | 42 | Screw for ventilator |
| 9 | Bolt for wormshaft oil catcher | 43 | Ventilator |
| 10 | Oil catcher for wormshaft | 44 | Ventilator packing |
| 11 | Shim for wormshaft oil catcher | 45 | Grease lubricator for wheelshaft bearing |
| 12 | Bearing for wormshaft | 46 | Shim for lower bearing housing |
| 13 | Oil flinger for wormshaft | 47 | Eye bolt |
| 14 | Wormshaft | 48 | Oil seals for wormshaft |
| 15 | Bolt for wheelshaft end covers | 49 | End cover for wormshaft-fan end |
| 16 | Oil seal for wheelshaft | 50 | Shim for wormshaft oil catcher |
| 17 | Oil catcher for wheelshaft | 51 | Circlip for wormshaft |
| 18 | Shim for wheelshaft | 52 | Bearing for wormshaft |
| 19 | Bearing for wheelshaft | 53 | Oil flinger for wormshaft |
| 20 | Nilos ring for upper wheelshaft bearing | 54 | Wormshaft |
| 21 | Distance piece for wheelshaft | 55 | Distance piece |
| 22 | Wheelshaft | 56 | Distance piece - small |
| 23 | Key for wheelshaft | 57 | Locknut |
| 24 | Wormwheel | 58 | Screw for locknut |
| 25 | End cover for wheelshaft | 59 | Bearing for wormshaft |
| 26 | Dipstick | 60 | Oil catcher for wormshaft |
| 27 | Dipstick tube | 61 | Oil seals for wormshaft |
| 28 | Dipstick body | 62 | Input key |
| 29 | Dipstick body locknut | 63 | Output key |
| 30 | Fibre washer for drain plug | | |
| 31 | Drain Plug | | |

Note: Items 1 to 47 are only for unit Sizes V1000 to V1400. Items 48 to 61 are only for unit Size V1700
Item 62 & 63 not shown.

Adaptable double reduction units

Sizes 162 to 337

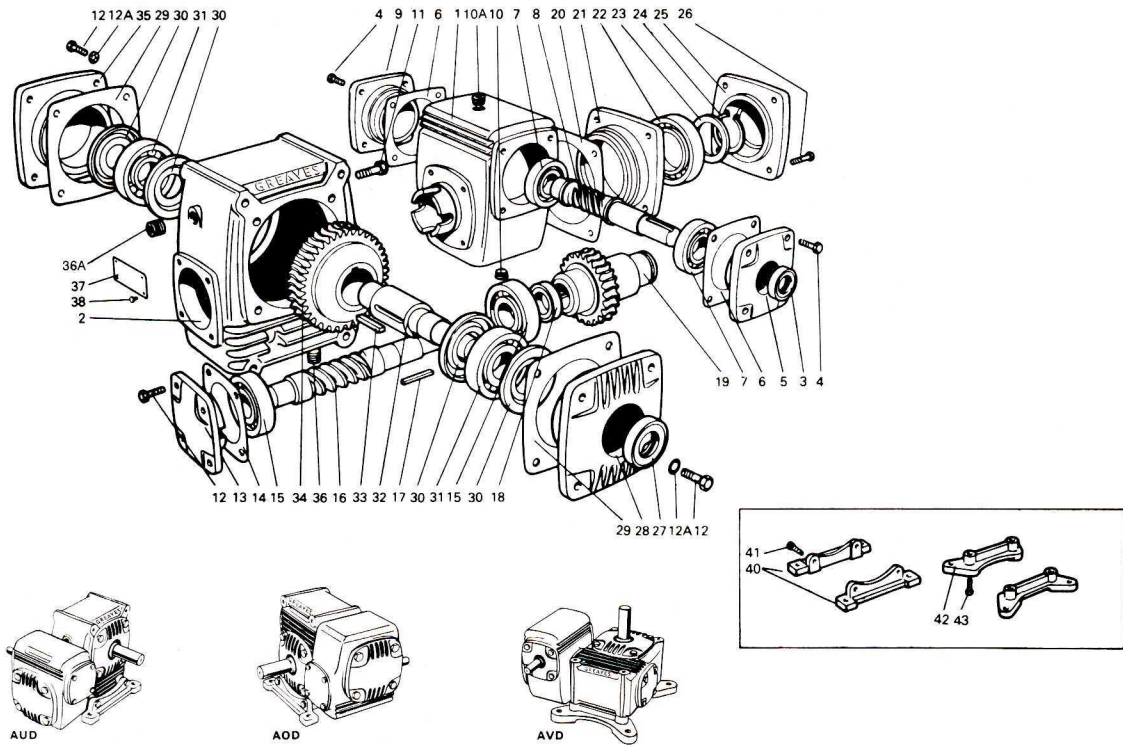

NAMEPLATE DETAILS ESSENTIAL FOR CORRECT PARTS IDENTIFICATION

- | | | | |
|-----|--|-----|--|
| 1 | 1st reduction case | 22 | Bearing for 1st reduction wormwheel |
| 2 | 2nd reduction case | 23 | Distance piece for 1st reduction wormwheel |
| 3 | Oil seal for 1st reduction wormshaft | 24 | Circlip for 1st reduction wormwheel |
| 4 | Bolt for 1st reduction wormshaft covers | 25 | End cover for 1st reduction wormwheel |
| 5 | Oil catcher for 1st reduction wormshaft | 26 | Bolt for 1st reduction wormwheel end cover |
| 6 | Shim for 1st reduction wormshaft covers | 27 | Oil seal for 2nd reduction wheelshaft |
| 7 | Bearing for 1st reduction wormshaft | 28 | Oil catcher for 2nd reduction wheelshaft |
| 8 | 1st reduction wormshaft | 29 | Shim for 2nd reduction wheelshaft covers |
| 9 | End cover for 1st reduction wormshaft | 30 | Nilos'ring |
| 10 | Plug for 1st reduction case | 31 | Bearing for 2nd reduction wheelshaft |
| 10A | Breather for 1st reduction case | 32 | 2nd reduction wheelshaft |
| 11 | Bolt for 2nd reduction case | 33 | Key for 2nd reduction wheelshaft |
| 12 | Bolt for 2nd reduction wormshaft end cover | 34 | 2nd reduction wormwheel |
| 12A | Copper washer for 2nd reduction wheelshaft covers on size 162 only | 35 | 2nd reduction wheelshaft end cover |
| 13 | End cover for 2nd reduction wormshaft | 36 | Plug for 2nd reduction case |
| 14 | Shim for 2nd reduction wormshaft end cover | 36A | Breather |
| 15 | Bearing for 2nd reduction wormshaft | 37 | Nameplate |
| 16 | 2nd reduction wormshaft | 38 | Rivet for nameplate |
| 17 | Key for 2nd reduction wormshaft | 40 | No. 1 foot |
| 18 | Oil seal for 2nd reduction wormshaft | 41 | Bolt for No. 1 foot |
| 19 | 1st reduction worm wheel | 42 | No. 2 foot |
| 20 | Shim for 1st reduction wormwheel bearing housing | 43 | Bolt for No. 2 foot |
| 21 | 1st reduction wormwheel bearing housing | 44 | Input key |
| | | 45 | Output key |

Note: Item 44 & 45 not shown.

Type 'UD' double reduction units

Sizes 400 to 1700

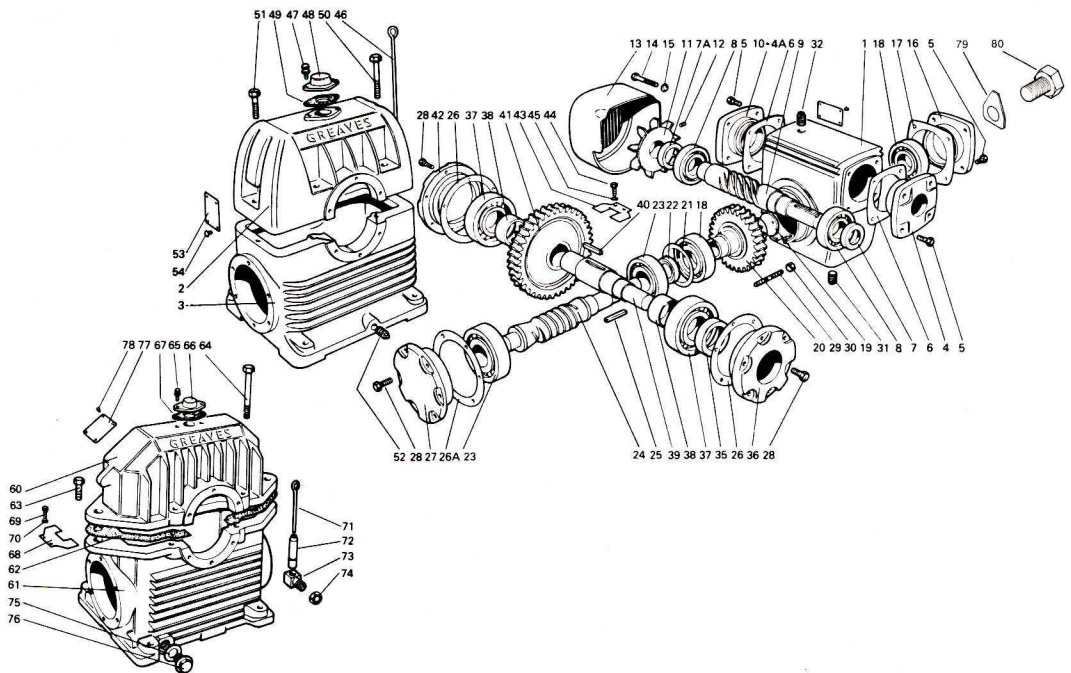

NAMEPLATE DETAILS ESSENTIAL FOR CORRECT PARTS IDENTIFICATION

1	1st reduction case	23	Bearing for 2nd reduction wormshaft	51	Bolt for 2nd reduction case joint
2	Upper half 2nd reduction case	24	2nd reduction wormshaft	52	Drain plug
3	Lower half 2nd reduction case	25	Key for 2nd reduction wormshaft	53	Nameplate
4	Oil catcher for 1st reduction wormshaft	26	Shim for 2nd reduction wheelshaft covers	54	Rivet for nameplate
4A	Oil catcher for 1st reduction wormshaft (unit sizes 800 to 1400)	26A	Shim for 2nd reduction wormshaft end cover	60	Upper half, 2nd reduction case
5	Bolt for oil catcher	27	End cover for 2nd reduction wormshaft	61	Lower half, 2nd reduction case
6	Shim for 1st reduction wormshaft oil catcher	28	Bolt for 2nd reduction covers	62	Packing for case joint - not provided for size 1000
7	Oil seal for 1st reduction wormshaft	29	Stud for 1st reduction case	63	Bolt for case joint
7A	Oil seal for 1st reduction wormshaft (unit sizes 800 to 1400)	30	Nut for stud	64	Bolt for case joint
8	Bearing for 1st reduction wormshaft	31	Drain plug for 1st reduction case	65	Screw for ventilator
9	1st reduction wormshaft	32	Breather plug for 1st reduction case	66	Ventilator
10	End cover for 1st reduction wormshaft (unit sizes 400 to 700)	35	Oil seal for 2nd reduction wheelshaft	67	Ventilator packing
11	Fan (unit sizes 800 to 1400)	36	Oil catcher for 2nd reduction wheelshaft	68	Oil scraper
12	Locking screw for fan (unit sizes 800 to 1400)	37	Bearing for 2nd reduction wheelshaft	69	Bolt for oil scraper
13	Cowl (unit sizes 800 to 1400)	38	Distance piece for 2nd reduction wheelshaft	70	Washer for oil scraper bolt
14	Bolt for cowl (unit sizes 800 to 1400)	39	2nd reduction wheelshaft	71	Dipstick
15	Spring washer for cowl bolt (unit sizes 800 to 1400)	40	Key for 2nd reduction wheelshaft	72	Dipstick tube
16	1st reduction wormwheel bearing housing	41	2nd reduction wormwheel	73	Dipstick body
17	Shim for 1st reduction wormwheel bearing housing	42	End cover for 2nd reduction wheelshaft	74	Locknut for dipstick body
18	Bearing for 1st reduction wormwheel	43	Oil scraper	75	Fibre washer for drain plug
19	Expanding plug for 1st reduction wormwheel	44	Bolt for oil scraper	76	Drain plug
20	1st reduction wormwheel	45	Washer for oil scraper bolt	77	Nameplate
21	Shim for 1st reduction wormwheel	46	Dipstick	78	Rivet for nameplate
22	Oil seal for 2nd reduction wormshaft	47	Screw for ventilator	79	Key retaining plate
		48	Ventilator	80	Bolt
		49	Ventilator packing	81	Input key
		50	Bolt for 2nd reduction case joint	82	Output key

Refer page 6 for the following additional parts for UD 1700: Circlip (46), Additional wormshaft bearing (47), Distance piece (49), Distance piece (50), locknut (51), Screw for Locknut (52), Bearing for wormshaft (53). Not shown in above sketch.

Note: Item 19 is only for unit sizes UD 400 to UD 800, Item 79 & 80 are only for unit sizes UD 1000 to UD 1700. Item 81 & 82 not shown.

The 2nd reduction case of unit sizes 1000 to 1700 are of a design different to that of sizes 400 to 800. Items 60 to 78 replace items 2, 3, 43 & 54.

Type 'OD' double reduction units

Sizes 400 to 1400

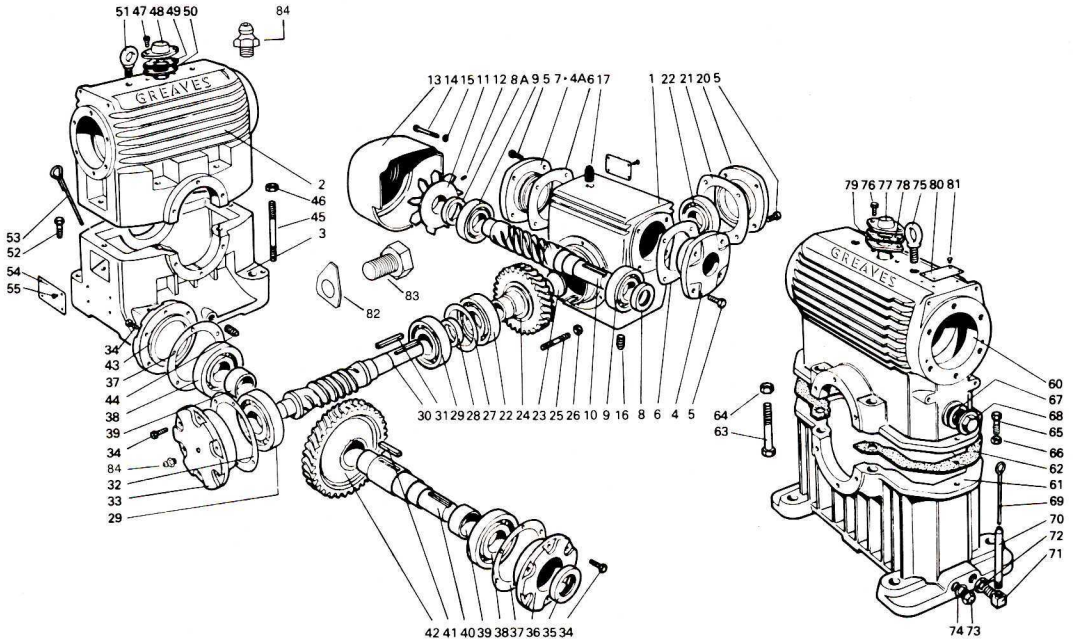

NAMEPLATE DETAILS ESSENTIAL FOR CORRECT PARTS IDENTIFICATION

1	1st reduction case	26	Nut for stud	51	Eyebolt (unit sizes 700 and 800)
2	Upper half 2nd reduction case	27	Shim for 1st reduction wormwheel	52	Bolt for 2nd reduction case joint
3	Lower half 2nd reduction case	28	Oil seal for 2nd reduction wormshaft	53	Dipstick (unit size 400 is fitted with oil level plug)
4	Oil catcher for 1st reduction wormshaft	29	Bearing for 2nd reduction wormshaft	54	Nameplate
4A	Oil catcher for 1st reduction wormshaft (unit sizes 800 to 1400)	30	2nd reduction wormshaft	55	Rivet for nameplate
5	Bolt for oil catcher	31	Key for 2nd reduction wormshaft	60	Upper half, 2nd reduction case
6	Shim for 1st reduction wormshaft oil catcher	32	Shim for 2nd reduction wormshaft end cover	61	Lower half, 2nd reduction case
7	End cover for 1st reduction wormshaft (unit sizes 400 to 700)	33	End cover for 2nd reduction wormshaft	62	Packing for case joint - not provided for size 1000
8	Oil seal for 1st reduction wormshaft	34	Bolt for 2nd reduction wormshaft end cover	63	Bolt for case joint
8A	Oil seal for 1st reduction wormshaft (unit sizes 800 to 1400)	35	Oil seal for 2nd reduction wheelshaft	64	Nut for case joint bolt
9	Bearing for 1st reduction wormshaft	36	Oil catcher for 2nd reduction wheelshaft	65	Bolt for case joint
10	1st reduction wormshaft	37	Shim for 2nd reduction wheelshaft covers	66	Nut for case joint bolt
11	Fan (unit sizes 800 to 1400)	38	Bearing for 2nd reduction wheelshaft	67	Fibre washer for inspection plug
12	Locking screw for fan (unit sizes 800 to 1400)	39	Distance piece for 2nd reduction wheelshaft	68	Inspection plug
13	Cowl (unit sizes 800 to 1400)	40	2nd reduction wheelshaft	69	Dipstick
14	Bolt for cowl (unit sizes 800 to 1400)	41	Key for 2nd reduction wheelshaft	70	Dipstick tube
15	Spring washer for cowl bolt (unit sizes 800 to 1400)	42	2nd reduction wormwheel	71	Dipstick body
16	Drain plug for 1st reduction case	43	End cover for 2nd reduction wheelshaft	72	Locknut for dipstick body
17	Breather plug for 1st reduction case	44	Drain plug for 2nd reduction case	73	Drain plug
20	1st reduction wormwheel bearing housing	45	Stud for 2nd reduction case joint	74	Fibre washer for drain plug
21	Shim for 1st reduction wormwheel bearing housing	46	Nut for Stud 2nd reduction case	75	Eyebolt
22	Bearing for 1st reduction wormwheel	47	Screw for ventilator	76	Screw for ventilator
23	Expanding plug for 1st reduction wormwheel	48	Ventilator for 2nd reduction case	77	Ventilator
24	1st reduction wormwheel	49	Ventilator packing	78	Packing for Ventilator
25	Stud for 1st reduction case	50	Oil scraper	79	Oil scraper
				80	Nameplate
				81	Rivet for nameplate
				82	Key retaining plate
				83	Bolt
				84	Grease Nipple
				85	Nilos Ring (not shown in above sketch)
				86	Input key
				87	Output key

Note: Item 23 is only for unit sizes OD 400 to OD 800, Item 82 & 83 are only for unit sizes OD 1000 to OD 1400. Item 85 to 87 not shown.

The 2nd reduction case of unit sizes 1000 to 1400 are of a design different to that of sizes 400 to 800. Items 60 to 81 replace Items 2, 3, 44 & 55.

Type 'VD' double reduction units

Sizes 400 to 1700

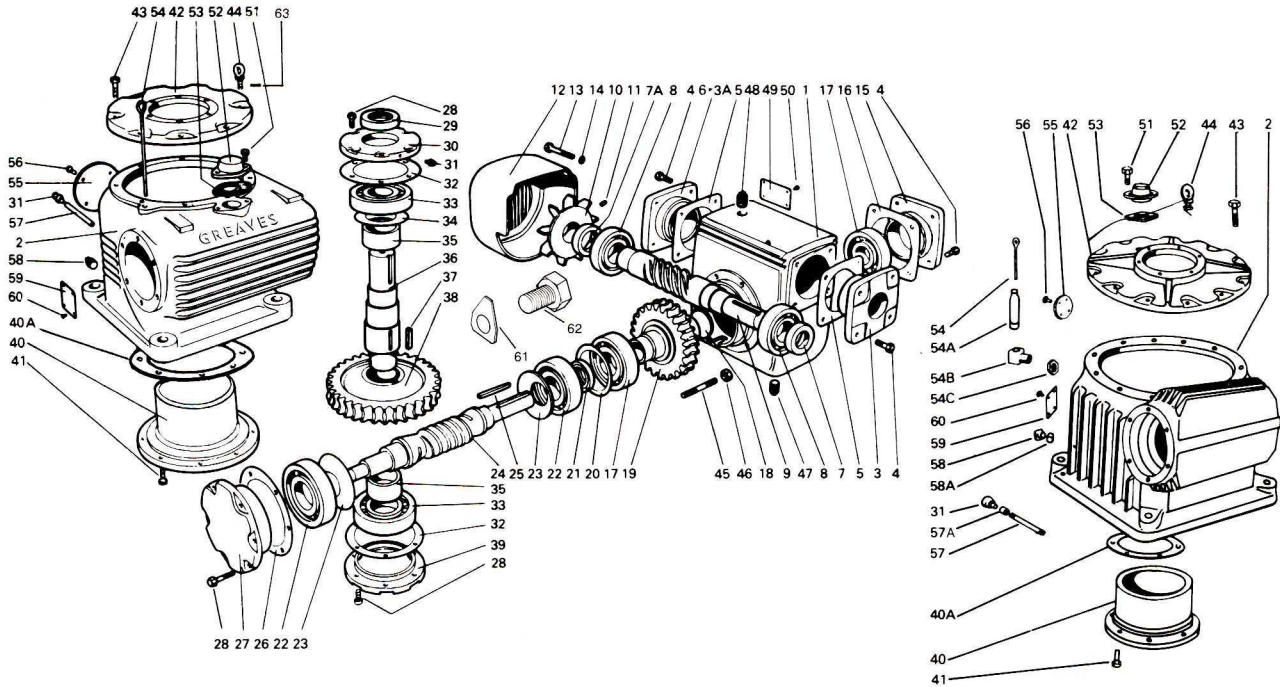

NAMEPLATE DETAILS ESSENTIAL FOR CORRECT PARTS IDENTIFICATION

1	1st reduction case	wormwheel	42	Upper bearing housing for 2nd reduction wheelshaft	
2	2nd reduction case	22	Bearing for 2nd reduction wormshaft	43	Bolt for 2nd reduction upper bearing housing
3	Oil catcher for 1st reduction wormshaft	23	Oil flinger	44	Eye bolt
3A	Oil catcher for 1st reduction wormshaft (unit sizes 800 to 1400)	24	2nd reduction wormshaft	45	Stud for 1st reduction case
4	Bolt for 1st reduction wormwheel bearing housing	25	Key for 2nd reduction wormshaft	46	Nut for 1st reduction case stud
5	Shim for 1st reduction wormshaft oil catcher	26	Shim for 2nd reduction end cover	47	Drain plug for 1st reduction case
6	End cover for 1st reduction wormshaft (unit sizes 400 to 700)	27	End cover for 2nd reduction wormshaft	48	Breather plug
7	Oil seal for 1st reduction wormshaft	28	Bolt for 2nd reduction end cover	51	Screw for ventilator
7A	Oil seal for 1st reduction wormshaft (unit sizes 800 to 1400)	29	Oil seal for 2nd reduction wheelshaft	52	Ventilator
8	Bearing for 1st reduction wormshaft	30	2nd reduction wheelshaft oil catcher	53	Ventilator packing
9	1st reduction wormshaft	31	Grease nipple for 2nd reduction wheelshaft bearing	54	Dipstick
10	Fan (unit sizes 800 to 1400)	32	Shim for 2nd reduction wheelshaft	54A	Dipstick tube
11	Locking screw for fan (unit sizes 800 to 1400)	33	Bearing for 2nd reduction wheelshaft	54B	Dipstick body
12	Cowl (unit sizes 800 to 1400)	34	Nilos Ring for 2nd reduction wheelshaft bearing	54C	Locknut for dipstick body
13	Bolt for cowl (unit sizes 800 to 1400)	35	Distance piece for 2nd reduction wheelshaft	55	Inspection cover
14	Spring washer for cowl bolt (unit sizes 800 to 1400)	36	2nd reduction wheelshaft	56	Bolt for inspection cover
15	1st reduction wormwheel bearing housing	37	Key for 2nd reduction wormwheel	57	Extension pipe for lower grease nipple
16	Shim for 1st reduction wormwheel bearing housing	38	2nd reduction wormwheel	57A	Socket for lower grease nipple
17	Bearing for 1st reduction wormwheel	39	End cover for 2nd reduction wheelshaft	58	Drain plug for 2nd reduction case
18	Expanding plug for 1st reduction wormwheel	40	Lower bearing housing for 2nd reduction wheelshaft	58A	Fibre washer for drain plug
19	1st reduction wormwheel	40A	Shim for lower bearing housing	59	Nameplate
20	Shim for 1st reduction wormwheel	41	Bolt for 2nd reduction lower bearing housing	60	Rivet for nameplate
21	Oil seal for 1st reduction			61	Key retaining plate
				62	Bolt
				63	Washer (For 700)
				64	Input key
				65	Out key

Refer page 10 for the following additional parts for VD 1700: Circlip (51), Additional wormshaft bearing (52), Distance piece (55), Distance piece (56), locknut (57), Screw for Locknut (58), Bearing for wormshaft (59). Not shown in above sketch.

Note: Item 18 is only for unit sizes VD 400 to VD 800, Item 61 & 62 are only for sizes VD 1000 to VD 1700. Parts 2, 40 to 44, 51 to 60 applicable for Unit sizes 1000 to 1700 are shown on right portion of the sketch. Item 64 & 65 not shown.

Greaves lift units (Sleeve bearings on input shaft)

Type SLA

Sizes 500 to 1200

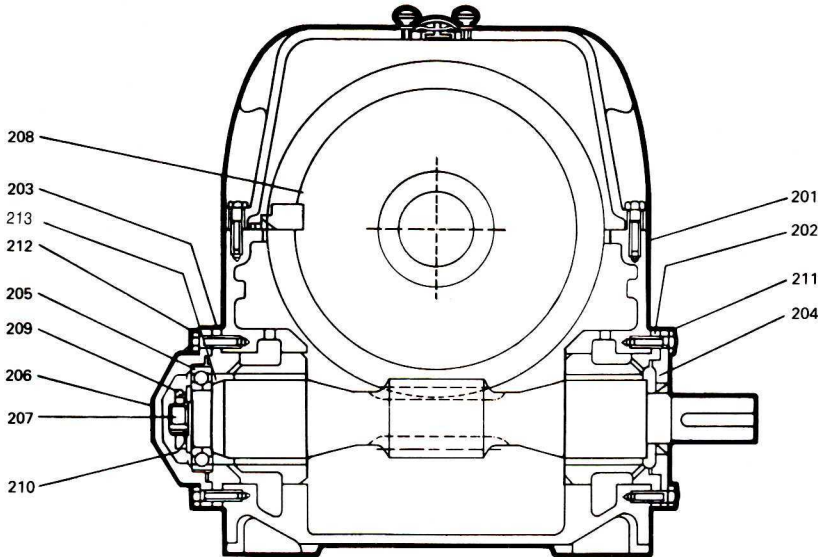

Note : Item 213 is only for unit sizes 700 and 800 and not shown in above sketch.

Parts shown above are substitute/additional parts for the sleeve bearing feature. All other parts are common to standard unit of respective size.

201 Case

202 Bearing housing with white metal/bronze sleeve-driving end

203 Bearing housing with white metal/bronze sleeve-closed end

204 Oil Seal housing

205 Duplex bearing

206 End cover

207 Input shaft with sleeves

208 Wormwheel

209 Locknut

210 Lockwasher

211 Bolt for oil seal housing

212 Bolt for end cover

213 Spacer

Greaves standard duty stirrer units

Type STR

Sizes 400 to 1700

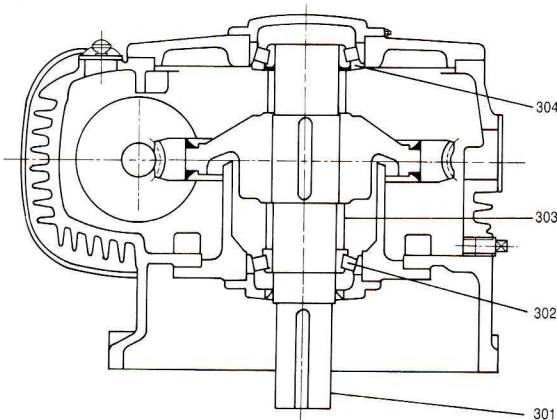

301 Output shaft

302 Roller bearing

303 Distance piece

304 Nilos ring

See page 17 for motor plate parts.

Parts shown above are substitute/additional parts. All other parts are common to standard V type unit of respective size.

Greaves heavy duty stirrer units

Type HDS

Sizes 400 to 1700

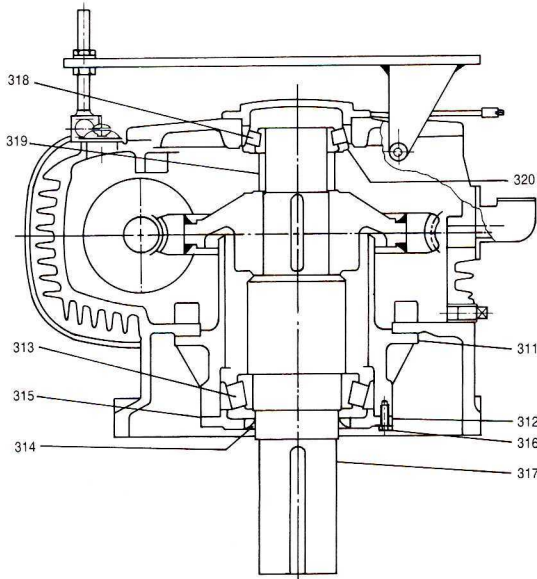

- 311 Lower bearing housing
- 312 Oil seal housing
- 313 Lower bearing
- 314 Oil seal
- 315 Shim for oil seal housing
- 316 Bolt for oil seal housing
- 317 Output shaft
- 318 Upper bearing
- 319 Distance piece
- 320 Nilos ring

Parts shown above are substitute/ additional parts. All other parts are common to standard V type unit of respective size.

NAMEPLATE DETAILS ESSENTIAL FOR CORRECT PARTS IDENTIFICATION.

Hinged motor plates for stirrer units

Sizes 400 to 1700

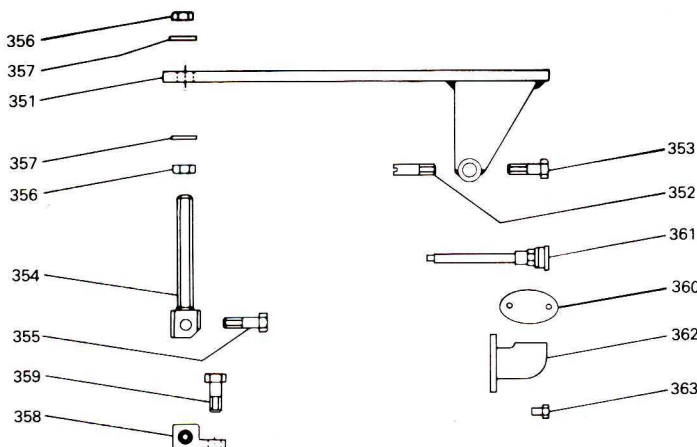

- 351 Motor plate
- 352 Hinge pin for motor plate
- 353 Bolt for motor plate
- 354 Eye bolt
- 355 Bolt for eye bolt
- 356 Nut for eye bolt
- 357 Washer for eye bolt
- 358 Support bracket
- 359 Bolt for support bracket
- 360 Cover plate
- 361 Lubricator extension
- 362 Oil filler
- 363 Bolt for oil filler.

Case and cowl of sizes 400-800 and upper bearing housing of Sizes 1000-1700 are modified for fitting motor plate. Quote item Numbers 371, 372, 373 for these modified components respectively.

Greaves cooling tower units

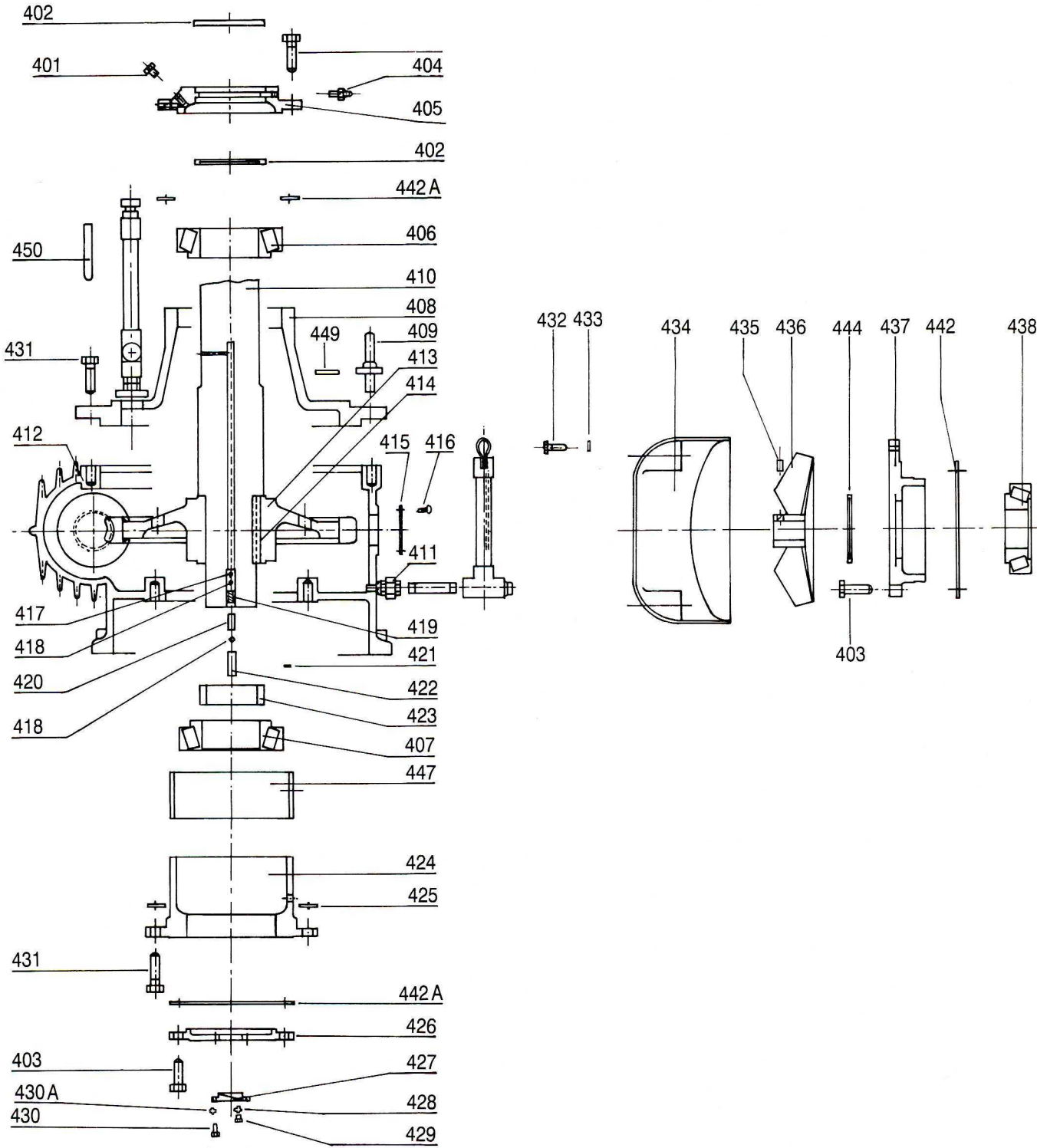

Type CT

Sizes 400 to 1400

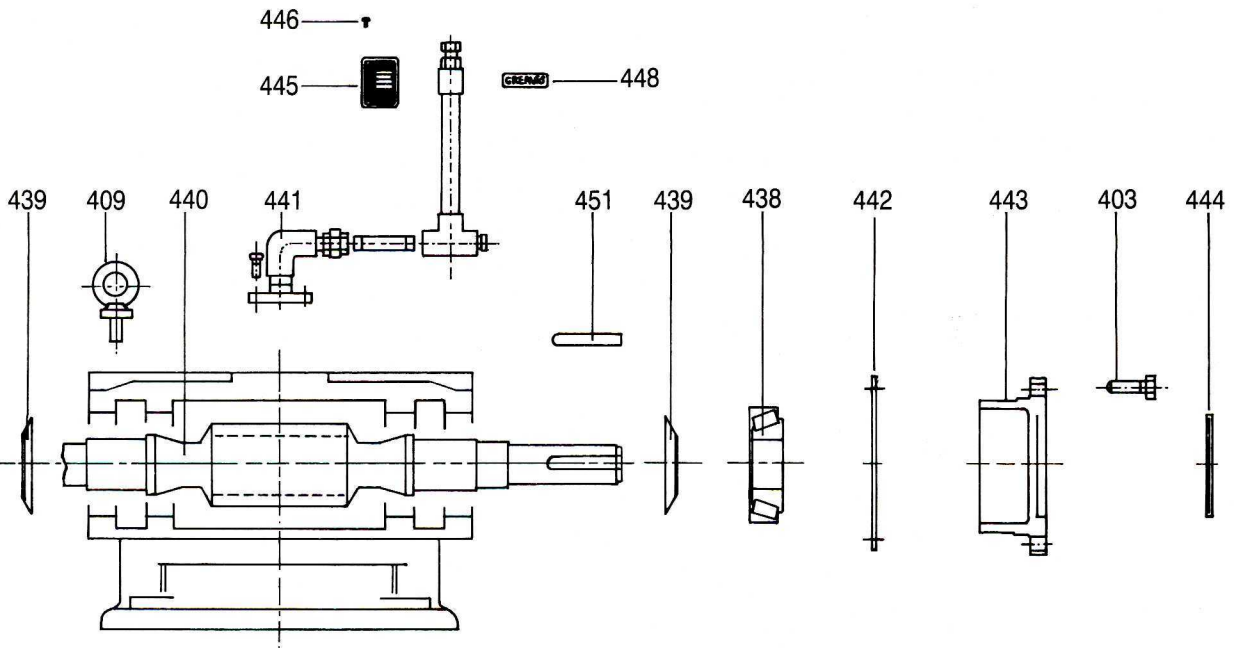

- | | | | |
|------|---------------------------------|------|------------------------------|
| 401 | Plug | 428 | Fibre washer for plug |
| 402 | Oil seal for wheelshaft | 429 | Plug |
| 403 | Bolt for wheelshaft covers | 430 | Bolt for swash plate |
| 404 | Grease nipple | 430A | Washer |
| 405 | Oil seal housing | 431 | Bolt for bearing housing |
| 406 | Bearing for wheelshaft-top | 432 | Bolt for cowl |
| 407 | Bearing for wheelshaft - bottom | 433 | Spring washer |
| 408 | Upper bearing housing | 434 | Cowl |
| 409 | Eye bolt | 435 | Locking screw for fan |
| 410 | Wheelshaft | 436 | Fan |
| 411 | Oil filler/drain connection | 437 | Oil catcher for wormshaft |
| 411A | Oil level plug (NOT SHOWN) | 438 | Bearing for wormshaft |
| 412 | Case | 439 | Oil flinger for wormshaft |
| 413 | Wormwheel | 440 | Wormshaft |
| 414 | Key for wormwheel | 441 | Ventilator connection |
| 415 | Inspection cover | 442 | Shim for wormshaft covers |
| 416 | Bolt for inspection cover | 442A | Shim for wheelshaftcover |
| 417 | Ball retainer | 443 | Oil catcher for wormshaft |
| 418 | Ball | 444 | Oil seal for wormshaft |
| 419 | Ball seat | 445 | Name plate |
| 420 | Spring | 446 | Rivet for name plate |
| 421 | Pin | 447 | Oil strainer (1000 To 1400) |
| 422 | Plunger | 448 | Brand nameplate (400 to 700) |
| 423 | Distance piece | 449 | Washer for 700 |
| 424 | Lower bearing housing | 450 | Key - wheelshaft |
| 425 | Shim | 451 | Key - wormshaft |
| 426 | End cover for wheelshaft | | |
| 427 | Swash plate | | |

NAMEPLATE DETAILS ESSENTIAL FOR CORRECT PARTS IDENTIFICATION

Greaves cooling tower units

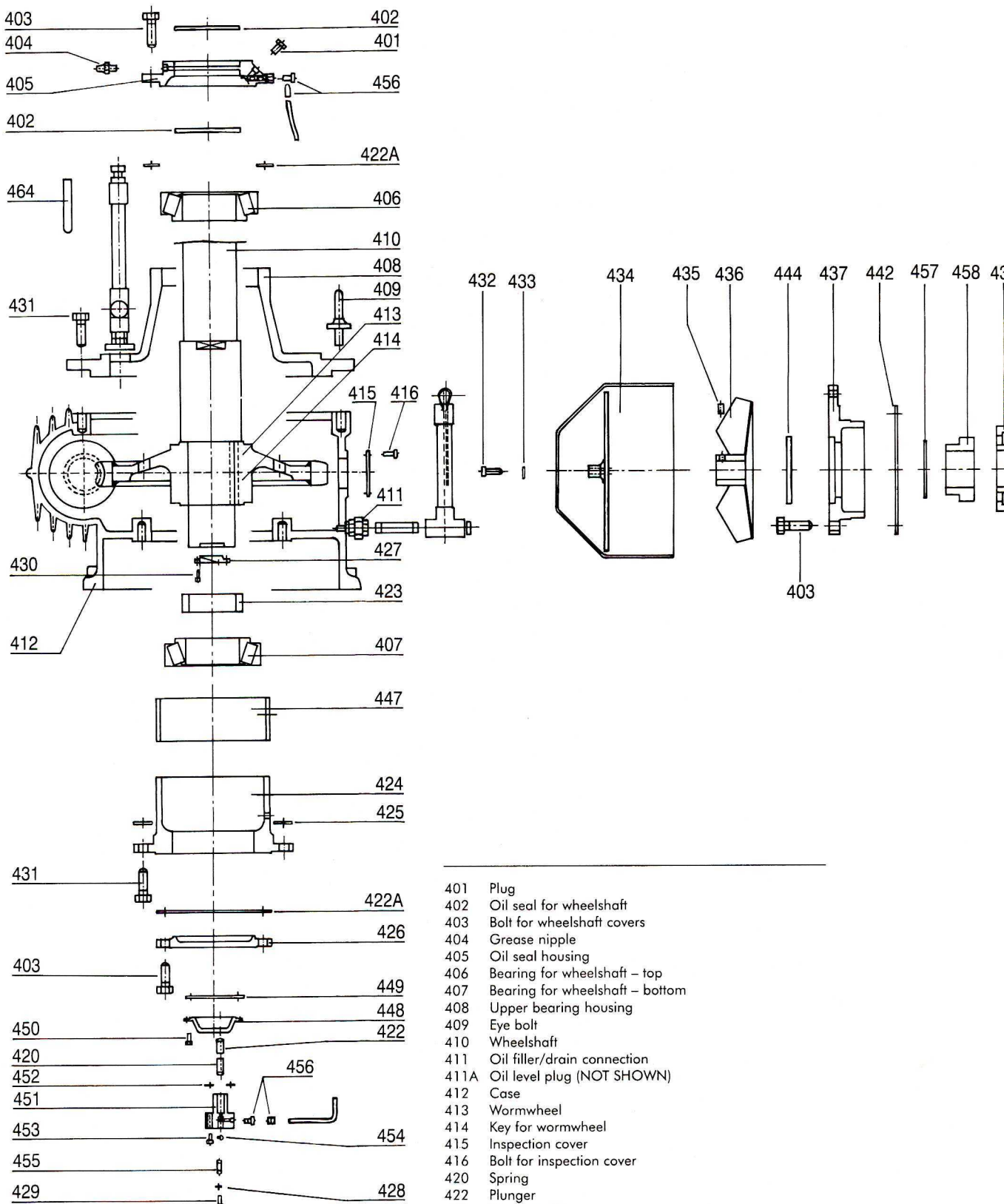

- 401 Plug
- 402 Oil seal for wheelshaft
- 403 Bolt for wheelshaft covers
- 404 Grease nipple
- 405 Oil seal housing
- 406 Bearing for wheelshaft - top
- 407 Bearing for wheelshaft - bottom
- 408 Upper bearing housing
- 409 Eye bolt
- 410 Wheelshaft
- 411 Oil filler/drain connection
- 411A Oil level plug (NOT SHOWN)
- 412 Case
- 413 Wormwheel
- 414 Key for wormwheel
- 415 Inspection cover
- 416 Bolt for inspection cover
- 420 Spring
- 422 Plunger
- 423 Distance piece
- 424 Lower bearing housing
- 425 Shim

Type CT

Sizes 1700

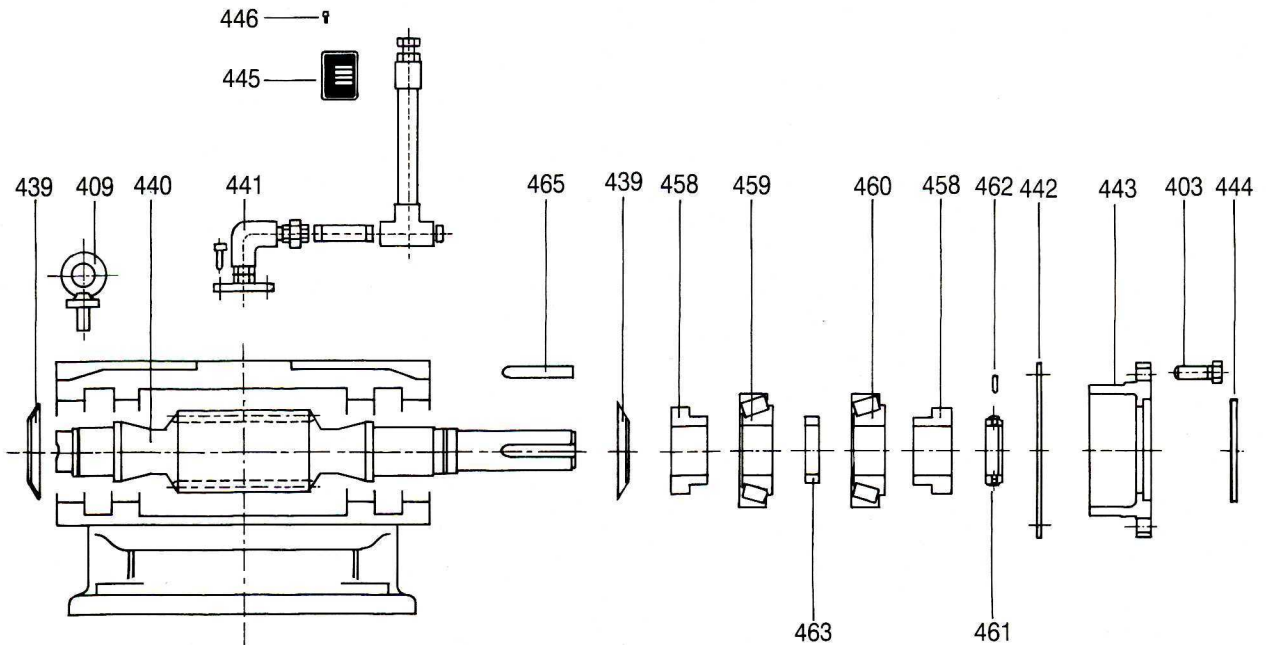

426	End cover for wheelshaft	446	Rivet for name plate
427	Swash plate	447	Oil strainer
428	Fibre washer for plug	448	Pump housing
429	Plug	449	Gasket – pump cover
430	Bolt for swash plate	450	Set screw – pump cover
431	Bolt for bearing housing	451	Plunger body
432	Bolt for cowl	452	Shim – plunger body
433	Spring washer	453	Cap screw – plunger body
434	Cowl	454	Ball
435	Locking screw for fan	455	Spring
436	Fan	456	Pipe assembly for pump
437	Oil catcher for wormshaft	457	Circlip – wormshaft
438	Bearing for wormshaft	458	Distance piece
439	Oil flinger for wormshaft	459	Bearing for wormshaft
440	Wormshaft	460	Bearing for wormshaft
441	Ventilator connection	461	Lock nut
442	Shim for wormshaft covers	462	Screw for lock nut
442A	Shim for wheelshaft cover	463	Distance piece
443	Oil catcher for wormshaft	464	Key – wheelshaft
444	Oil seal for wormshaft	465	Key – wormshaft
445	Name plate		

Greaves gearboxes with special features

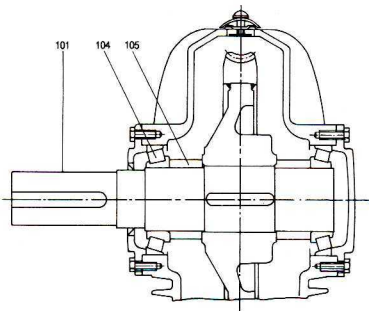

One wider bearing
on output shaft
Refer-D-15-1

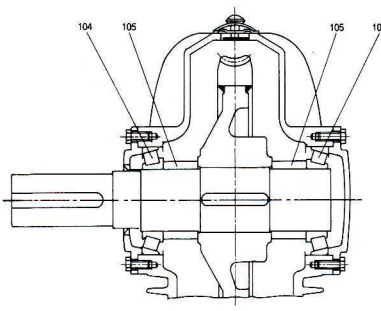

Two wider bearings
on output shaft
Refer-D-15-2

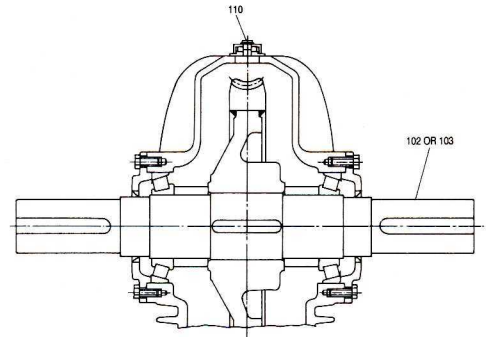

Dust proof ventilator
Double extended output shaft
Refer-D-15-3

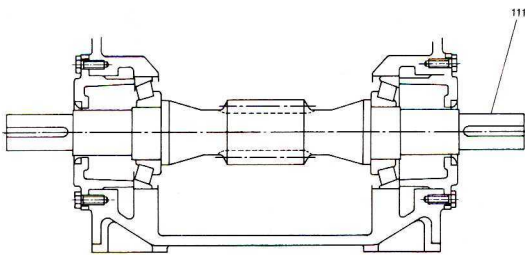

Double extended input
shaft for unit without fan
Refer-D-15-4

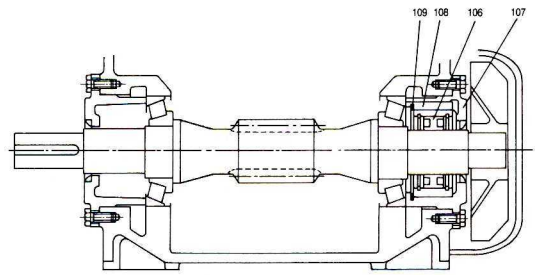

Unit fitted with
roller holdback
Refer-D-15-5

- 101 Output shaft of high tensile steel
- 102 Output shaft extended on both sides-standard material
- 103 Output shaft extended on both sides-high tensile steel
- 104 Wider bearing on output shaft
- 105 Narrow distance piece for use with item 104
- 106 Roller holdback sub-assembly - for Sizes 400 upwards
- 107 Housing for roller holdback sub-assembly
- 108 Key for holdback sub-assembly
- 109 Circlip for holdback sub-assembly
- 110 Dustproof ventilator-for Sizes 400 upwards
- 111 Wormshaft extended on both sides.

Parts shown above are substitute/additional parts for the required feature All other parts are common to standard unit of respective size and type.

AL- Series worm gearboxes
ALM- Series motorised worm gearboxes



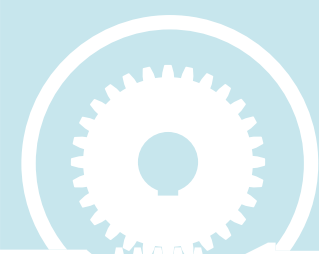

Premium 'AL' Series Gearboxes

Premium Energy Transmission provides most comprehensive range of gearboxes for over 40 years in India. Wide range of Power Transmission products offered by Premium enjoy the international reputation for quality and reliability. Over one million gears supplied by Premium are working to the entire satisfaction of our valued customers. Naturally customers keep coming back to us making Premium retain '**Leadership in Power Transmission**'.

Technical Characteristics :

Premium 'AL' series gearboxes are manufactured with high quality material and modern design in order to guarantee the maximum reliability and life.

Housing, flanges and feet are made out of aluminium alloy upto size 090 and for sizes 110 and above cast iron is used.

Wormshafts are made of steel and are case hardened to 58-60 HRC and profile ground.

The thread grinding in the gear ratios that the module value permits is carried out with ZI-Profile. This improves the contact between the toothed surfaces and therefore performance and reduces operating noise.

The wormwheel has a G20 cast iron hub onto which a casting in AB1 Bronze RIM is fitted.

To guarantee long life, ball bearings of reputed make used.

Lubrication of Gearboxes :

Gearboxes are supplied filled with synthetic oil grade ISO VG 320 which is virtually maintenance free and does not require oil change.

Measurement Units

- i = Ratio of the gear unit
- n_1 = Input speed (rpm)
- T_2' = Motor output torque (NM)
- T_c = Ambient temperature (°C)
- T_2 = Gear Box output torque (NM)

Output shafts

All worm gearboxes are supplied with hollow output shaft. Solid output shafts as shown in the drawings can be supplied upon request.

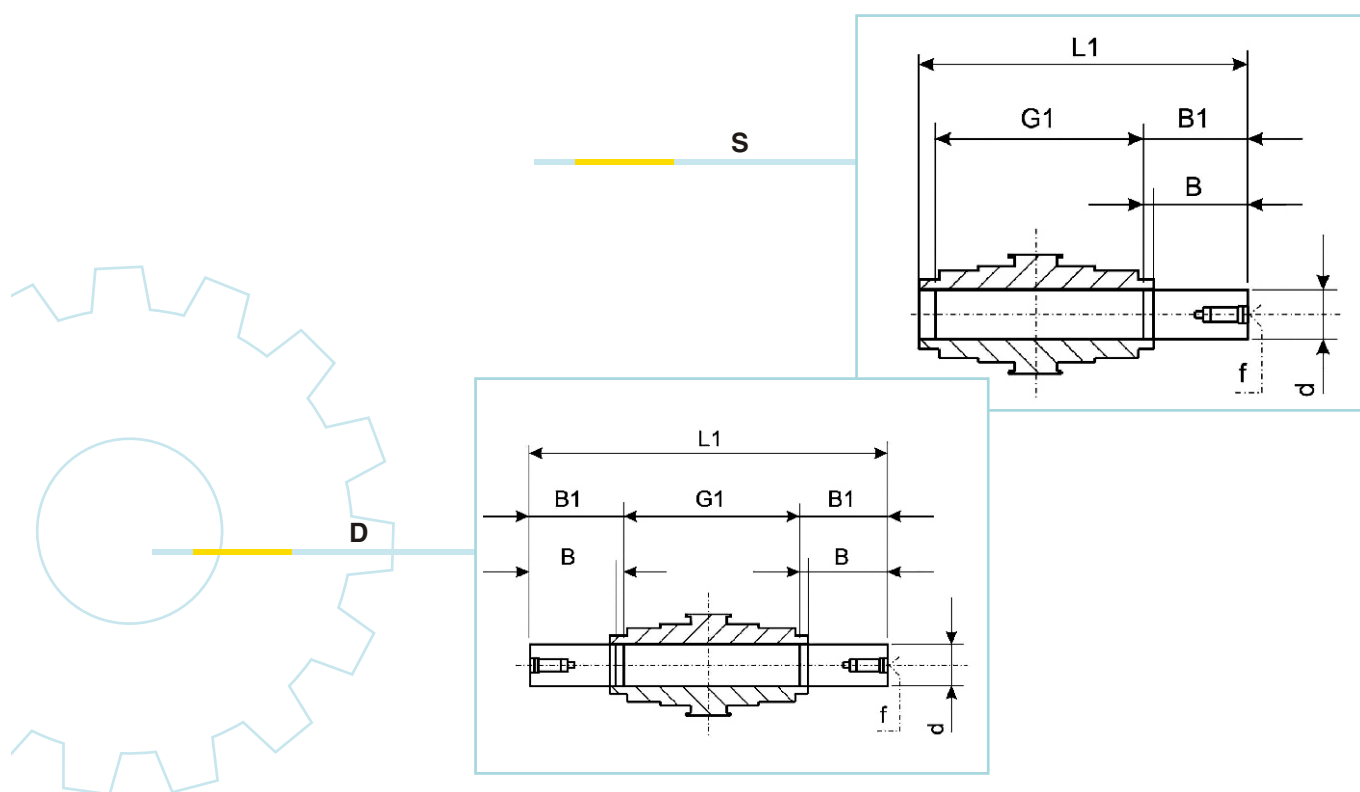

Size	dh6	B	B1	G1	L	L1	f	b1	t1
025	11	23	25.5	50	81	101	-	4	12.5
030	14	30	32.5	63	102	128	M6	5	16
040	18	40	43	78	128	164	M6	6	20.5
050	25	50	53.5	92	153	199	M10	8	28
063	25	50	53.5	112	173	219	M10	8	28
075	28	60	63.5	120	192	247	M10	8	31
090	35	80	84.5	140	234	309	M12	10	38
110	42	80	84.5	155	249	324	M16	12	45

Note: All output shaft are supplied in kit complete with keys, washers and screws (as well as snap

Qty of oil in litres									
ALM	025	030	040	050	063	075	090	110	130
B3.20								3.0	4.5
B3.21								2.2	3.3
B3.22-B3.23								2.5	3.5



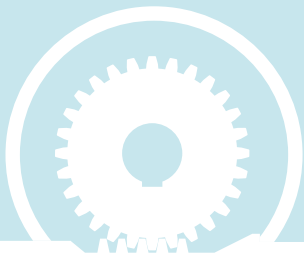

Premium 'AL' Series Gearboxes

Installation :

Install the gearbox and eliminate all vibrations. Take special care over alignment between the gear unit, the motor and the driven machine, fitting flexible or self-adjusting couplings wherever possible. When the gearbox is subject to prolonged overloads, shocks or possible jamming, fit thermostatic cut-outs, torque limiters, hydraulic couplings or other similar devices (take care not to exceed the permitted radial and axial loads on the input and output shafts). Ensure that the components to be assembled on the gearboxes are machined with tolerance SHAFT ISO h6/ HOLE ISO H7. Before assembling, clean and lubricate the surface to prevent jamming and contact oxidation. Assembly and disassembly should be made with care and possibly using the tapped hole in the end of the shaft which is provided for this purpose. When painting, protect the oilseals to prevent the paint from drying the rubber and impairing sealing properties.

Maintenance:

"Life" lubricated gearboxes do not require any maintenance as they are supplied with the correct quantity of synthetic oil. On gear units lubricated with mineral oil, after the first 500 -1000 operating hours change the oil, washing out the inside of the gear unit thoroughly. Synthetic lubricants are not compatible and hence should not be mixed with mineral lubricants.

Storage : In order to preserve and keep performances of the gearboxes unaltered, we suggest to follow these instructions:

- Do not store outdoors or in humid areas, protect the working parts (shafts, surfaces and flanges) with antioxidants.

Dimensions - Single Input Shaft

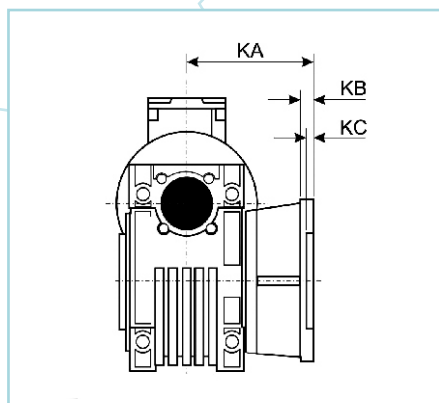
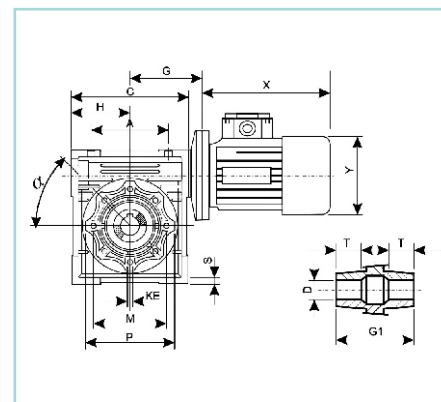
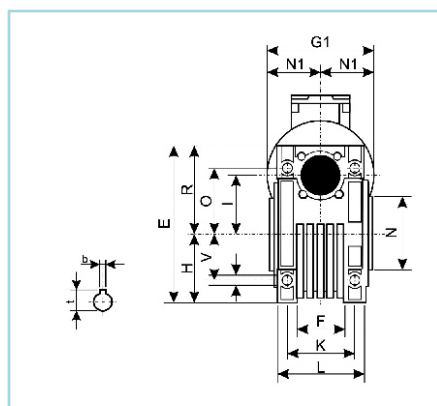
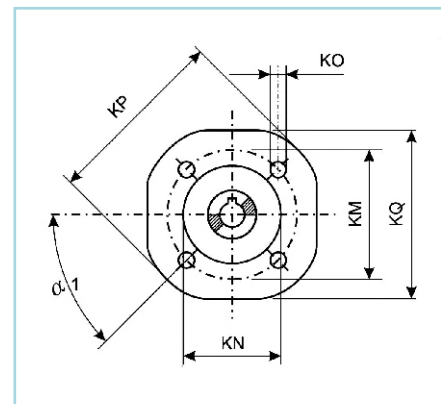
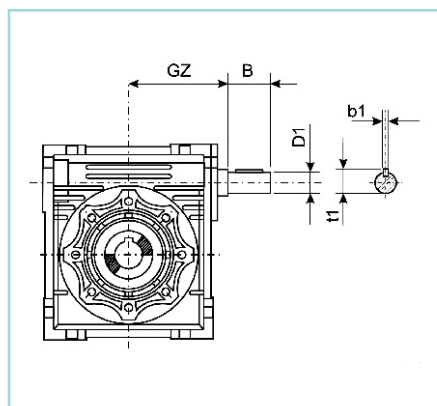

	A	B	C	D(H7)	D1(J6)	E	F	G	G1	G2	H	I	L	M	N(h8)	N1	O	P	Q	R
030	54	20	80	14	9	97	32	55	63	51	40	30	56	65	55	29	6.5	75	44	57
040	70	23	100	18(19)	11	121.5	43	70	78	60	50	40	71	75	60	36.5	6.5	87	55	71.5
050	80	30	120	25(24)	14	144	29	80	92	74	60	50	85	85	70	43.5	8.5	100	64	84
063	100	40	144	25(28)	19	174	67	95	112	90	72	63	103	95	80	53	8.5	110	80	1.2
075	120	50	172	28(35)	24	205	72	112.5	120	105	86	75	112	115	95	57	11	140	93	119
090	140	50	208	35(38)	24	238	74	129.5	140	125	103	90	130	130	115	67	3	160	102	135
110	170	60	252.5	42	28	295	-	160	155	142	127.5	110	144	165	130	74	14	200	125	167.5



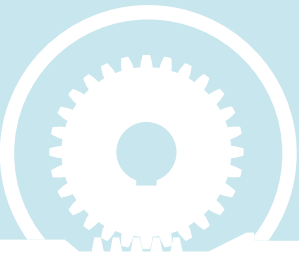

Premium 'AL' Series Gearbox Ratings - Input Speed (n1) 1500PM

Power	Model	i (Ratio)	n2 (output rpm)	T2 (NM) (output torque)
0.55kw	AL040	7.5	186	24.5
	AL050	7.5	18	25
	AL040	10	140	32
	AL050	10	140	32
	AL050	15	94	46
	AL063	15	94	46
	AL050	20	70	59
	AL063	20	70	60
	AL063	25	56	72
	AL063	30	47	80
	AL063	40	35	104
	AL075	40	35	108
	AL063	50	28	123
	AL075	50	28	129
	AL075	60	24	146
	AL075	80	18	180
AL075	100	14	180	
0.75kw	AL050	7.5	186	34
	AL063	7.5	186	33
	AL050	10	140	44
	AL063	10	140	44
	AL050	15	94	63
	AL063	15	94	63
	AL063	20	70	82
	AL063	25	56	99
	AL063	30	47	109
	AL075	30	47	116
	AL063	40	35	143
	AL075	40	35	147
	AL075	50	28	176
	AL090	50	28	184
	AL075	60	24	200
	AL090	60	24	212
AL090	80	18	257	
1.1kw	AL090	100	14	270
	AL063	7.5	186	49
	AL075	7.5	186	49
	AL063	10	140	65
	AL075	10	140	65
	AL063	15	94	93
	AL075	15	94	95
	AL063	20	70	121
	AL075	20	70	122
	AL075	25	56	149
	AL075	30	47	170
	AL075	40	35	216
	AL090	40	35	225
	AL090	50	28	271
	AL090	60	24	311
	AL110	60	24	324
AL110	80	18	410	
AL110	100	14	460	
1.5kw	AL075	7.5	186	67
	AL075	10	140	90
	AL063	15	94	130
	AL075	20	70	167
	AL075	25	56	200
	AL090	25	56	209
	AL075	30	47	230

Power	Model	i (Ratio)	n2 (output rpm)	T2 (NM) (output torque)
1.5kw	AL110	50	28	375
	AL110	60	24	442
	AL110	80	18	490
	AL130	80	18	547
	AL130	100	14	652
2.2kw	AL090	7.5	186	101
	AL110	7.5	186	101
	AL090	10	140	133
	AL110	10	140	133
	AL090	15	94	193
	AL110	15	94	192
	AL090	20	70	251
	AL110	20	70	256
	AL090	25	56	307
	AL110	25	56	316
	AL090	30	47	346
3.0kw	AL110	30	47	355
	AL110	40	35	462
	AL110	50	28	550
	AL130	50	28	567
	AL130	60	24	660
	AL130	80	18	803
	AL110	7.5	186	138
	AL110	10	140	182
	AL110	15	94	263
	AL110	20	70	350
	AL110	25	56	431
4.0kw	AL110	30	47	484
	AL110	40	35	631
	AL130	40	35	642
	AL130	50	28	773
	AL130	60	24	900
	AL110	7.5	186	184
	AL130	7.5	186	186
	AL110	10	140	243
	AL130	10	140	242
	AL110	15	94	352
	AL130	15	94	357
5.5kw	AL110	20	70	464
	AL130	20	70	466
	AL110	25	56	573
	AL130	25	56	572
	AL110	30	47	646
	AL130	30	47	655
	AL130	40	35	857
	AL130	50	28	980
	AL110	7.5	186	253
	AL130	7.5	186	256
	AL110	10	140	334
7.5kw	AL130	10	140	334
	AL110	15	94	484
	AL130	15	94	490
	AL130	20	70	645
	AL130	25	56	788
	AL130	30	47	900
	AL110	7.5	186	345
	AL130	7.5	186	349
	AL110	10	140	455
	AL130	10	140	455
AL130	15	94	667	

Dimensions " ALM" - MOTORISED

ALM

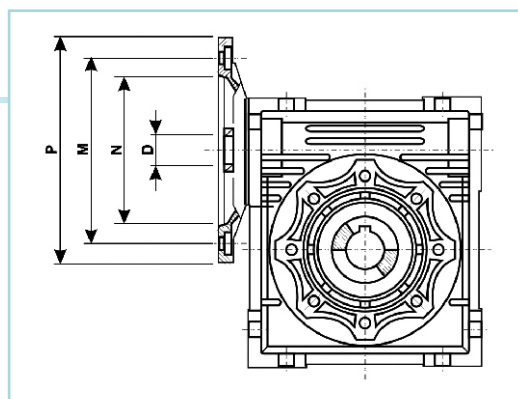

Model	PAM IEC	N	M	P	7.5	10	15	20	25	30	40	50	60	80	100
					D										
AL025	56B14	50	65	80											
	63B5	95	115	140											
AL030	63B14	60	75	90											
	56B5	80	100	120											
	56B14	50	65	80											
	71B5	110	130	160											
AL040	71B14	70	85	105											
	63B5	95	115	140											
	63B14	60	75	90											
	56B5	80	100	120											
AL050	80B5	130	165	200											
	80B1	480	100	120											
	71B5	110	130	160											
	71B14	70	85	105											
AL063	63B5	95	115	140											
	90B5	130	165	200											
	90B14	95	115	140											
	80B5	130	165	200											
	80B14	80	100	120											
AL075	71B5	110	130	160											
	71B14	70	85	105											
	100/112B5	180	215	250											
	100/112B14	110	130	160											
	90B5	130	165	200											
	90B14	95	115	140											
	80B5	130	165	200											
AL090	80B14	80	100	120											
	71B5	110	130	160											
	100/112B5	180	215	250											
	100/112B4	110	130	160											
	90B5	130	165	200											
AL0110	90B14	95	115	140											
	80B5	130	165	200											
	80B14	80	100	120	38	38	38	38	-	-	-	-	-	-	-
	132B5	230	265	300	28	28	28	28	28	28	28	28	28	-	-
AL0130	100/112B5	180	215	250	-	-	-	-	24	24	24	24	24	24	24
	90B5	130	165	200	-	-	-	-	-	-	-	-	-	19	19
	80B5	130	165	200	38	38	38	38	38	38	38	-	-	-	-
AL0130	80B5	130	165	200	38	38	38	38	38	38	38	-	-	-	-
	132B5	230	265	300	-	-	-	-	28	28	28	28	28	28	28

B5 - For standard TEFC Motor



Dimensions - Motorised

Size	A	B	C	D (H7)	D1 (J6)	E	F	G	G1	G2	H	I	L	M	N (h8)N	N1
030	54	20	80	14	9	97	32	55	63	51	40	30	56	65	55	29
040	70	23	100	18(19)	11	121.5	43	70	78	60	50	40	71	75	60	36.5
050	80	30	120	25(24)	14	144	29	80	92	74	60	50	85	85	70	43.5
063	100	40	144	25(28)	19	174	67	95	112	90	72	63	103	95	80	53
075	120	50	172	28(35)	24	205	72	112.5	120	105	86	75	112	115	95	57
090	140	50	208	35(38)	24	238	74	129.5	140	125	103	90	130	130	115	67
110	170	60	252.5	42	28	295	-	160	155	142	127.5	110	144	165	130	74

Size	O	P	Q	R	S	T	V	K	KA			KB		
									F	FB	FL	F	FB	FL
030	6.5	75	44	57	5.5	21	27	44	54.5	-	-	6	-	-
040	6.5	87	55	71.5	6.5	26	35	60	67	76.5	97	7	9	7
050	8.5	100	64	84	7	30	40	70	90	87.5	120	9	10	9
063	8.5	110	80	1.2	8	36	50	85	82	99	112	10	11	10
075	11	140	93	119	10	40	60	90	111	-	-	13	-	-
090	3	160	102	135	11	45	70	100	111	-	-	13	-	-
110	14	200	125	167.5	14	50	85	115	131	-	-	15	-	-

Size	KC			KE	a	a1	KM			KN(H8)		
	F	FB	FL				F	FB	FL	F	FB	FL
030	4	-	-	M6*11(n.4)	0°	45°	68	-	-	50	-	-
040	4	5	4	M6*8(n.4)	45°	45°	87	115	87	60	95	60
050	5	5	5	M8*10(n.4)	45°	45°	90	130	90	70	110	70
063	6	5	8	M8*14(n8)	45°	45°	150	165	150	115	130	11
075	6	-	-	M8*14(n8)	45°	45°	165	-	-	130	-	130
090	6	-	-	M10*18(n8)	45°	45°	175	-	-	152	-	152
110	6	-	-	M10*18(n8)	45°	45°	230	-	-	170	-	170

Size	KO			KP			KQ			b	b1	f	t	t1	kg
	F	FB	FL	F	FB	FL	F	FB	FL						
030	6.5(n.4)	-	-	80	-	-	70	-	-	5	3	-	16.3	10.2	1.2
040	9(n.4)	9.5(n.4)	9(n.4)	110	140	110	95	-	95	6(6)	4	-	20.8(21.8)	12.5	2.3
050	11(n.4)	9.5(n.4)	11(n.4)	125	160	120	110	-	110	8(8)	5	M6	28.3(27.3)	16.0	3.5
063	11(n.4)	11(n.4)	11(n.4)	180	200	180	142	-	142	8(8)	6	M6	28.3(31.3)	21.5	6.2
075	14(n.4)	-	-	200	-	-	170	-	-	8(10)	8	M8	31.3(38.3)	27.0	9
090	14(n.4)	-	-	210	-	-	200	-	-	10(10)	8	M8	38.3(41.3)	27.0	13
110	14(n.8)	-	-	280	-	-	260	-	-	12	8	M10	45.3	31.0	35

Premium 'AL' Series Gearbox Ratings - Input Speed (n1) 1500PM

Power	Model	i (Ratio)	n2 (output rpm)	T2 (NM) (output torque)
0.06kw*	AL025	7.5	186	2.6
	AL030	7.5	186	2.6
	AL025	10	140	3.4
	AL030	10	140	3.4
	AL025	15	94	4.9
	AL030	15	94	4.7
	AL025	20	70	6.1
	AL030	20	70	6
	AL030	25	56	7
	AL025	30	47	8.2
	AL030	30	47	8
	AL025	40	35	10.2
	AL030	40	35	9.7
	AL025	50	28	11
	AL030	50	28	11.3
	AL040	50	28	12.7
	AL025	60	24	11
	AL030	60	24	12.5
	AL040	60	24	14.2
	0.09kw*	AL030	80	18
AL040		80	18	17
AL040		100	14	19.2
AL025		7.5	186	3.9
AL030		7.5	186	3.9
AL025		10	140	5.1
AL030		10	140	5
AL025		15	94	7.3
AL030		15	94	7.1
AL025		20	70	9.2
AL030		20	70	9
AL030		25	56	10.4
AL025		30	47	12.3
AL030		30	47	12
AL025		40	35	13
AL030		40	35	14.5
AL030		50	28	16.9
AL040		50	28	19
AL030		60	24	16.9
AL040		60	24	21.4
AL040	80	18	25.5	
0.12kw	AL040	100	18	28.9
	AL030	7.5	186	5.2
	AL040	7.5	186	5.3
	AL030	10	140	6.7
	AL040	10	140	7
	AL030	15	94	9.5
	AL040	15	94	10.1
	AL030	20	70	12
	AL040	20	70	12.8
	AL030	25	56	13.9
	AL040	25	56	15.3
	AL030	30	47	16
	AL040	30	47	17.2
	AL030	40	35	17
	AL040	40	35	21.3
	AL050	40	35	21.9
	AL040	50	28	25.4

Power	Model	i (Ratio)	n2 (output rpm)	T2 (NM) (output torque)
0.12kw	AL050	60	24	29
	AL040	80	18	34.1
	AL050	80	18	34.7
	AL050	100	14	40.1
0.18kw	AL030	7.5	186	8
	AL040	7.5	186	8
	AL030	10	140	10
	AL040	10	140	10
	AL030	15	94	14
	AL040	15	94	15
	AL030	20	70	18
	AL040	20	70	19
	AL030	25	56	20
	AL040	25	56	23
	AL040	30	47	26
	AL040	40	35	32
	AL050	40	35	32
	AL040	50	28	38
	AL050	50	28	38
	AL050	60	24	34
AL050	80	18	53	
0.25kw	AL050	100	14	55
	AL040	7.5	186	11
	AL050	7.5	186	11
	AL040	10	140	14
	AL050	10	140	14
	AL040	15	94	20
	AL050	15	94	21
	AL040	20	70	26
	AL050	20	70	26
	AL040	25	56	31
	AL050	25	56	32
	AL040	30	47	36
	AL050	30	47	36
	AL040	40	35	44
	AL050	40	35	45
	AL050	50	28	53
AL050	60	24	60	
AL050	80	18	65	
AL063	80	18	77	
0.37kw	AL050	100	14	55
	AL063	100	14	85
	AL040	7.5	186	16
	AL050	7.5	186	16
	AL040	10	140	21
	AL050	10	140	21
	AL040	15	94	30
	AL050	15	94	31
	AL040	20	70	39
	AL050	20	70	39
	AL050	25	56	47
	AL050	30	47	54
	AL050	40	35	66
	AL063	40	35	70
	AL050	50	28	73
	AL063	50	28	83
AL063	60	24	95	

* supplied against specific request



Dimensions - Double Input Shaft

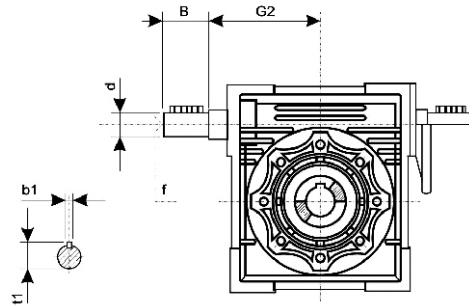

Size	G2	d (j6)	B	f	b1	t1
030	45	9	20	-	3	10.2
040	53	11	23	-	4	12.5
050	64	14	30	M6	5	16
063	75	19	40	M6	6	21.5
075	90	24	50	M8	8	27
090	108	24	50	M8	8	27
110	135	28	60	M10	8	31

Dimensions - Torque ARM

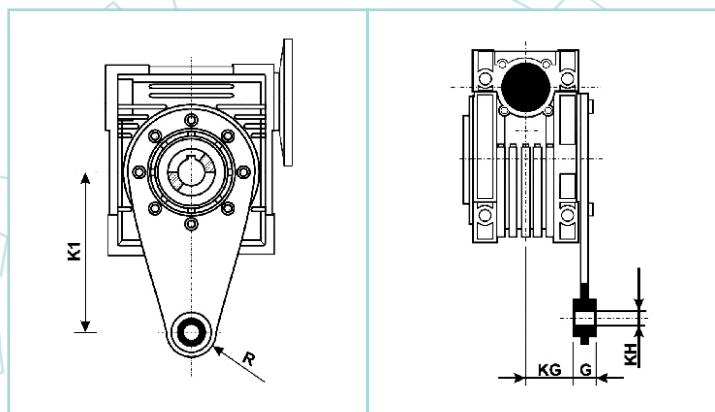

Size	K1	G	KG	KH	R
025	70	14	17.5	8	15
030	85	14	24	8	15
040	100	14	31.5	10	18
050	100	14	38.5	10	18
063	150	14	49	10	18
075	200	25	47.5	20	30
090	200	25	57.5	20	30
110	250	30	62	25	35

The anti-vibration bushing is not fitted on size 025 and 030.

Model & mark

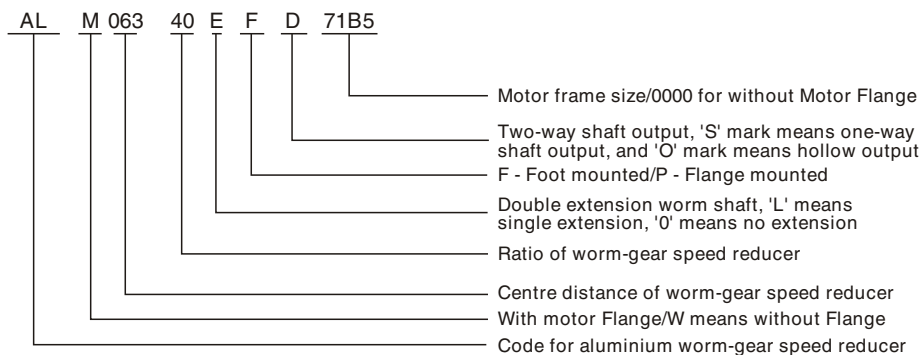

Premium 'AL' Series Gearbox Selection

Gearbox Selection :

In order to select the right gearbox, the torque T_2' required by the user and the output speed n_2 for a certain value of n_1 rpm must be taken into consideration. Given the values, select the corresponding gearbox referring to the tables of the gearbox performance where $T_2' \times FS$ is lower or equal to T_2 where FS is the application service factor.

Service factor :

The service factor FS permits approximate qualification of the type of application, taking into account the type of load, length of operation hr/d (hours/day) and the number of start-up/hour. The FS values reported in Table 1 refer to a drive unit with an electric motor. If a combustion engine is used, a multiplication factor of 1.5 must be

TABLE 1

SERVICE FACTOR (FS)										
PRIME MOVER	hr/d	UNIFORM LOAD					MODERATE SHOCK LOAD		HEAVY SHOCK LOAD	
		No. of start-up per hr.					No. of start-up per hr.		No. of start-up per hr.	
		4	16	32	125	500	16	500	16	500
HYDRAULIC / ELECTRIC MOTOR	4	0.8	0.9	1.0	1.1	1.2	1.0	1.3	1.3	1.5
	8	1.0	1.1	1.3	1.3	1.3	1.3	1.5	1.5	1.8
	16	1.3	1.3	1.5	1.5	1.5	1.5	1.8	1.8	2.2



GREAVES GEARS

Leadership in Power Transmission



PREMIUM

Premium Energy Transmission Limited

Head Office : P.B. No. 5, Chinchwad, Pune - 411 019, India.
Tel. : (91-20) 27475141/42/43/44, Fax : (91-20) 27450287, 27476601.
Website : www.premiumtransmission.com

Branch Offices :

Western Region :

Mumbai : Industry Manor, Appasaheb Marathe Marg, Prabhadevi, Mumbai - 400 025.

Tel. : (91-22) 24223747, 24365510, Fax : (91-22) 24377730.

Ahmedabad : "Jaldarshan", Ashram Road, Navrangpura, Ahmedabad - 380 009.

Tel. : (91-79) 26580428/0518/1861, Fax : (91-79) 26587783.

Nagpur : "Guman", Pandit Jawaharlal Nehru Marg, Sadar, P. B. No. 129, Nagpur - 440 001.

Tel. : (91-712) 2526588, 2524125, 2526038, Fax : (91-712) 2541142.

Northern Region :

New Delhi : Express Building Annexe, 9-10, Bahadur Shah Zafar Marg, New Delhi - 110 002.

Tel. : (91-11) 23730554 (8 lines), Fax : (91-11) 23359782.

Eastern Region :

Kolkata : Thapar House, 25, Brabourne Road, P. B. No. 702, Kolkata - 700 001.

Tel. : (91-33) 22423811, 22423780, 22423805, Fax : (91-33) 22424325.

Ranchi : Rani Kuthi, 82, Burdwan Compound, P.B. No. 139, Ranchi - 834 001.

Tel. : (91-651) 2562651, Fax : (91-651) 2562027.

Southern Region :

Chennai : 26, Second Line Beach, P. B. No. 207, Chennai - 600 001.

Tel. : (91-44) 25231120, Fax : (91-44) 25224557.

Bangalore : 16/3, Ali Asker Road, P. B. No. 216, Bangalore - 560 052.

Tel. : (91-80) 22268773/2506, Fax : (91-80) 22253472.

Hyderabad : 6-2-47, A. C. Guards, 1st floor, P. B. No. 9, Hyderabad - 500 004.

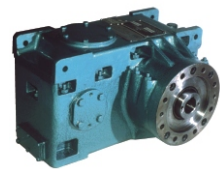

Premium Range of Power Transmission Products



PREMIUM

Premium Energy Transmission Limited

Mumbai - Pune Road, Chinchwad,
Pune 411 019, India
Ph. : (91-20) 27475141 / 42, Fax : 27450287
Website : <http://www.premiumtransmission.com>

WESTERN REGION :

Industry Manor,
Appasaheb Marathe Marg, Prabhadevi,
MUMBAI-400 025.
Ph. : (91-22) 24223747, 24365510
Fax : (91-22) 24377730 / 24379555

'Jaldarshan' Ashram Road, Navrangpura,
AHMEDABAD-380 009.
Ph. : (91-79) 26580428, 26580518, 26581861
Fax : (91-79) 26587783

'Guman' Pandit Jawaharlal Nehru Marg, Sadar, P.B. No. 129,
NAGPUR-440 001.
Ph. : (91-712) 2526588, 2524125, 2526038
Fax : (91-712) 2541142

NORTHERN REGION :

Express Building Annexe, 9-10,
Bahadur Shah Zafar Marg, **NEW DELHI-110 002.**
Ph. : (91-11) 23730554 (8 Lines)
Fax : (91-11) 23359782

EASTERN REGION :

Thapar House, 25 Brabourne Road,
P.B. No. 702, **KOLKATA-700 001.**
Ph. : (91-33) 22423811, 22423780, 22423805
Fax : (91-33) 22424325

Rani Kuthi, 82, Burdwan Compound,
P.B. NO. 139, **RANCHI-834 001.**
Ph. : (91-651) 2562651 Fax : (91-651) 2562027

SOUTHERN REGION :

26, Second Line Beach, P.B. No. 207,
CHENNAI-600 001.
Ph. : (91-44) 25231120 Fax : (91-44) 25224557

16/3, Ali Asker Road, P.B. No. 216, **BANGALORE-560 052.**
Ph. : (91-80) 22268773 / 22262506 Fax : (91-80) 22253472

39/5567, M.G. Road, Ernakulam, **KOCHI-682 015.**
Ph. : (91-484) 2359190, 2359372 Fax : (91-484) 2359589

6-2-47, A.C. Guards, 1st Floor, P.B. No. 9,
HYDERABAD-500 004.
Ph. : (91-40) 23314025, 23390544, 23316446
Fax : (91-40) 23318557



Geared Motor



Helical Gearbox



Altra



Extruder Gearbox



Worm Gearbox



Windmill Gearbox

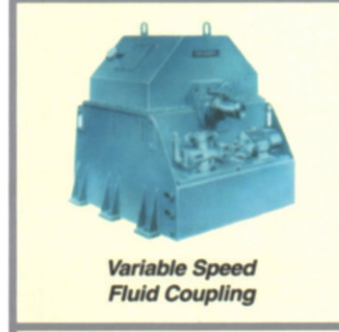

Variable Speed
Fluid Coupling



Cooling Tower Gearbox

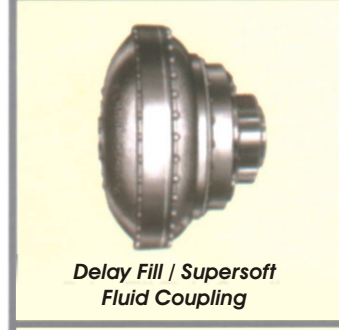

Delay Fill / Supersoft
Fluid Coupling



Aerator Gearbox



Traxol



Coal Pulverising
Mill Gearbox



PREMIUM

GREAVES PRODUCTS

(Click the product name to go to the file directly)

WORM

HELICAL

ABM SERIES

AERATOR DRIVE

PLANETARY

GEARED MOTORS

BEVEL CT

FLUID COUPLINGS

EXTRUDER

FLEXIBLE COUPLINGS

BEVEL B1

GEARED COUPLINGS

EC VARIABLE SPEED DRIVE